



**VIBIA**<sup>®</sup>  
ILUMINACIÓN CON SENTIDO

What you are holding is more than just a new catalogue.  
Slowly, as you turn the pages, you can see each and every  
one of the Vibia lamps. Top designers have accepted  
the challenge of participating in this thrilling adventure  
to design the future of lighting.  
Take part in the dawn of a new era in illumination.  
**VIBIA.**

En sus manos tiene mucho más que un nuevo catálogo.  
Descubra lentamente, página a página, todas y cada  
una de las lámparas Vibia. Los mejores diseñadores  
han aceptado el reto de participar en esta apasionada  
aventura de dibujar el futuro de la luz.  
Asista al estreno de una nueva era de la iluminación.  
**VIBIA.**

<b>Floor lamps</b>	
<b>Pies</b>	<b>7</b>
Aina	38/40
Balance	28
Code	15
Duplo	52
Forest	22
Funnel	32/34/37
Gigantic	54
Jazz	19
Kaos	50
Lollipop	42
Mast	58
Nadia	49
Nature	24
Plis	26
Samurai	69
Shell	60
Sigma	13
Swing	62/66
Te	46

<b>Table lamps</b>	
<b>Sobremesas</b>	<b>73</b>
Aina	112
Code	130
Diva	104
Forest	91
Jazz	81/85/89
Join	92
Kaos	102
Lollipop	120
Mast	118
Nadia	125
Nature	79
Plis	99
Spaghetti	110
Sumo	128
Swing	114/116
Test	96
Tulip	106

<b>Hanging lamps</b>	
<b>Colgantes</b>	<b>133</b>
Code	139
Corner	208/210
Duplo	160
Eight	172/174/177
Even	206
Forest	158
Glenn	194
Infinity	140
Iso	170
Jazz	186/188/190
Join	192
Kaos	180
Lollipop	198
Lotto	178
Mast	168
Moving	162/164
Nadia	184
Nature	157
Nobel	183
Plis	153
Puzzle	200
Sixties	196
Slim	144/148
Slim	150
Tulip	166

<b>Ceiling lamps</b>	
<b>Plafones</b>	<b>213</b>
Basik	273/275
Big	224
Chef	247
Corner	277/278
Funnel	218/222
Glamour	227
Lotto	269
Mini Quadra	256
Mini Top	265
Mini Top Glass	266
Quadra Ice	253
Quadra Ice Flat	259
Quadra Marc	260
Round Ice Flat	271
Sandwich	243/245
Tecto	231/235/237/239
Watch	249

<b>Downlight</b>	
<b>Empotrables</b>	<b>281</b>
Basik	290/292
Corner	284/286/288
Mini Marc	296
Mini Quadra	297
Sixties	294

<b>Spots</b>	<b>299</b>
Corner	302/304
Sixties	323/325/326/329
Soft	314/318/320
Stage	308/310

<b>Picture light</b>	
<b>Iluminacuadros</b>	<b>331</b>
Barcel'art	343
Da Vinci	340
Flauta	338
Gugen'art	335

<b>Bath lamps</b>	
<b>Baño</b>	<b>345</b>
Linestra	358
Llisa	354/357
Look	351/353
Millenium	349

<b>Wall lamps</b>	
<b>Apliques</b>	<b>361</b>
Aina	426
Arms Biluz	438
Basik	417
Corner	364/365
Cross	420
Diva	434/436
Funnel	370/375
Lollipop	430
Mini Quadra	390
Mini Sandwich	395
Mini Sandwich Glass	397
Mini Top	403
Ona	412
Pad	378
Quadra Ice	390
Scotch	404/406
Shell	419
Signal	399
Sinuosa	414
Slim	432
Soho	400
Swing	440/444
Tatiana	428
Te	410/425
Tecto	383/384/386/388
Tulip	422
Watch	393
Zero	408

<b>Garden</b>	
<b>jardin</b>	<b>447</b>
Tree	452/456

<b>Index referencias</b>	
<b>Item Index</b>	<b>462</b>

# Floor Lamps

## Pies

Aina	38/40
Balance	28
Code	15
Duplo	52
Forest	22
Funnel	32/34/37
Gigantic	54
Jazz	19
Kaos	50
Lollipop	42
Mast	58
Nadia	49
Nature	24
Plis	26
Samurai	69
Shell	60
Sigma	13
Swing	62/66
Te	46



FLOOR LAMPS  
PIES

0550-03.



0550-04.

**Sigma**  
 Design by Lievore, Altherr, Molina.

**0550.**  
 White lacquer or black lacquer /  
 Lacado blanco, lacado negro.  
 Methacrylate diffuser /  
 Difusor de metacrilato.  
 2 x 2G11 24W Max.

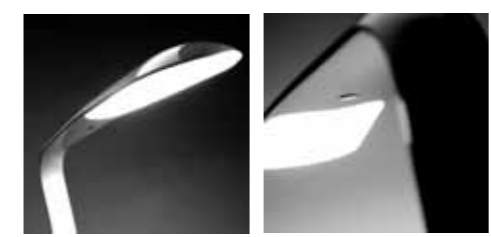
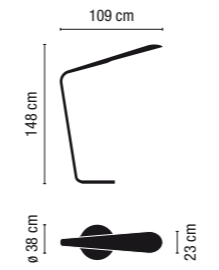

Dimmer / Regulador de intensidad.

**0550-03.** White lacquer / Lacado blanco. **0550-04.** Black lacquer / Lacado negro.

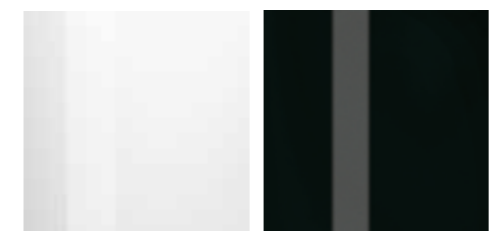

FLOOR LAMPS  
 PIES



0550-03.



2100-03.

FLOOR LAMPS  
PIES

**Code**  
Design by Diego Fortunato.

**2100.**  
White lacquer or black lacquer /  
Lacado blanco y lacado negro.  
Triplex blown-glass diffuser /  
Difusor de vidrio soplado triplex.  
4 x E14 Mate 230V 60W Max.

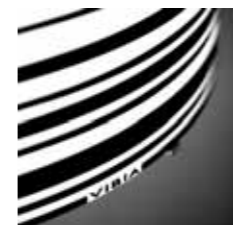
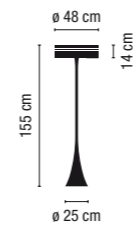

**2100-03.**  
White lacquer /  
Lacado blanco.



**2100-04.**  
Black lacquer /  
Lacado negro.



Switch on the cable / Interruptor en el cable.

2100-03.

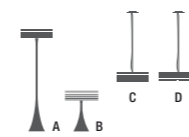

CODE. Family / Familia  
Pages / Páginas: A-14. B-86. C-86. D-134.

FLOOR LAMPS  
PIES



1330-03.





1330-03.



1330-04.



1330-06.



Dimmer on the cable /  
Con regulador de intensidad en el cable.



**Jazz**  
Design by Diego Fortunato.

**1330.**  
White lacquer, black lacquer, red lacquer,  
gold finish or silver finish /  
Lacado blanco, lacado negro, lacado rojo, acabado oro  
y acabado plata.  
Rigid high-density resin / Resina rígida alta densidad.  
R7s 117mm. 230V 500W Max.



**1330-03.** White lacquer / Lacado blanco. **1330-04.** Black lacquer / Lacado negro. **1330-06.** Red lacquer / Lacado rojo.

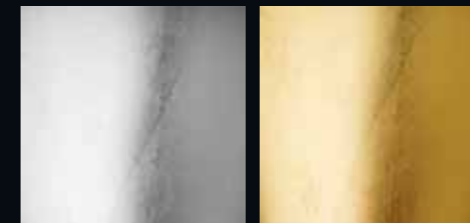
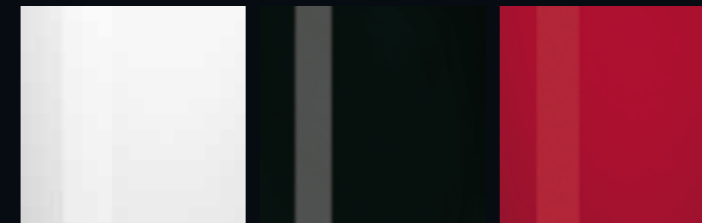

**1330-49.** Silver finish / Acabado plata. **1330-51.** Gold finish / Acabado oro.





1330-49.



1330-51.

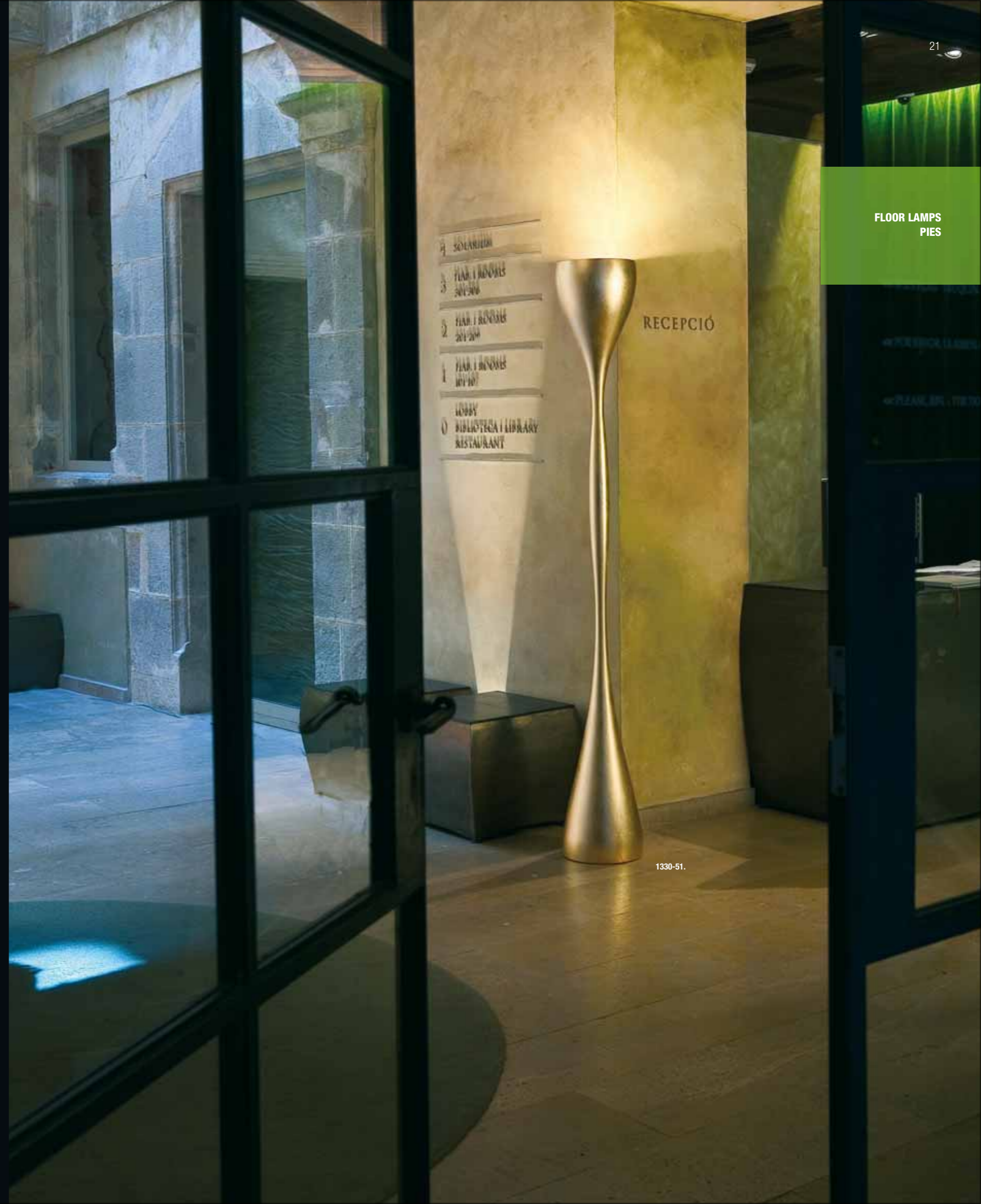

1330-51.

FLOOR LAMPS  
PIES

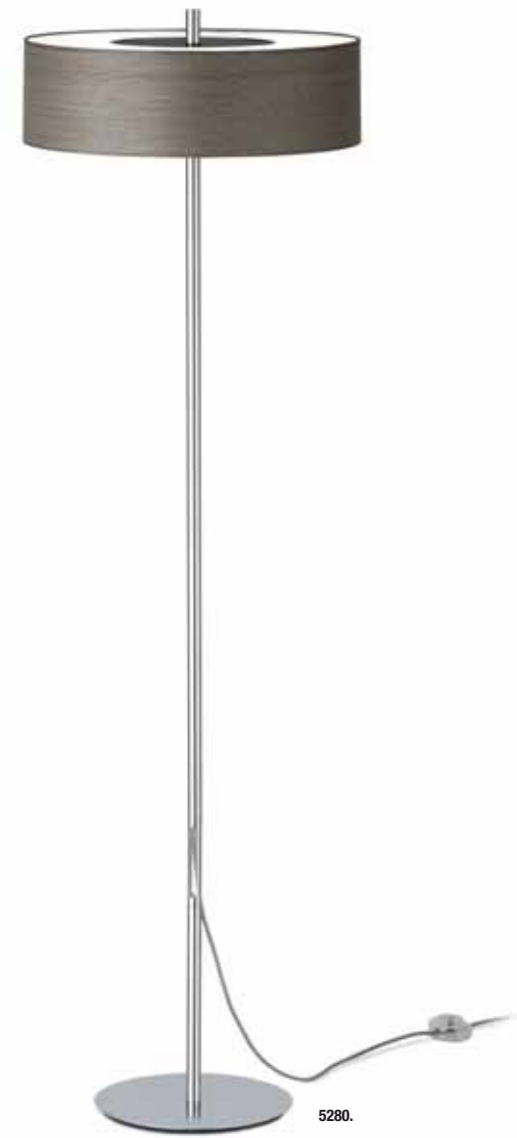

5280.

**Forest**  
Design by Ramos & Bassols.

**5280.**  
Chrome / Cromo.  
Wengue wood diffuser / Difusor madera wengué.  
4 x E14 Esférica Mate 60W Max.  
💡

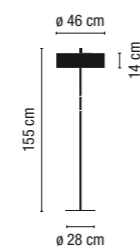

Black-glass disc /  
Disco de vidrio negro.



Optical glass on top  
and white methacrylate disc  
on the bottom /  
Vidrio óptico superior y disco  
metacrilato blanco inferior.



Switch on the cable /  
Interruptor en el cable.

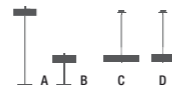

FOREST. Family / Familia  
Pages / Páginas: A-22. B-91. C-158. D-158.

FLOOR LAMPS  
PIES

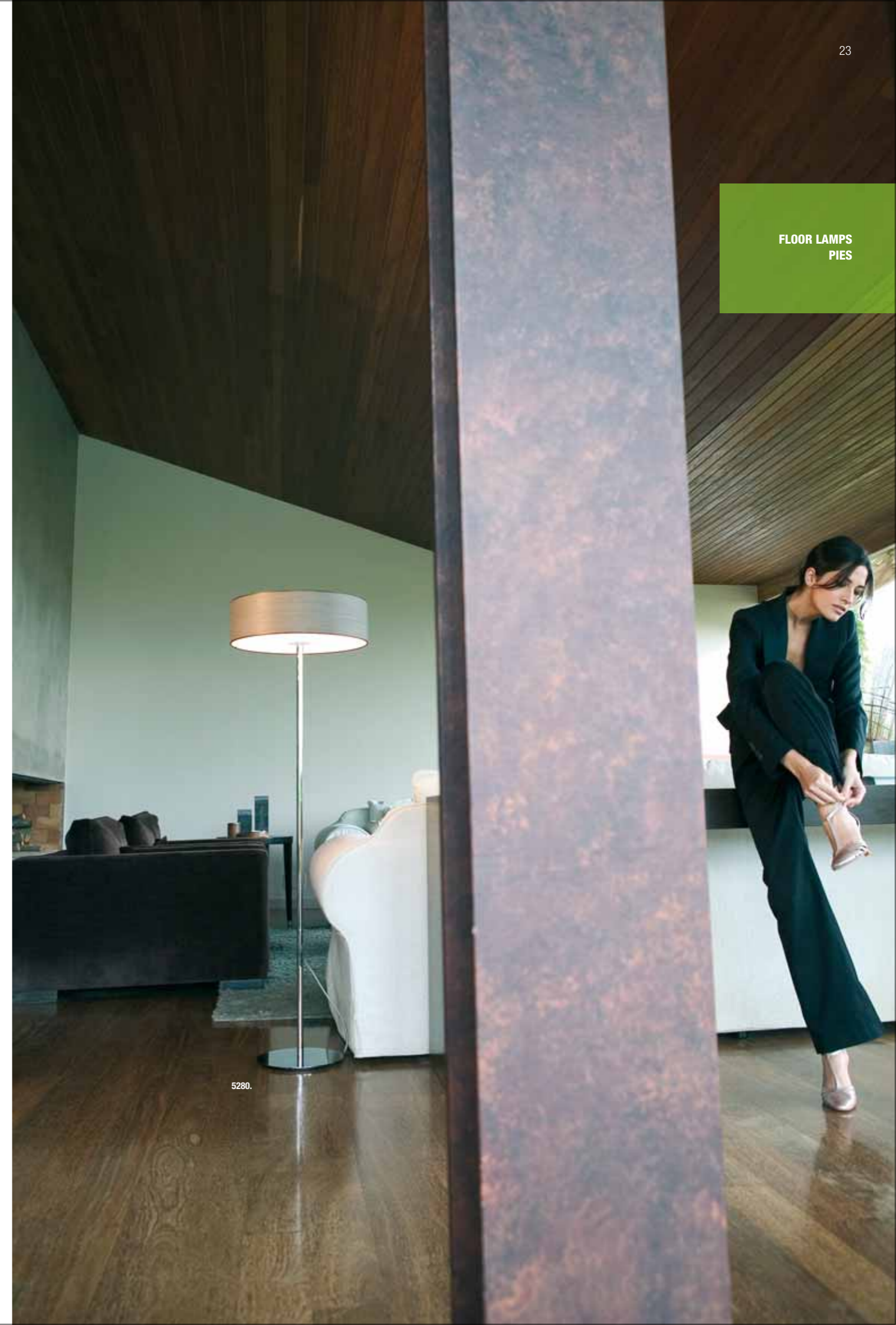

5280.



**Nature**  
Design by Diego Fortunato.

**1375.**  
White lacquer, black lacquer and matt nickel /  
Lacado blanco, lacado negro y Niquel mate.  
Metal diffuser / Difusor metálico.  
4 x E14 Estérica Mate 60W Max.

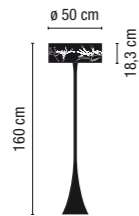

**1375-03.** White lacquer / Lacado blanco. **1375-04.** Black lacquer / Lacado negro. **1375-30.** Matt nickel / Niquel mate.



1375-04.

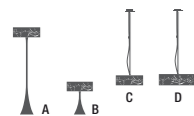

NATURE. Family / Familia  
Pages / Páginas: A-24. B-79. C-157. D-157.



1375-04.

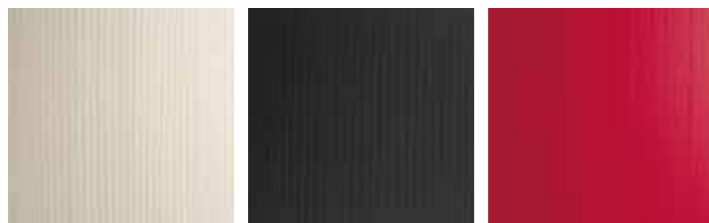

**5120.** Cream cotton ribbon diffuser / Difusor de cinta de algodón color crudo.  
**5121.** Black cotton ribbon diffuser / Difusor de cinta de algodón negro.  
**5122.** Red cotton ribbon diffuser / Difusor de cinta de algodón roja.

**Plis**  
 Design by G. Bernal & Associats.

**5120 / 5121 / 5122.**

Chrome / Cromo.  
**5120:** Cream cotton ribbon diffuser / Difusor de cinta de algodón color crudo.  
**5121:** Black cotton ribbon diffuser / Difusor de cinta de algodón negro.  
**5122:** Red cotton ribbon diffuser / Difusor de cinta de algodón rojo.  
 2 x E27 Mate 100W Max.

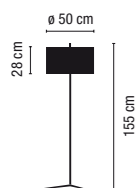

Pull switch. Four positions / Interruptor con tirador. Cuatro posiciones.  
 Methacrylate upper plate / Disco superior de metacri-lato.

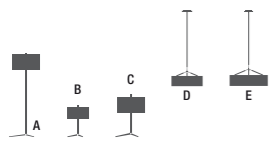

PLIS. Family / Familia  
 Pages / Páginas: A-26. B-99. C-99. D-152. E-152.

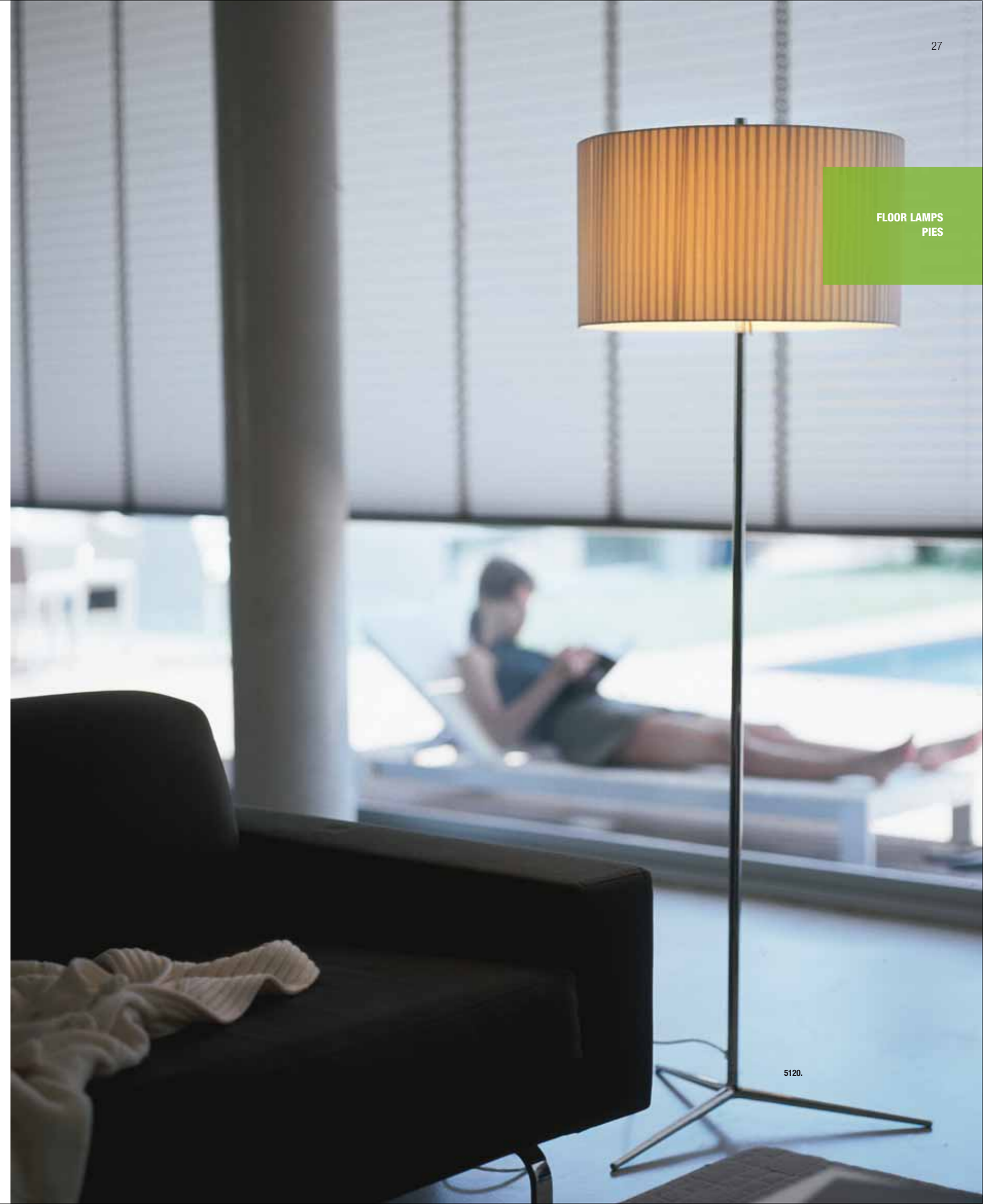
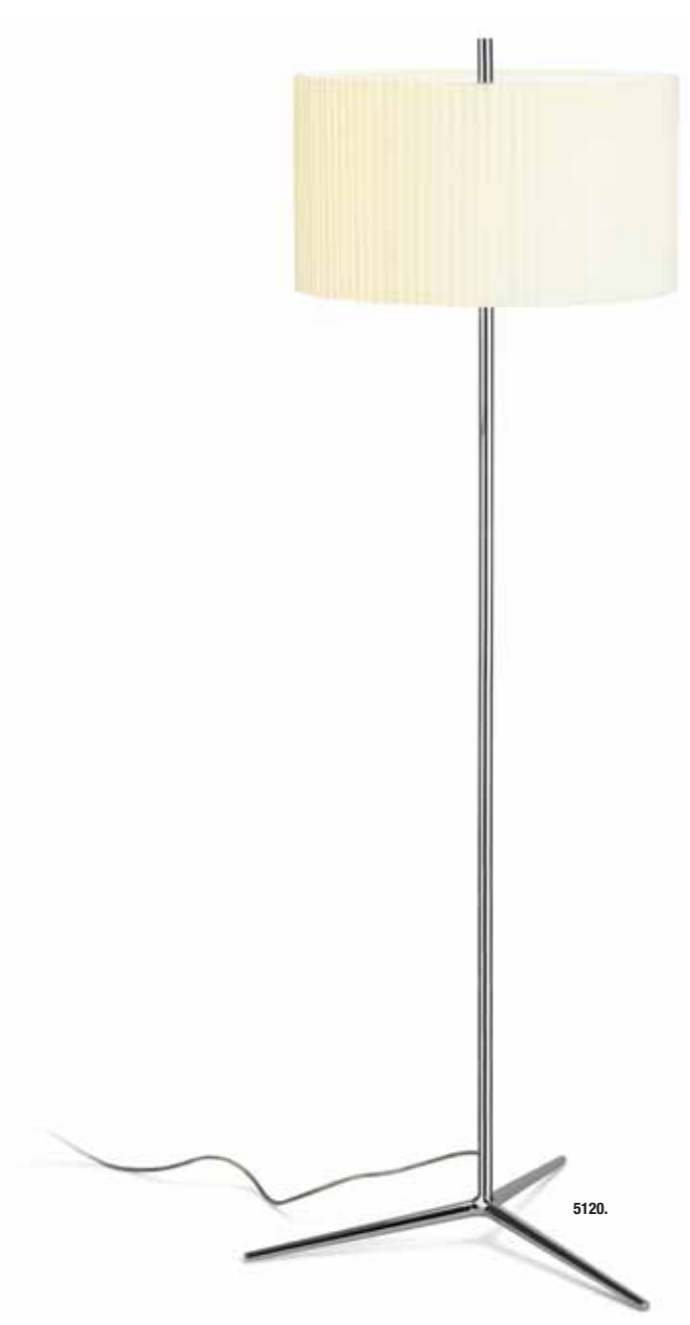

FLOOR LAMPS  
 PIES

5120.



5190-01.

NEW CHROME FINISH /  
NUEVO ACABADO CROMO

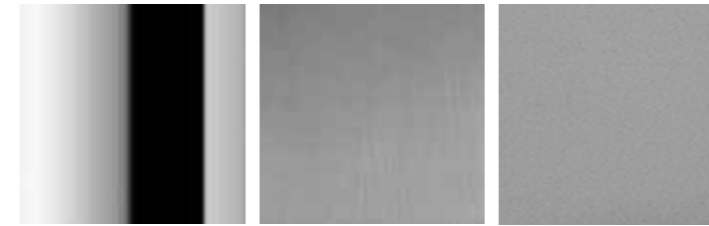

Chrome / Cromo. Matt nickel / Níquel mate. Metallic silver / Pintado plata.



5190 / 5191. Fabric diffuser / Difusor de algodón.



5189 / 5192. Metal weft diffuser / Difusor de trama metálica.

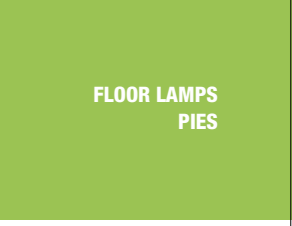

**Balance**  
Design by Jordi Vilardell.

**5190 / 5191 / 5189 / 5192.**  
Chrome, matt nickel or metallic silver / Cromo, níquel mate o pintado plata.  
**5190 / 5191.** Fabric diffuser / Difusor de algodón.  
**5189 / 5192.** Metal-weft diffuser / Difusor de trama metálica.  
3 x E27 100W Max.

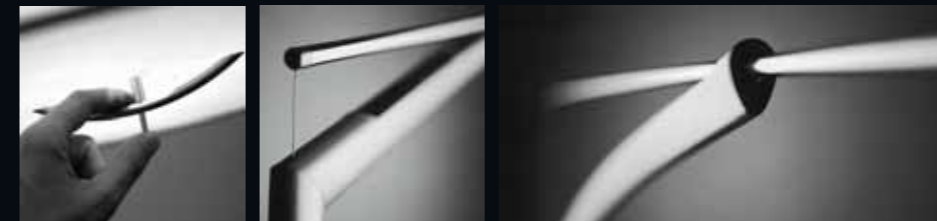
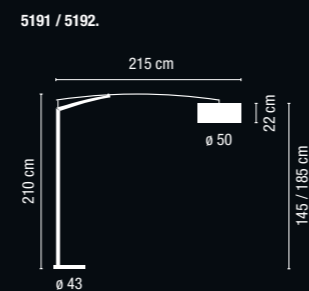
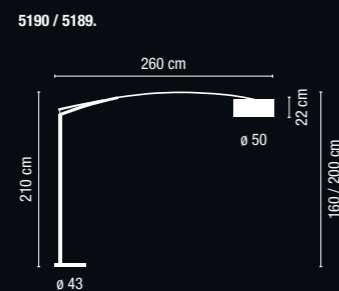

Switch on the bottom of the diffuser / Interruptor en la parte inferior de la pantalla.

Adjustable height / Altura regulable.

FLOOR LAMPS  
PIES



5190 -30.

### Funnel

**1996.**  
White lacquer, black lacquer or chrome /  
Lacado blanco, lacado negro o cromo.  
Aluminum diffuser / Difusor de aluminio.  
R7s 117mm. 230V 500W Max.

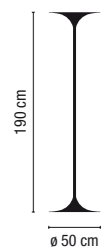

**1996-03.** White lacquer / Lacado blanco. **1996-04.** Black lacquer / Lacado negro. **1996-01.** Chrome / Cromo.

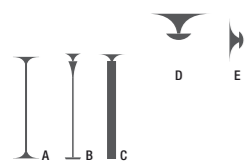

FUNNEL. Family / Familia  
Pages / Páginas: A-32. B-34. C-37. D-218/222. E-370/375.

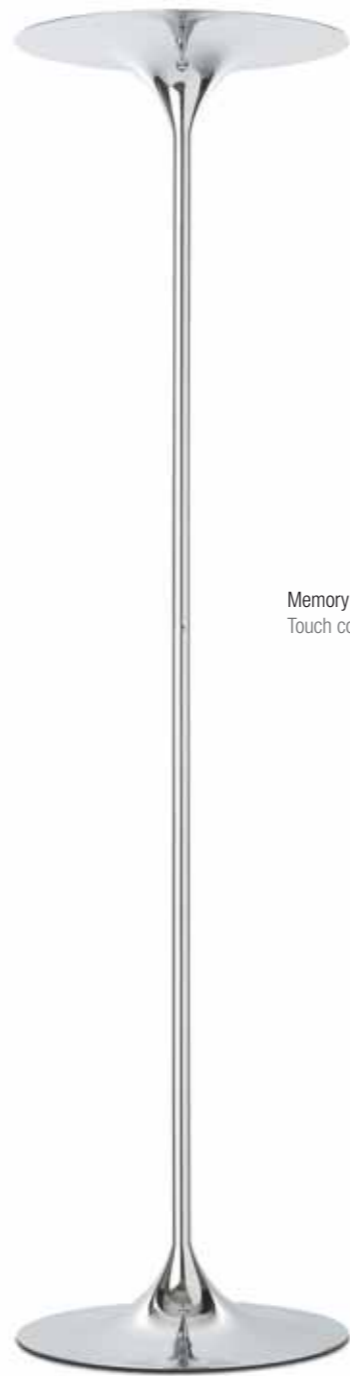

Memory touch /  
Touch con memoria.

1996-01.

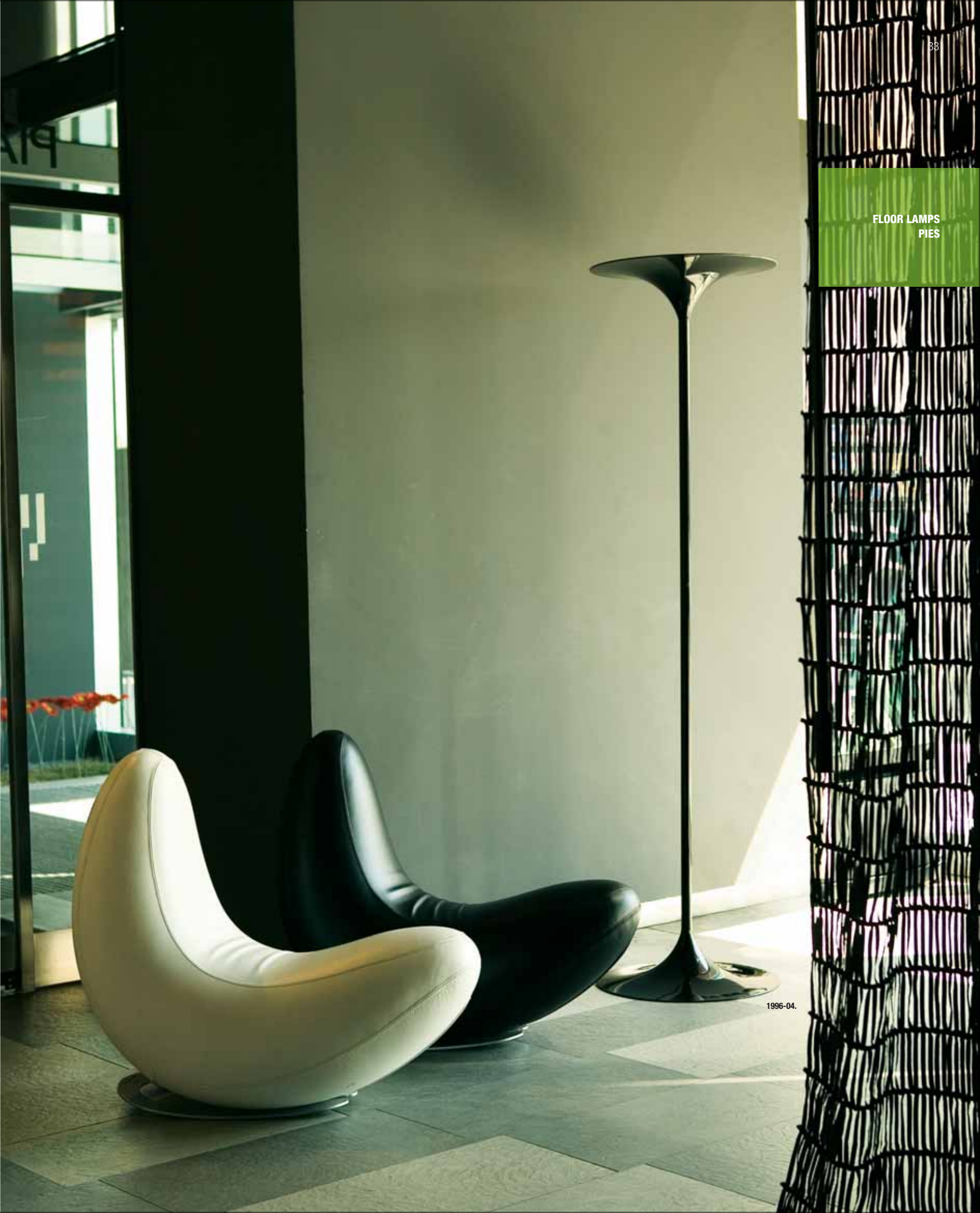

1996-04.

FLOOR LAMPS  
PIES





1997-03.

**Funnel**  
Design by Ramón Benedito.

**1997 / 1998.**  
**1997:** White lacquer or silver lacquer /  
Lacado blanco y lacado plata.  
**1998:** Matt nickel / Niquel mate.  
Aluminium diffuser / Difusor de aluminio.  
2x R7s 80mm. 230V 150W Max.  
1x R7s 117mm. 230V 300W Max.



Double memory touch / Doble touch con memoria.



FUNNEL. Family / Familia  
Pages / Páginas: A-32. B-34. C-37. D-218/222. E-370/375.

FLOOR LAMPS  
PIES

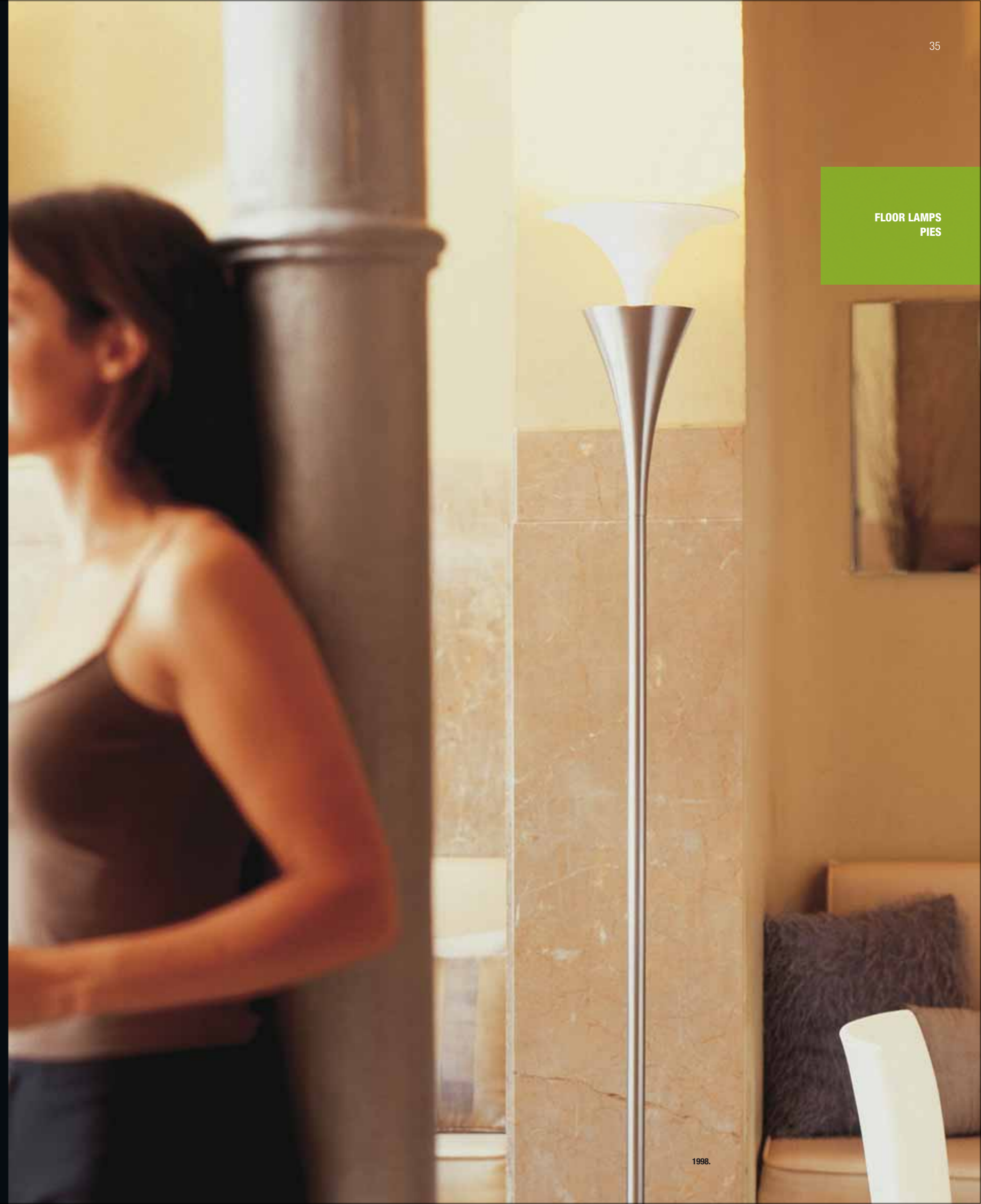

1998.



1999.

FLOOR LAMPS  
PIES

**Funnel**  
Design by Ramón Benedito.

**1999.**  
Stainless steel / Acero inoxidable.  
Aluminium diffuser / Difusor de aluminio.  
2x R7s 80mm. 230V 250W Max, R7s 117mm. 230V 500W Max.

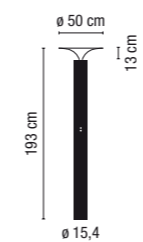

Double memory touch /  
Doble touch con memoria.



White - lacquered  
aluminium diffuser /  
Difusor de aluminio lacado  
blanco.



1999.

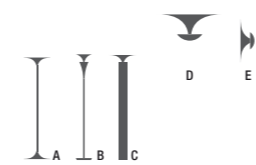

FUNNEL. Family / Familia  
Pages / Páginas: A-32. B-34. C-37. D-218/222. E-370/375.

**Aina**  
Design by Jordi Vilardell.

**5140.**  
Matt nickel / Níquel mate.  
Porcelain diffuser / Difusor de porcelana.  
2 x GU10 230V 50W Max.  
R7s 117mm. 230V 200W Max.

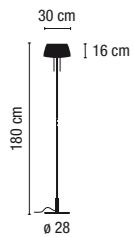

Memory touch for the upward indirect light. Individual switch for each spotlight / Touch con memoria para luz indirecta hacia arriba. Interruptor individual para cada foco.



Porcelain / Porcelana. Adjustable / Orientable.

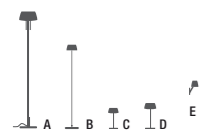

AINA. Family / Familia  
Pages / Páginas: A-38. B-40. C-112. D-112. E-426.



5140 -30.

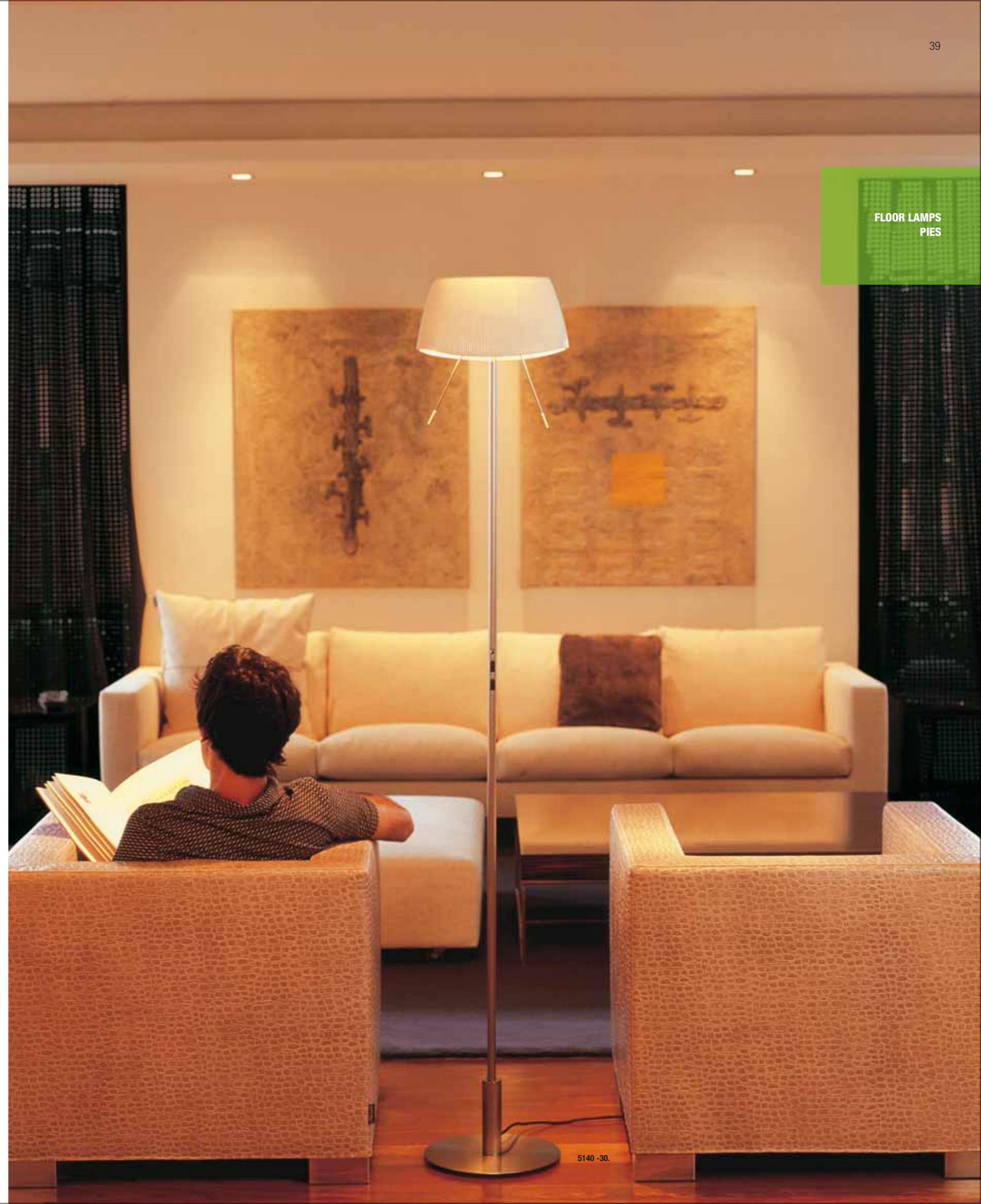

FLOOR LAMPS  
PIES

5140 -30.

**Aina**  
Design by Jordi Vilardell.

**5139.**  
Matt nickel / Níquel mate.  
Porcelain diffuser / Difusor de porcelana.  
2 x G9 230V 75W Max. (OSRAM HALOPIN).

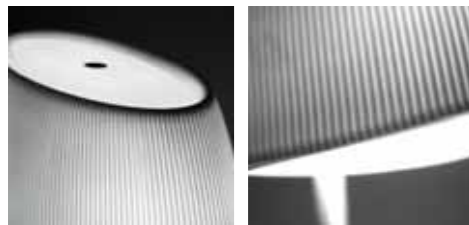
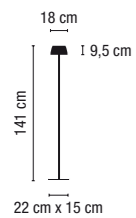

Porcelain diffuser. Glass on the top / Difusor de porcelana. Vidrio en la parte superior.

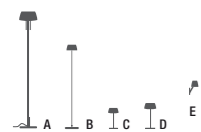

AINA. Family / Familia  
Pages / Páginas: A-38. B-40. C-112. D-112. E-426.

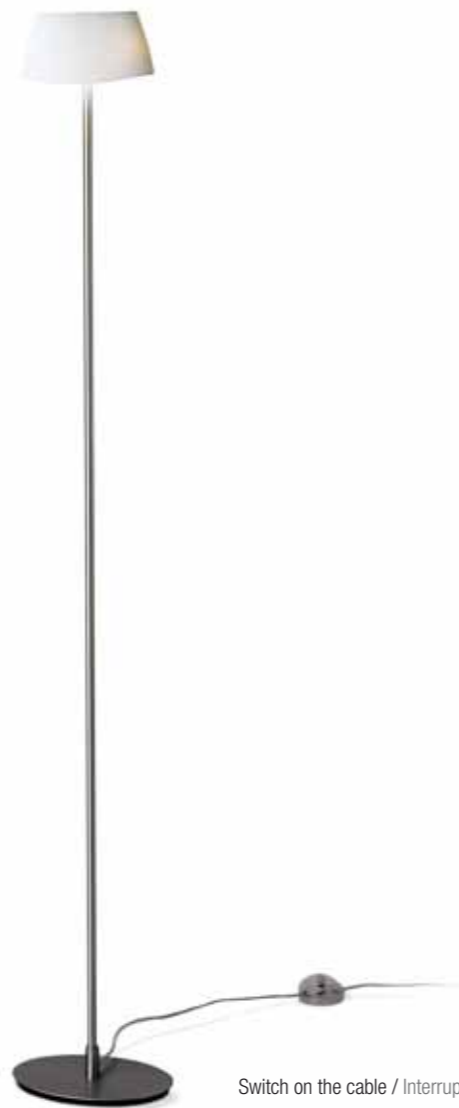

Switch on the cable / Interruptor en el cable.  
5139 -30.

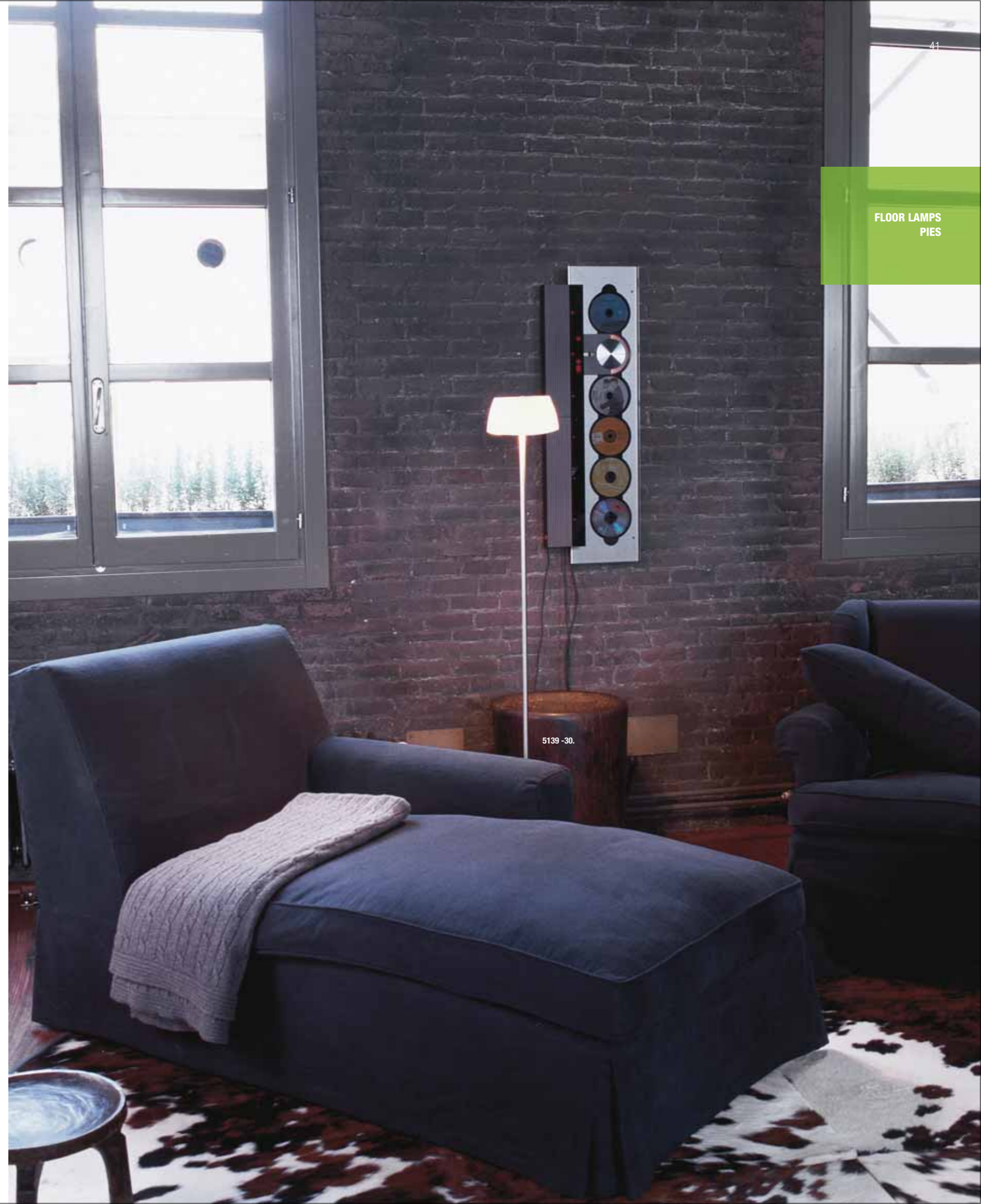

FLOOR LAMPS  
PIES

5139 -30.

**Lollipop**  
Design by Hopf & Wortman, Büro für form.

**0682 / 0683.**  
**0682:** Chrome and white lacquer / Lacado blanco y cromo.  
**0683:** Chrome and black lacquer / Lacado negro y cromo.  
 Borosilicate diffuser / Difusor de vidrio de borosilicato.  
 R7s 80mm. 230V 60W Max.

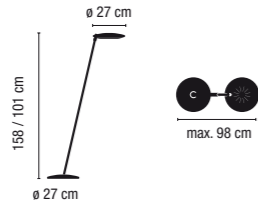

Dimmer on the cable /  
Con regulador de intensidad en el cable; tubo telescópico.

0682.

FLOOR LAMPS  
PIES



The base articulation (A) allows any position. Also the lamp head is completely adjustable (B), thus allowing any possible position / La articulación de la base (A) puede rotar completamente. La cabeza también es giratoria (B) por lo que cualquier posición de la lámpara es posible.



0682.  
Chrome and white lacquer /  
Lacado blanco y cromo.

0683.  
Chrome and black lacquer /  
Lacado negro y cromo.



0683.

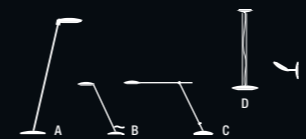

FLOOR LAMPS  
PIES

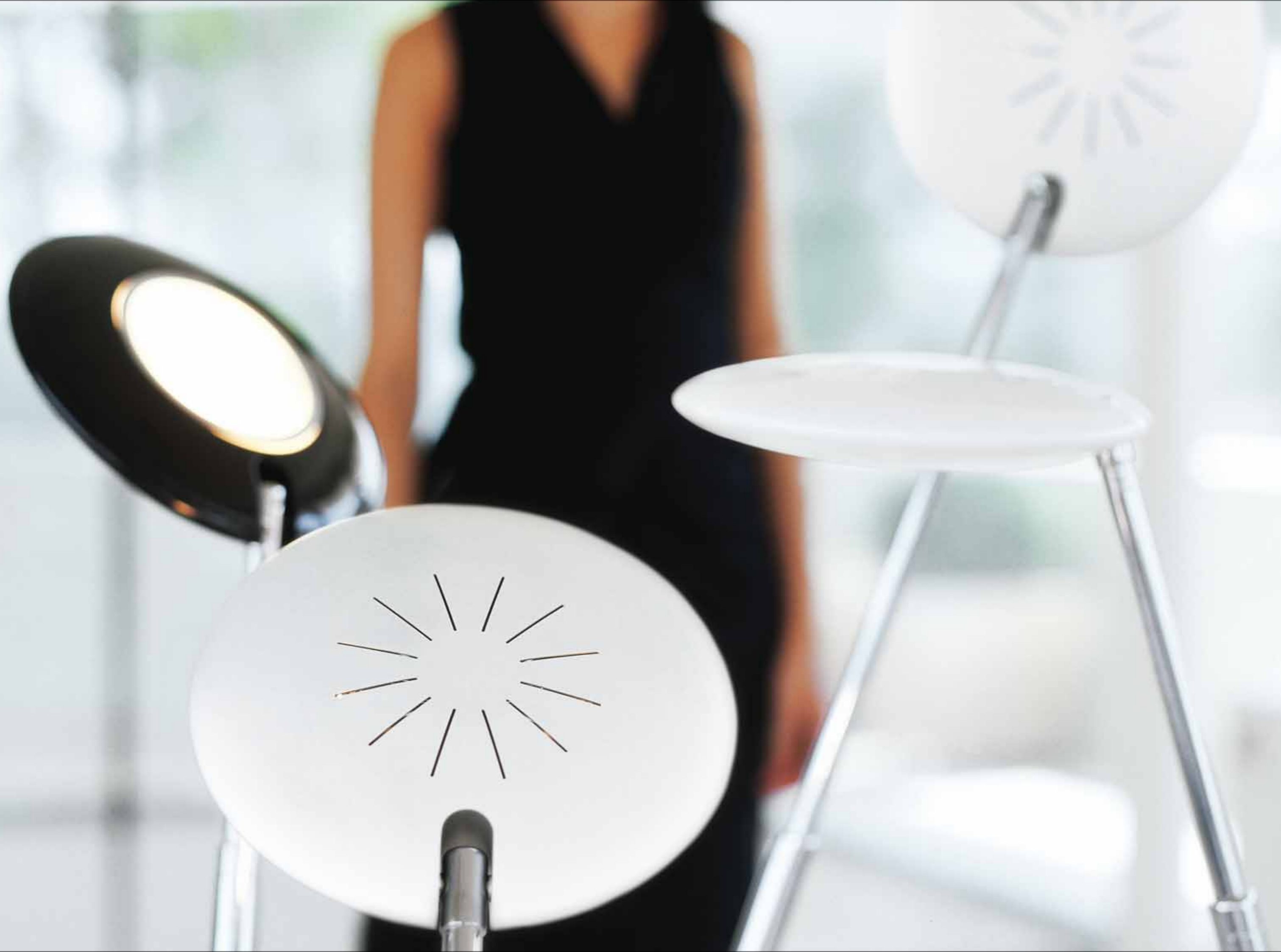

**Te**  
Design by Lievore, Altherr, Molina.

**5259.**  
Metallic silver / Lacado plata.  
R7s 117mm. 230V 500W Max.

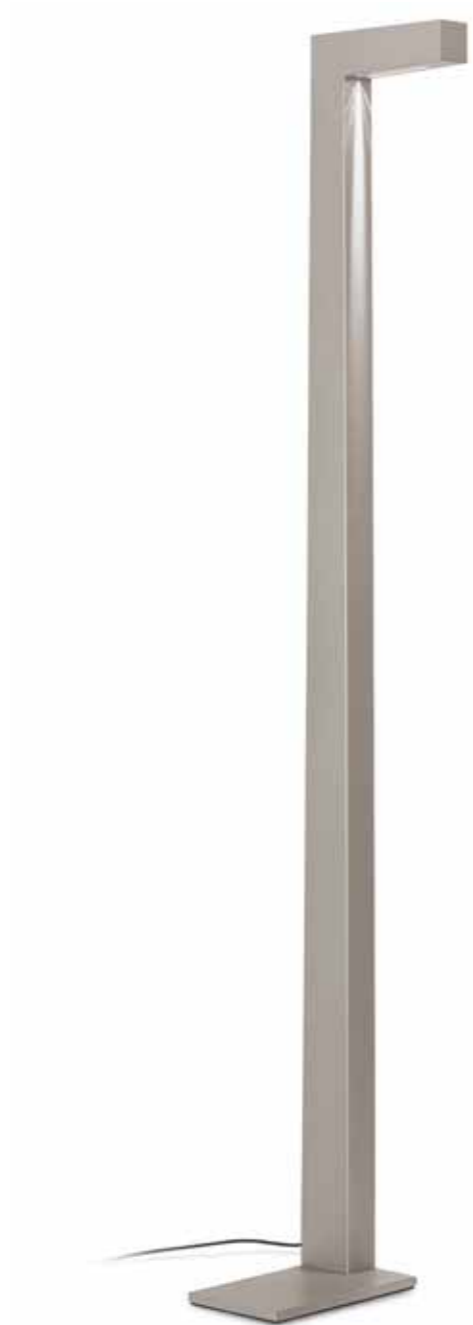
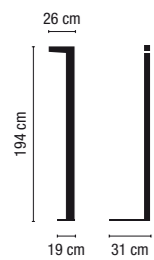

Dimmer on the cable /  
Con regulador de intensidad en el cable.

5259.



TE. Family / Familia  
Pages / Páginas: A-46. B-425. C-410. D-410.

FLOOR LAMPS  
PIES

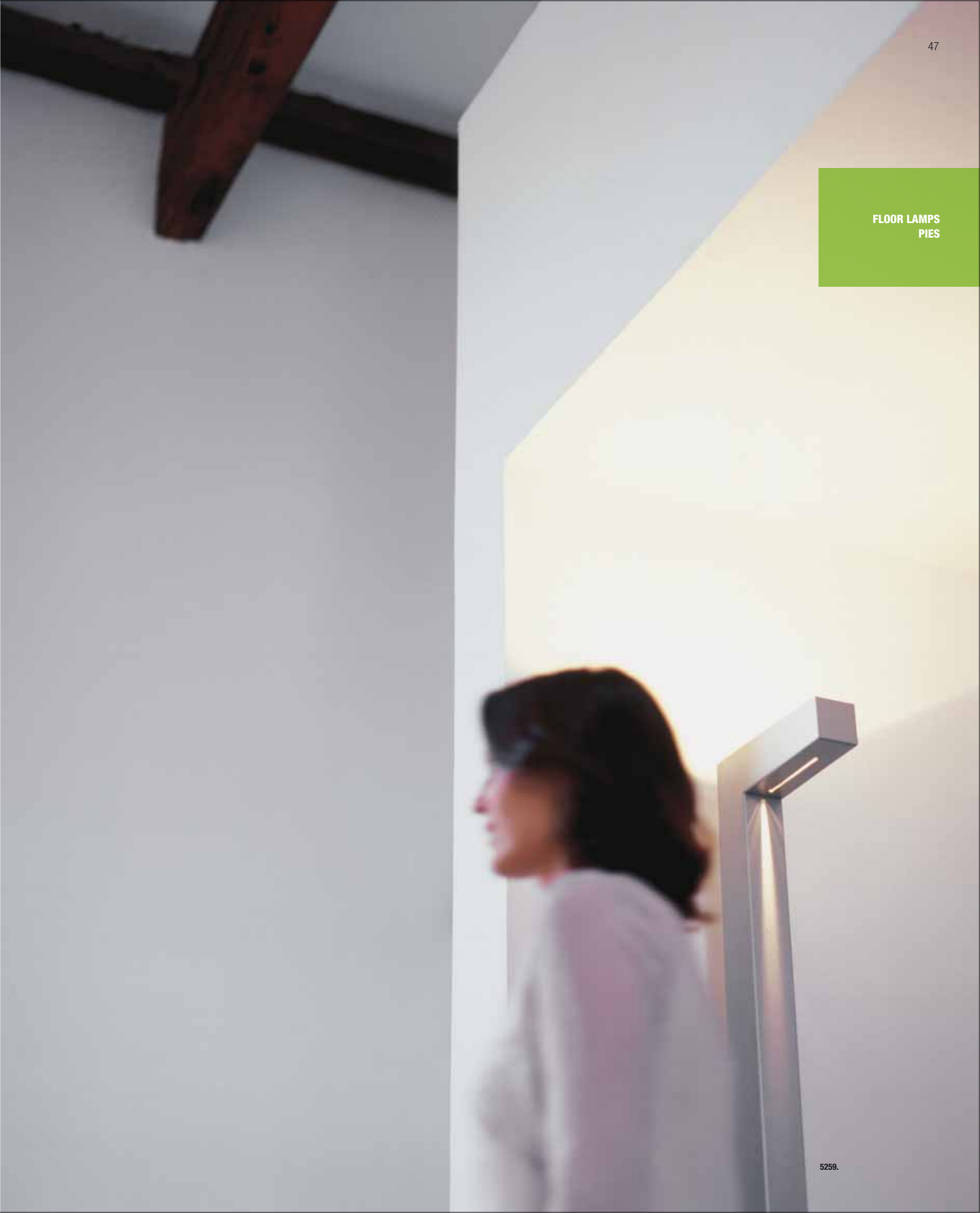

5259.

5220.

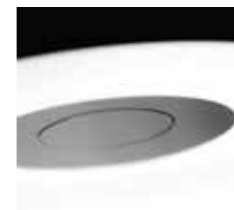
FLOOR LAMPS  
PIES

Matt opal triplex blown glass /  
Vidrio soplado opal mate triplex.

### Nadia

Design by G. Bernal & Associats.

#### 5220.

Chrome / Cromo.

Matt opal triplex blown-glass diffuser /  
Difusor de vidrio soplado opal mate triplex.

E27 Mate 150W Max.

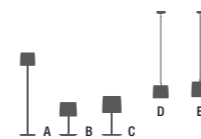
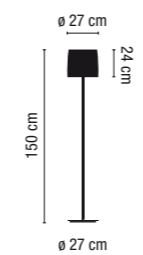

NADIA. Family / Familia

Pages / Páginas: A-49. B-125. C-125. D-184. E-184.



Switch on the cable / Interruptor en el cable.

5220.



**Kaos**

Design by X. Claramunt &amp; M. de Mas.

**1445.**

White lacquer / Lacado blanco.  
 Opal triplex blown-glass diffuser /  
 Difusor de vidrio soplado opal triplex.  
 4 x G9 230V 75W Max. (OSRAM HALOPIN).

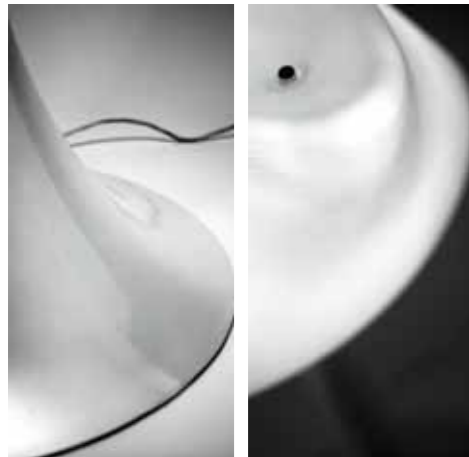
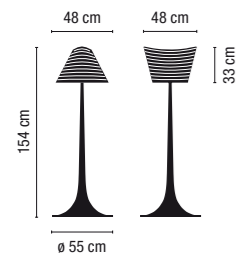

Switch on the cable.  
 Rigid high-density resin /  
 Interruptor en el cable.  
 Resina rígida de alta densidad.

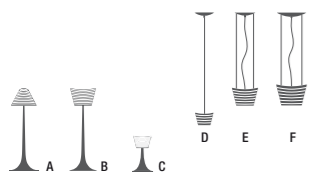

KAOS. Family / Familia

Pages / Páginas: A-50. B-50. C-102. D-180. E-180. F-180.



1445-03.

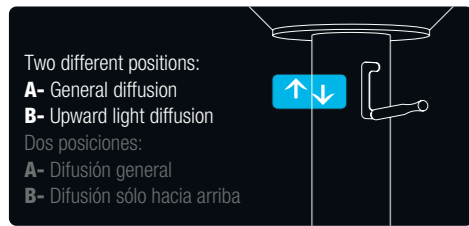
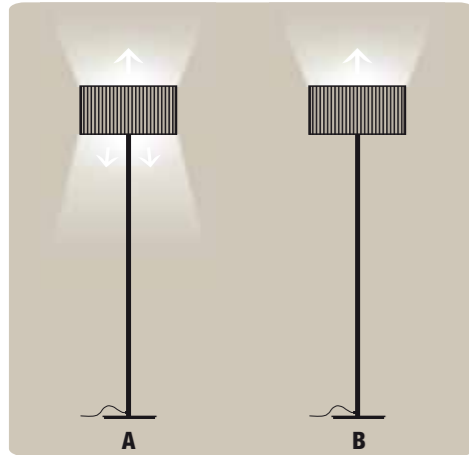

Two different positions:  
**A-** General diffusion  
**B-** Upward light diffusion  
 Dos posiciones:  
**A-** Difusión general  
**B-** Difusión sólo hacia arriba



**5194.** Metal-weft diffuser / Difusor de trama metálica.  
**5195.** Pleated-fabric diffuser / Difusor de tejido plisado.

**Duplo**  
 Design by Jordi Vilardell.

**5194 / 5195.**  
 Matt nickel / Niquel mate.  
**5194.** Metal-weft diffuser / Difusor de trama metálica.  
**5195.** Pleated-fabric diffuser / Difusor de tejido plisado.  
 Halógena Tubular E27 230V 250W Max.

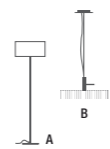
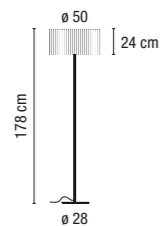

DUPL0. Family / Familia  
 Pages / Páginas: A-50. B-146.

Glass on the top /  
 Vidrio en la parte superior

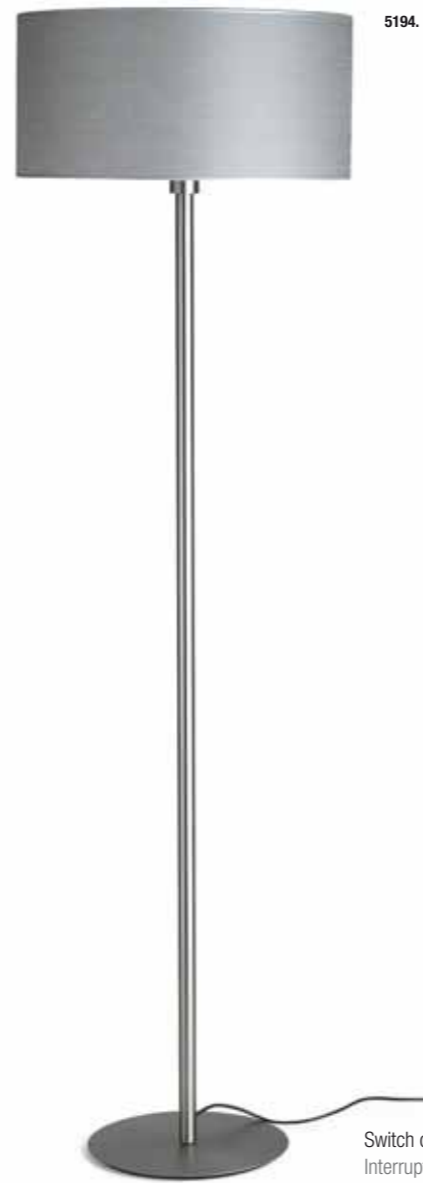

Switch on the cable /  
 Interruptor en el cable.

FLOOR LAMPS  
 PIES

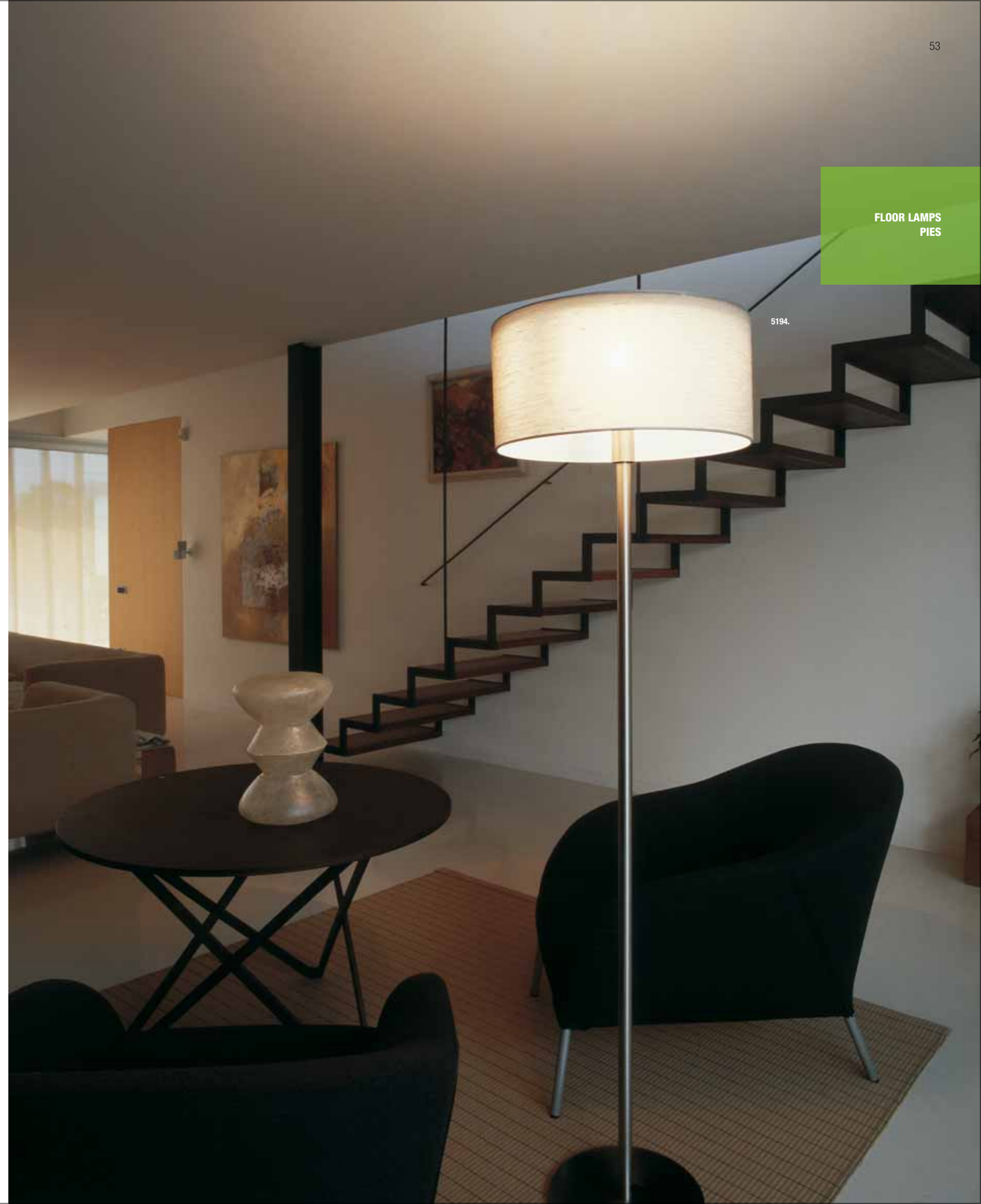



8160-60.

Double switch on the cable /  
Doble interruptor en el cable.

**Gigantic**  
Design by Estudi Blanc.

**8160 / 8161.**  
Black glamour / Negro glamour.  
Glamour textile, Fabric or metal-weft diffuser /  
Difusor tejido glamour, de algodón o difusor de trama metálica.  
3 x E27 Mate 230V 100W Max.  
E14 Esférica Mate 230V 60W Max.  
💡💡

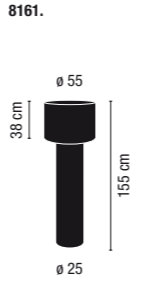
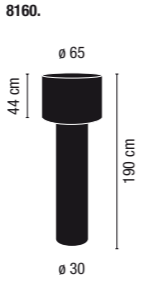

**8160-47 / 8161-47.**  
Black glamour  
textile diffuser / Difusor  
tejido glamour negro.

**8160-80 / 8161-80.**  
Fabric diffuser /  
Difusor de algodón.

**8160-60 / 8161-60.**  
Metal-weft diffuser /  
Difusor de trama metálica.



8160.

FLOOR LAMPS  
PIES



8161-60.

8160-60.

**Mast**

Design by Gemma Bernal and Ramón Isern.

**5030-30.**

Matt nickel / Níquel mate.  
White polymer diffuser / Difusor de polímero blanco.  
E27 Mate 150W Max.



**5030-01.**

Chrome / Cromo.  
Black chinz diffuser / Difusor de chinz negro.  
E27 Mate 150W Max.

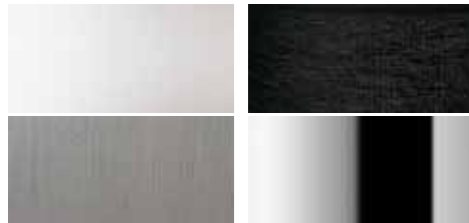
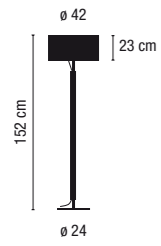

**5030-30.**

Matt nickel / Níquel mate.  
White polymer diffuser /  
Difusor de polímero blanco.

**5030-01.**

Chrome / Cromo.  
Black chinz diffuser /  
Difusor de chinz negro.

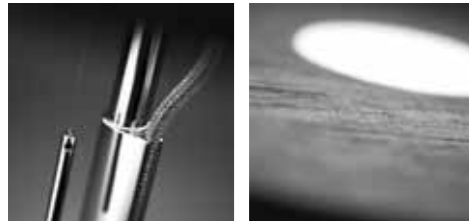

Pull switch /  
Interruptor tirador

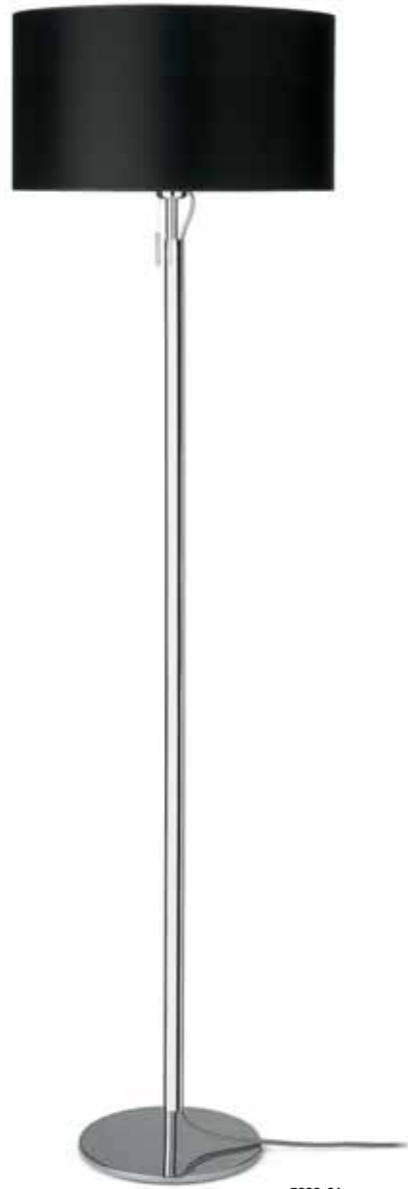

5030-01.

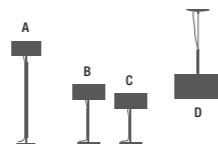

MAST. Family / Familia  
Pages / Páginas: A-58. B-118. C-118. D-168.

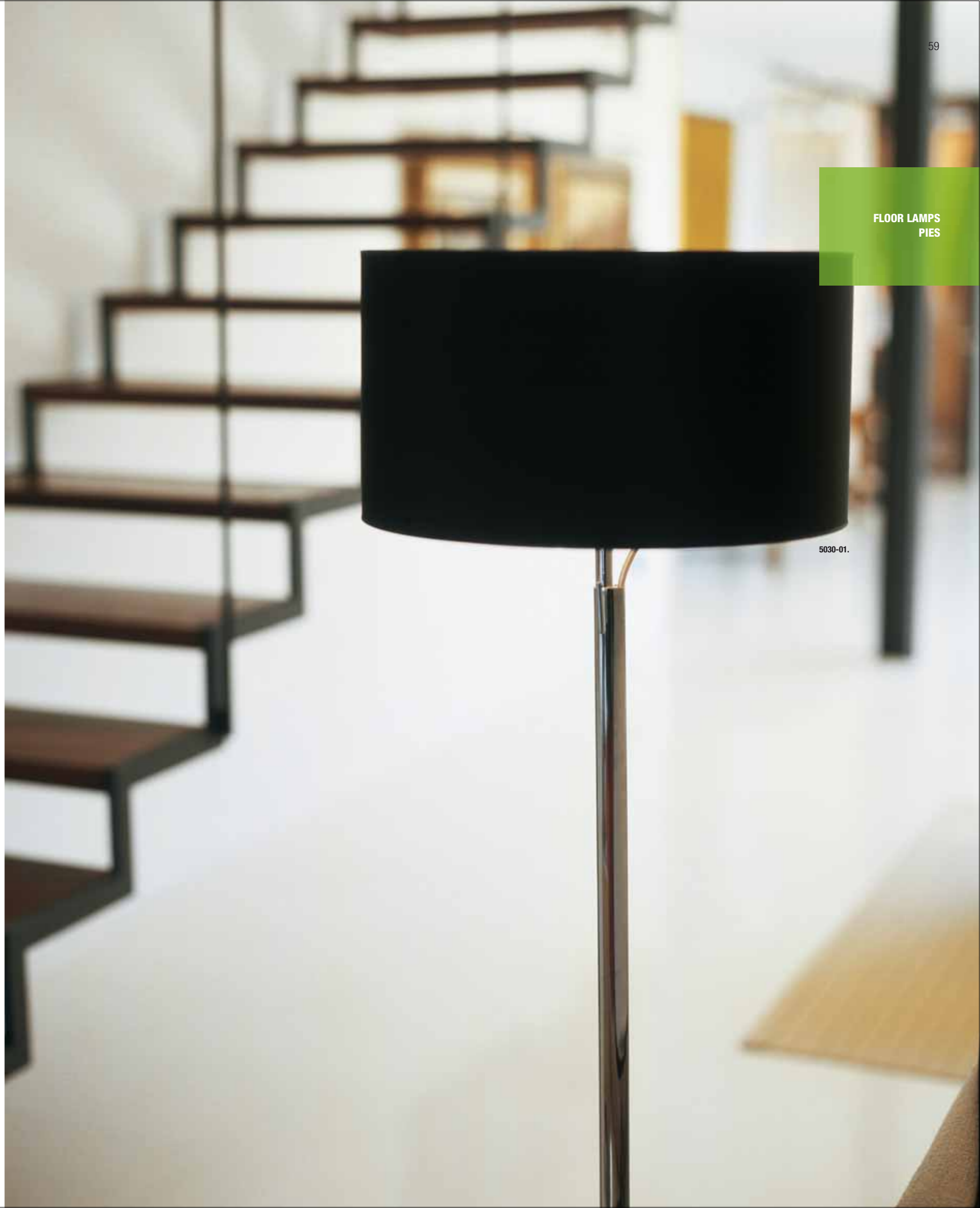

5030-01.

**Shell**

Design by Jordi Vilardell.

**5230.**

Chrome, matt nickel / Cromo, Niquel mate.  
Aluminium diffuser / Difusor de aluminio.  
R7s 117 mm. 230V 300W Max.

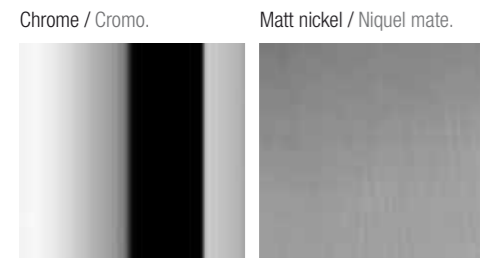
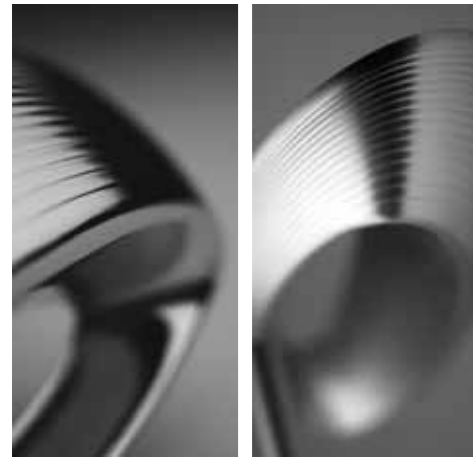
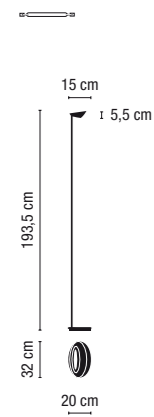

Dimmer on the cable / Regulador de intensidad en el cable.

5230.

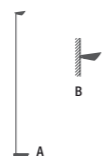

SHELL. Family / Familia  
Pages / Páginas: A-60. B-419.

FLOOR LAMPS  
PIES

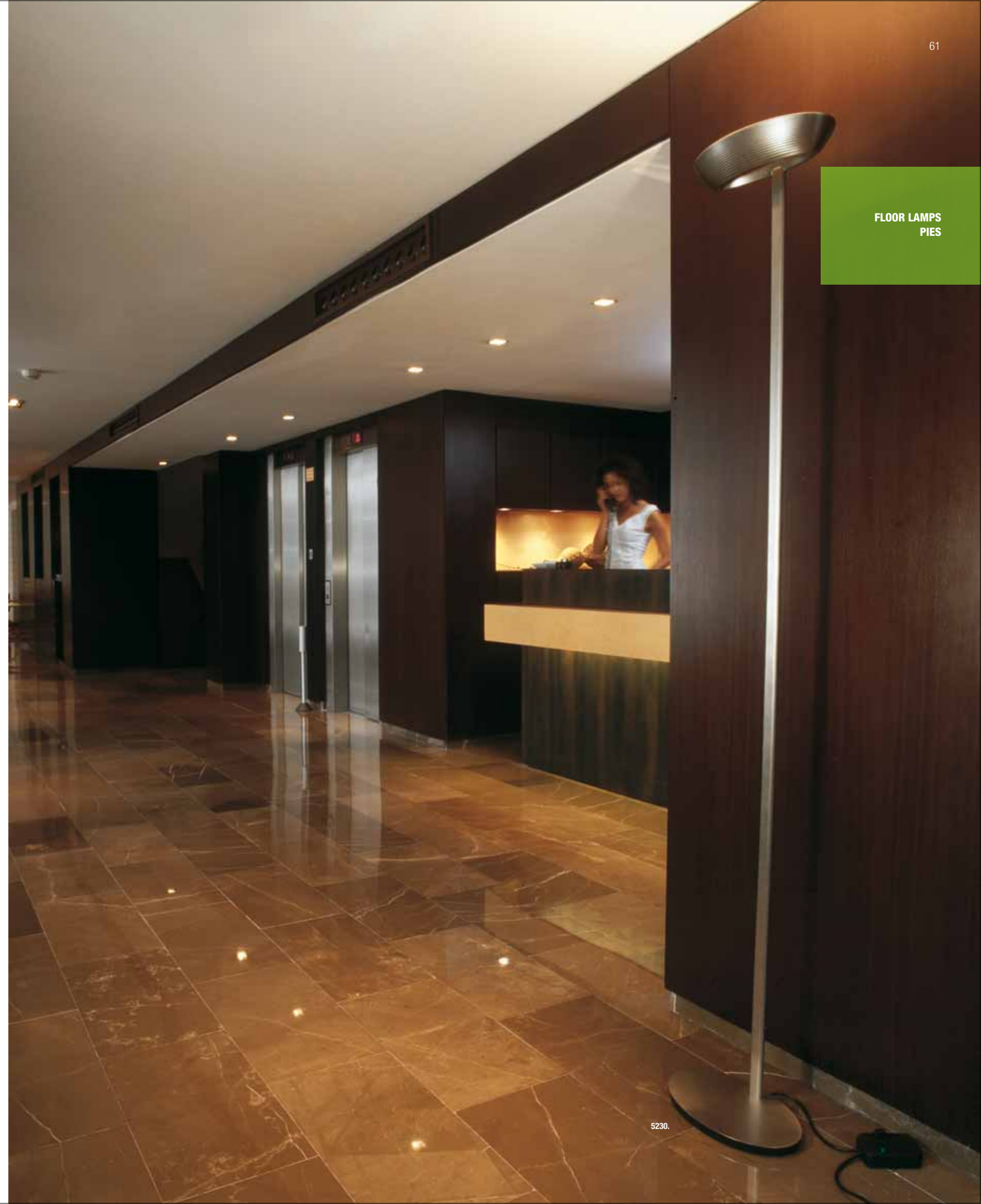

5230.

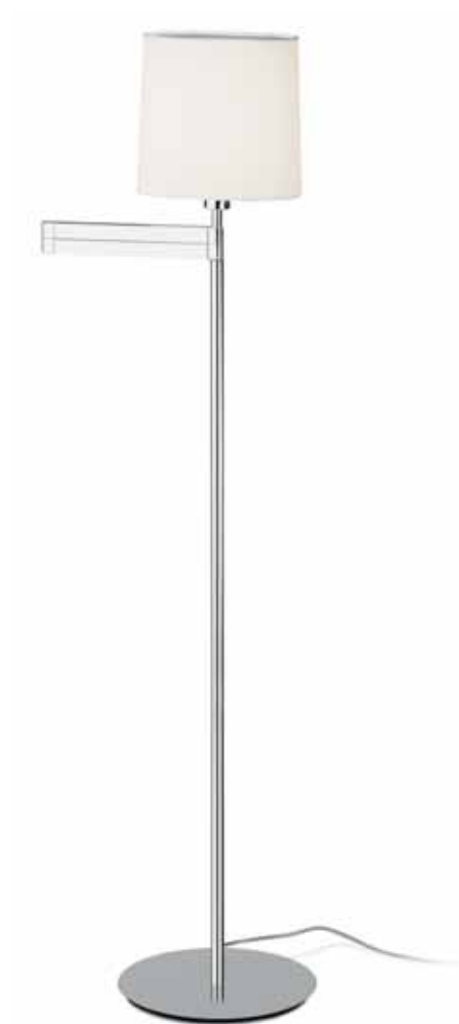

0501.

**Swing**

Design by Lievore, Altherr, Molina.

**0501.**

Chrome, matt nickel / Cromo, níquel mate.  
Fabric diffuser / Difusor de algodón.  
E27 Mate 230V 100W Max.



Chrome / Cromo.

Matt nickel / Níquel mate.

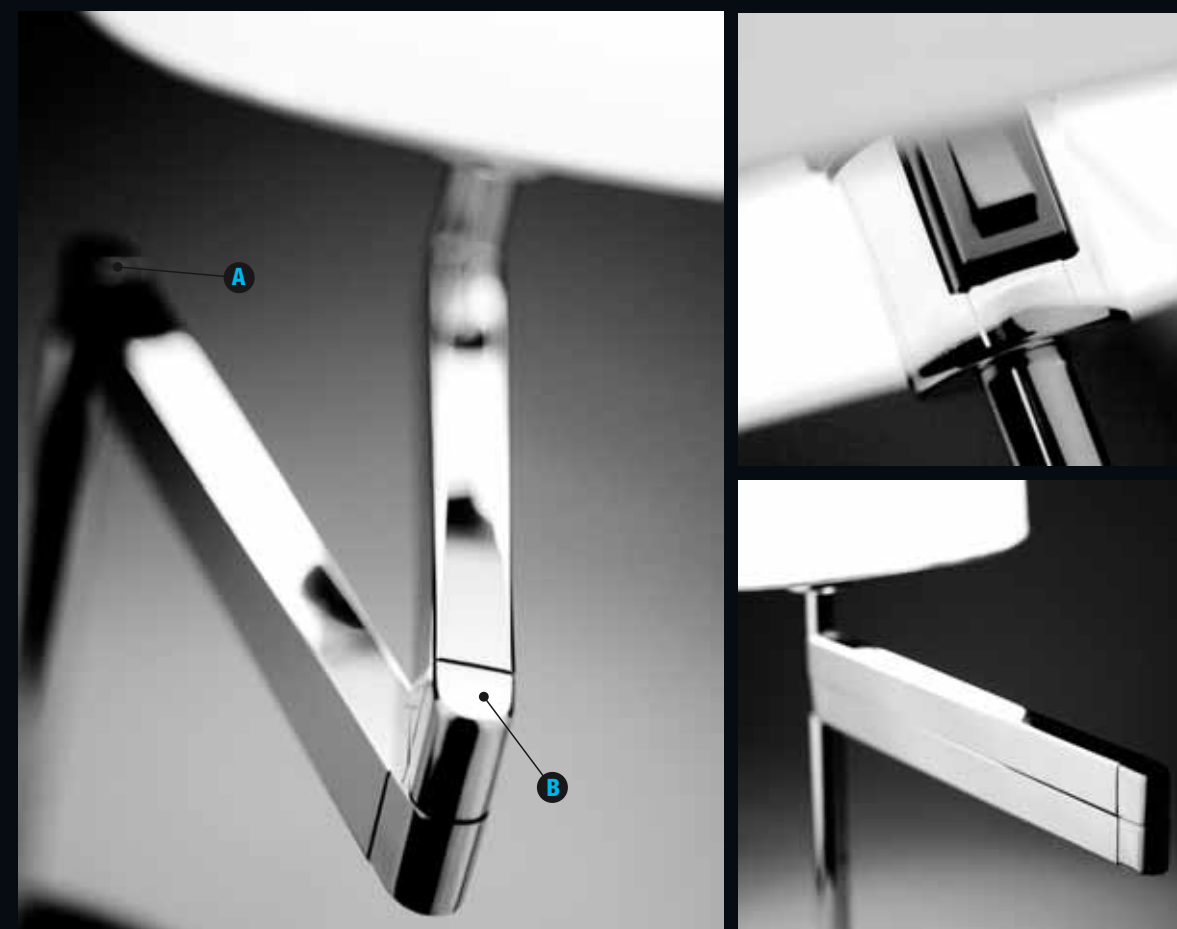

Double articulation (A+B) /  
Doble articulación (A+B).

Switch on the lampholder /  
Interruptor en el  
portalamparas.

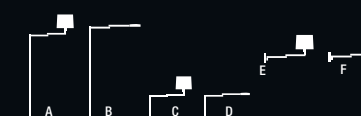
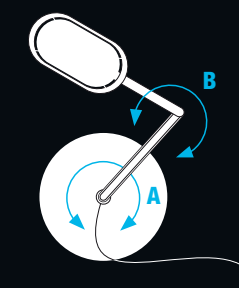

SWING. Family / Familia  
Pages / Páginas: A-62. B-66. C-116. D-114. E-440. F-444.

FLOOR LAMPS  
PIES



0501.



**Swing**

Design by Lievore, Altherr, Molina.

**0515.**

Chrome or matt nickel / Cromo o níquel mate  
Orientable steel diffuser / Difusor de acero orientable.  
G9 230V 60W Max. (OSRAM HALOPIN)

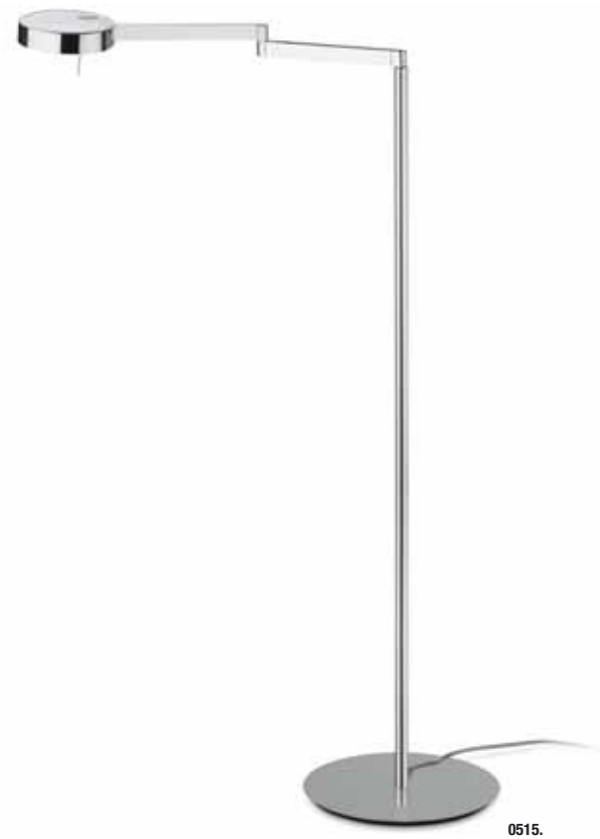
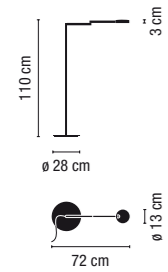

0515.

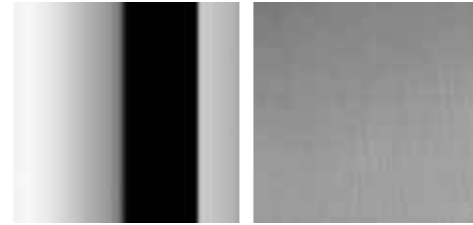

0515-01.  
Chrome / Cromo.

0515-30.  
Matt nickel / Níquel mate.



SWING. Family / Familia  
Pages / Páginas: A-62. B-66. C-116. D-114. E-440. F-444.

FLOOR LAMPS  
PIES

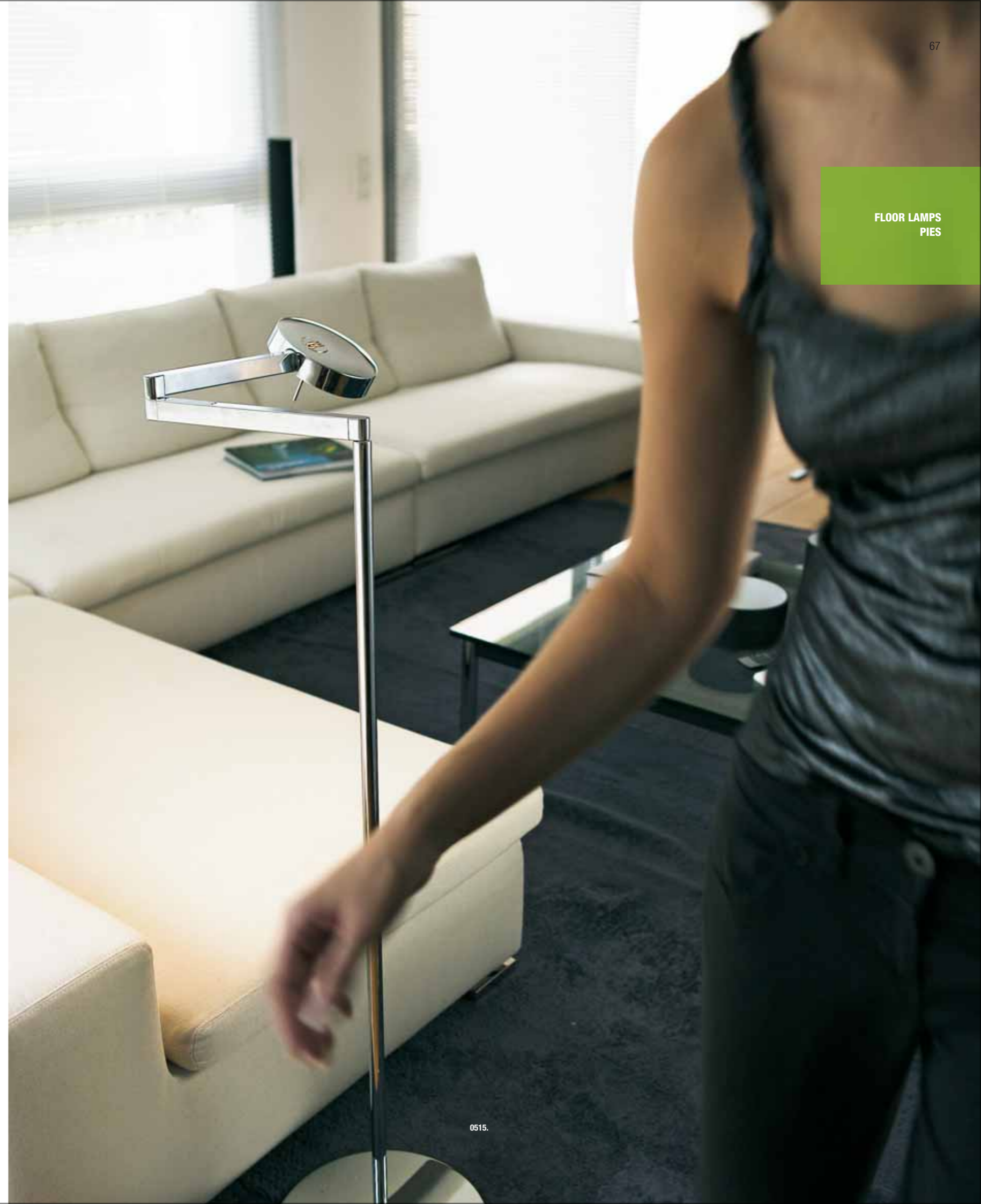

0515.

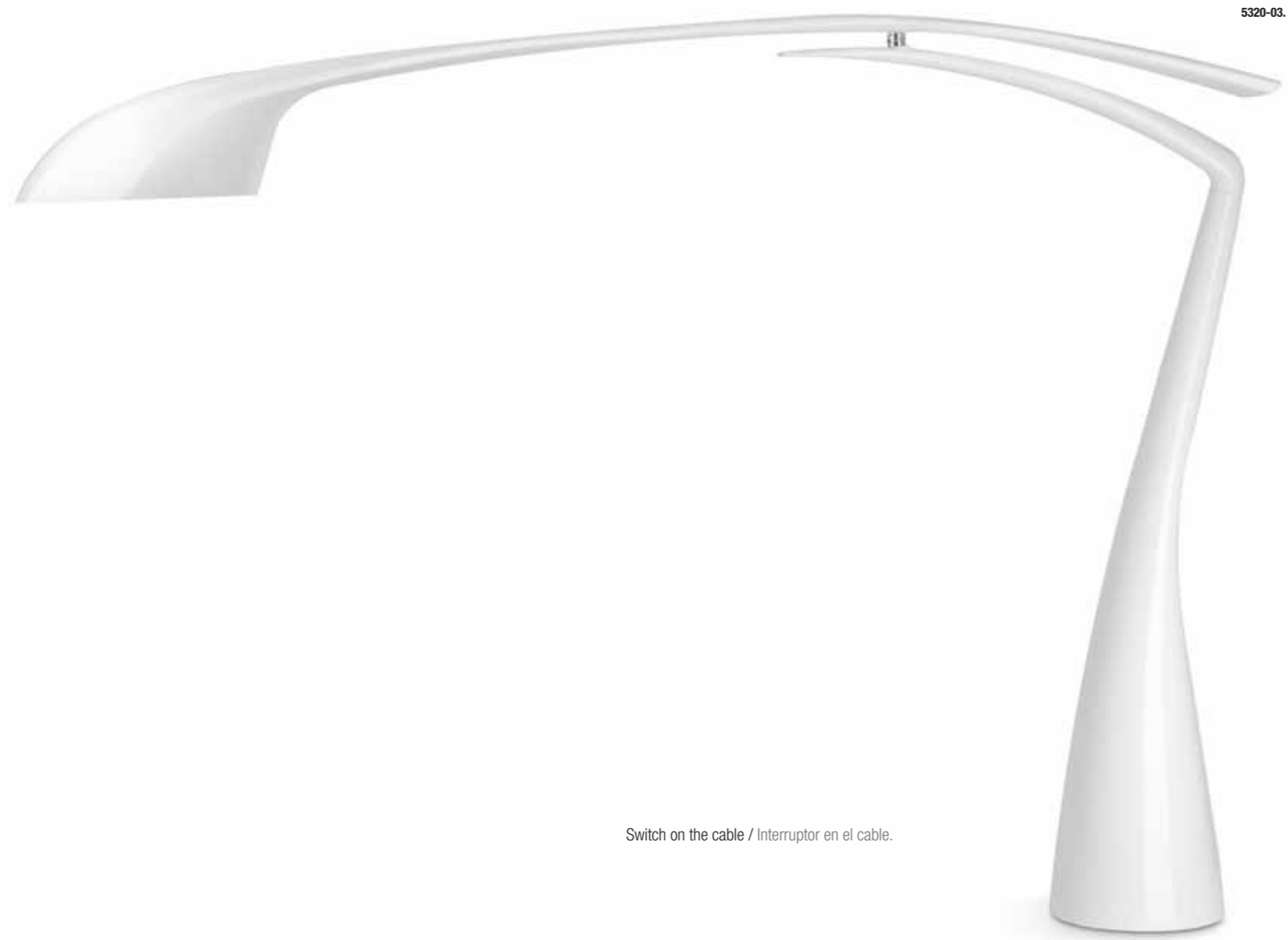

5320-03.

Switch on the cable / Interruptor en el cable.

**Samurai**  
Design by Robby Cantarutti.

**5320.**  
White lacquer, black lacquer and red lacquer /  
Lacado blanco, lacado negro y lacado rojo.  
Methacrylate diffuser / Difusor de metacrilato.  
2 x E27 30W (Osram Dulux E)

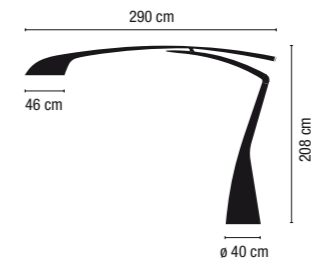

5320-03. White lacquer / Lacado blanco. 5320-04. Black lacquer / Lacado negro. 5320-06. Red lacquer / Lacado rojo.

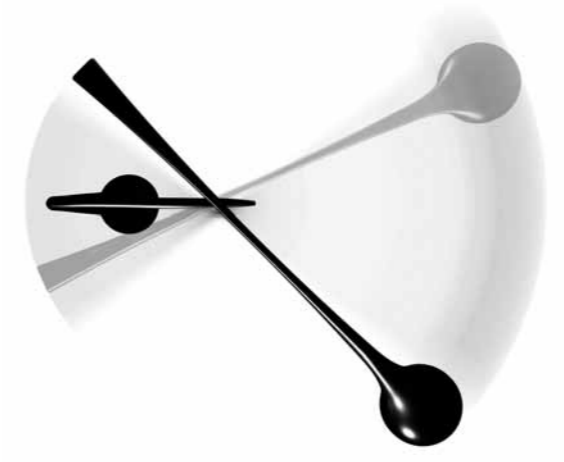

FLOOR LAMPS  
PIES



## Table Lamps Sobremesas

Aina	112
Code	130
Diva	104
Forest	91
Jazz	81/85/89
Join	92
Kaos	102
Lollipop	120
Mast	118
Nadia	125
Nature	79
Plis	99
Spaghetti	110
Sumo	128
Swing	114/116
Test	96
Tulip	106

TABLE LAMPS  
SOBREMESAS



1370-03.

### Nature

Design by Diego Fortunato.

#### 1370.

White lacquer, black lacquer and matt nickel /  
Lacado blanco, lacado negro y Niquel mate.  
Metal diffuser / Difusor metálico.  
4 x E14 Estérica Mate 60W Max.

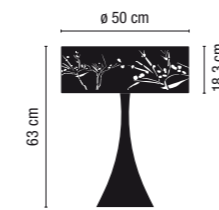

1370-03. White lacquer / Lacado blanco. 1370-04. Black lacquer / Lacado negro. 1370-30. Matt nickel / Niquel mate.

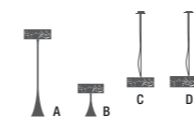

NATURE. Family / Familia  
Pages / Páginas: A-24. B-79. C-157. D-157.



Switch on the cable /  
Interrupor en el cable

1370-03.

1334-04.



Ø 45 cm

84,5 cm

Ø 26 cm

TABLE LAMPS  
SOBREMESAS



1334-03. White lacquer / Lacado blanco. 1334-04. Black lacquer / Lacado negro. 1334-06. Red lacquer / Lacado rojo.



1334-49. Silver finish / Acabado plata. 1334-51. Gold finish / Acabado oro.

**Jazz**  
Design by Diego Fortunato.

**1334.**  
White lacquer, black lacquer, red lacquer, gold finish or silver finish / Lacado blanco, lacado negro, lacado rojo, acabado oro y acabado plata.  
White, black, red, gold or silver metal shade / Pantalla metálica blanca, negra, roja, oro y plata.  
4 x E27 Mate 230V 60W Max.

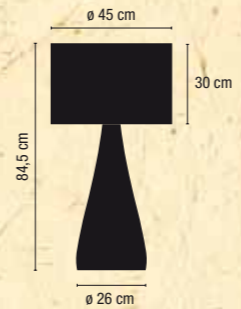

TABLE LAMPS  
SOBREMESAS



1334-51.



TABLE LAMPS  
SOBREMESAS

1333-03.



Ø 45 cm

72,5 cm

Ø 26 cm



1333-03.  
White lacquer / Lacado blanco.

1333-04.  
Black lacquer / Lacado negro.

1333-06.  
Red lacquer / Lacado rojo.



1333-49.  
Silver finish / Acabado plata.

1333-51.  
Gold finish / Acabado oro.

**Jazz**  
Design by Diego Fortunato.

**1333.**  
White lacquer, black lacquer, red lacquer,  
gold finish or silver finish /  
Lacado blanco, lacado negro, lacado rojo,  
acabado oro o acabado plata.  
White, black, red, gold or silver metal shade /  
Pantalla metálica blanca, negra, roja, oro, plata.  
4 x E27 Mate 230V 60W Max.

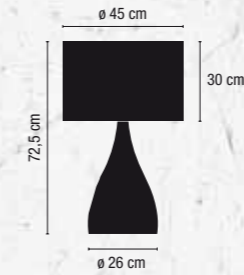

JAZZ. Family / Familia  
Pages / Páginas: A-19. B-81. C-89. D-85. E-89. F-186. G-188. H-190. I-190.

TABLE LAMPS  
SOBREMESAS



1333-49.

TABLE LAMPS  
SOBREMESAS

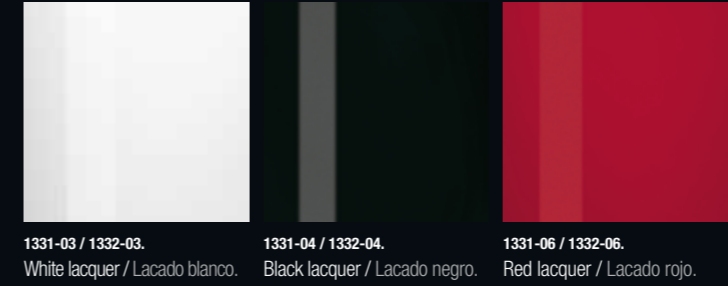

**Jazz**  
Design by Diego Fortunato.

**1331.**  
White lacquer, black lacquer or red lacquer /  
Lacado blanco, lacado negro o lacado rojo.  
White, black or red metal shade /  
Pantalla metálica blanca, negra o roja.  
3 x G9 230V 40 W Max. (OSRAM HALOPIN)

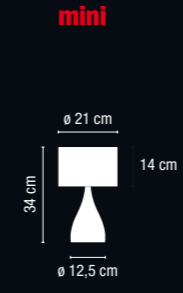

**1332.**  
White lacquer, black lacquer or red lacquer /  
Lacado blanco, lacado negro o lacado rojo.  
White, black or red metal shade /  
Pantalla metálica blanca, negra o roja.  
3 x G9 230V 40W Max. (OSRAM HALOPIN)

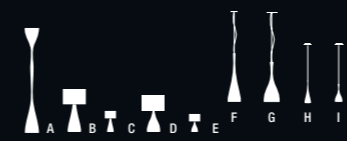
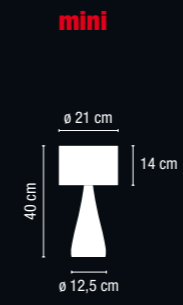

JAZZ. Family / Familia  
Pages / Páginas: A-19. B-81. C-89. D-85. E-89. F-186. G-188. H-190. I-190.

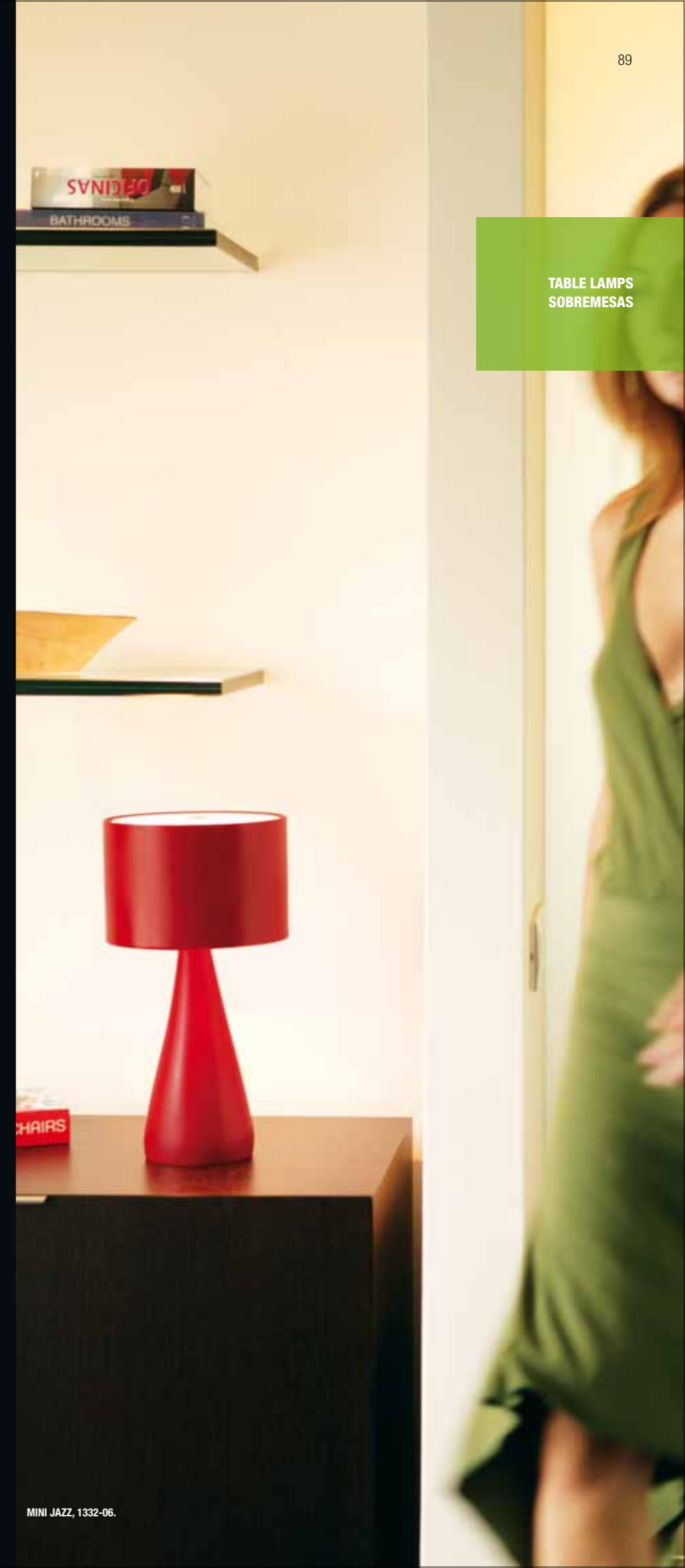

**Forest**

Design by Ramos &amp; Bassols.

**5285.**

Chrome / Cromo.  
Wengue wood diffuser / Difusor madera wengué.  
4 x E14 Estérica Mate 60W Max.

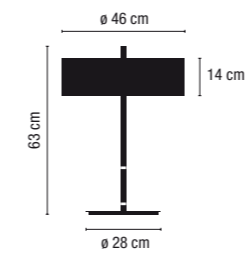

Black glass disc /  
Disco de vidrio negro



Optical glass on top and white  
methacrylate disc on the bottom /  
Vidrio óptico superior y disco  
metacrilato blanco inferior.



FOREST. Family / Familia

Pages / Páginas: A-22. B-91. C-158. D-158.



Switch on the cable /  
Interrupor en el cable.

5285.



Switch on the cable / Interruptor en el cable.

**Join**  
Design by Jordi Vilardell.

**5065 / 5066.**  
Borosilicate glass / Vidrio de borosilicato.  
G9 230V 60W Max. (OSRAM HALOPIN).  
⚡

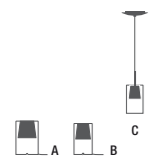
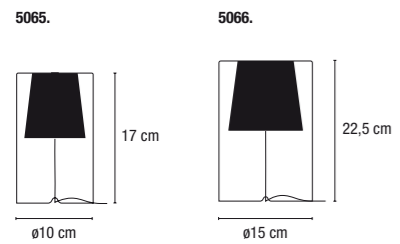

TABLE LAMPS  
SOBREMESAS

5066.

5065.

5065.

5066.

TABLE LAMPS  
SOBREMESAS





Switch on the cable / Interruptor en el cable.

5093.



**Test**

Design by X. Claramunt & M. de Mas.

**5093.**

Borosilicate glass / Vidrio de borosilicato.  
G9 230V 60W Max (OSRAM HALOPIN).

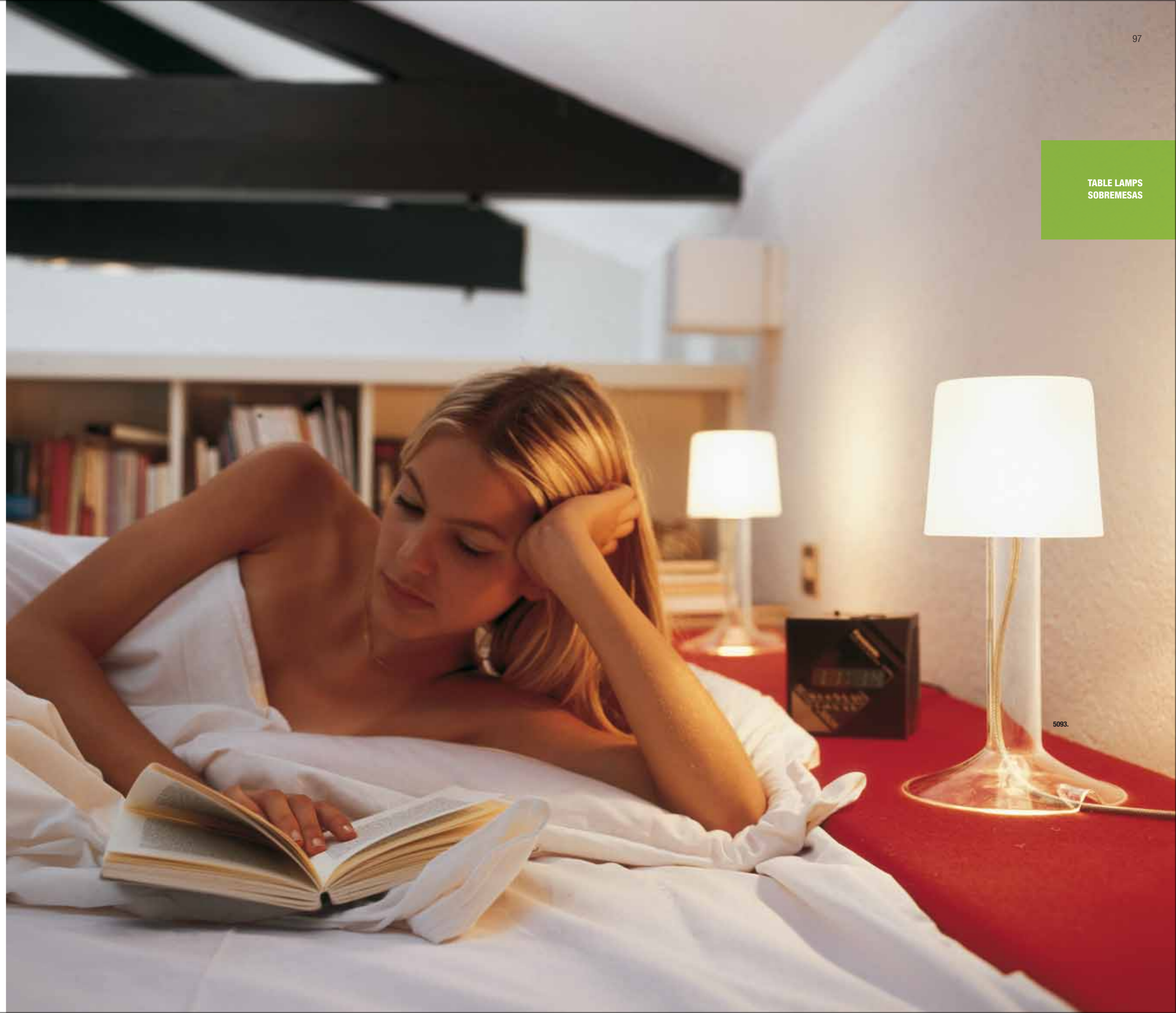
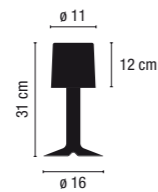

5093.

Upper methacrylate plate / Disco superior de metacrilato.



5110.



5116.



**5110 / 5115**  
Cream cotton ribbon diffuser /  
Difusor de cinta de algodón  
color crudo.



**5111 / 5116**  
Black cotton ribbon diffuser /  
Difusor de cinta de  
algodón negro.



**5112 / 5117**  
Red cotton ribbon diffuser /  
Difusor de cinta de  
algodón roja.



Cotton ribbon /  
Cinta de algodón.

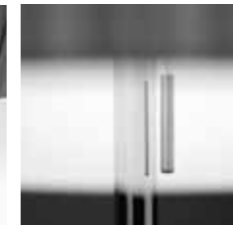

Double Pull Switch /  
Interruptor tirador de doble  
encendido.

**Plis**  
Design by G. Bernal & Associats.

**5110 / 5111 / 5112.**

Chrome / Cromo.

**5110:** Cream cotton ribbon diffuser / Difusor de cinta de algodón color crudo.

**5111:** Black cotton ribbon diffuser / Difusor de cinta de algodón negro.

**5112:** Red cotton ribbon diffuser / Difusor de cinta de algodón rojo.

2 x E27 Esférica Mate 60W Max.

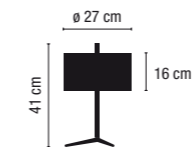

**5115 / 5116 / 5117.**

Chrome / Cromo.

**5115:** Cream cotton ribbon diffuser / Difusor de cinta de algodón color crudo.

**5116:** Black cotton ribbon diffuser / Difusor de cinta de algodón negro.

**5117:** Red cotton ribbon diffuser / Difusor de cinta de algodón rojo.

2 x E27 Mate 100W Max.

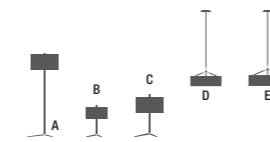
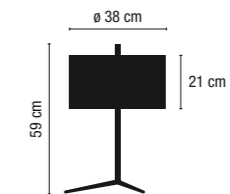

PLIS. Family / Familia  
Pages / Páginas: A-26. B-99. C-99. D-152. E-152.



TABLE LAMPS  
SOBREMESAS



5110.

**Mini Kaos**

Design by X. Claramunt and M. de Mas.

**1449.**

White lacquer / Lacado blanco.

Matt opal triplex blown-glass diffuser /

Difusor de vidrio soplado opal mate triplex.

G9 230V 75W Max. (OSRAM HALOPIN).

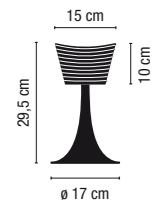

Switch on the cable / Interruptor en el cable.

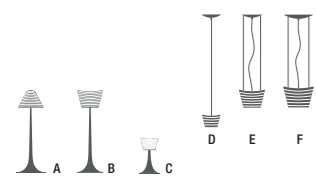

KAOS. Family / Familia

Pages / Páginas: A-50. B-50. C-102. D-180. E-180. F-180.

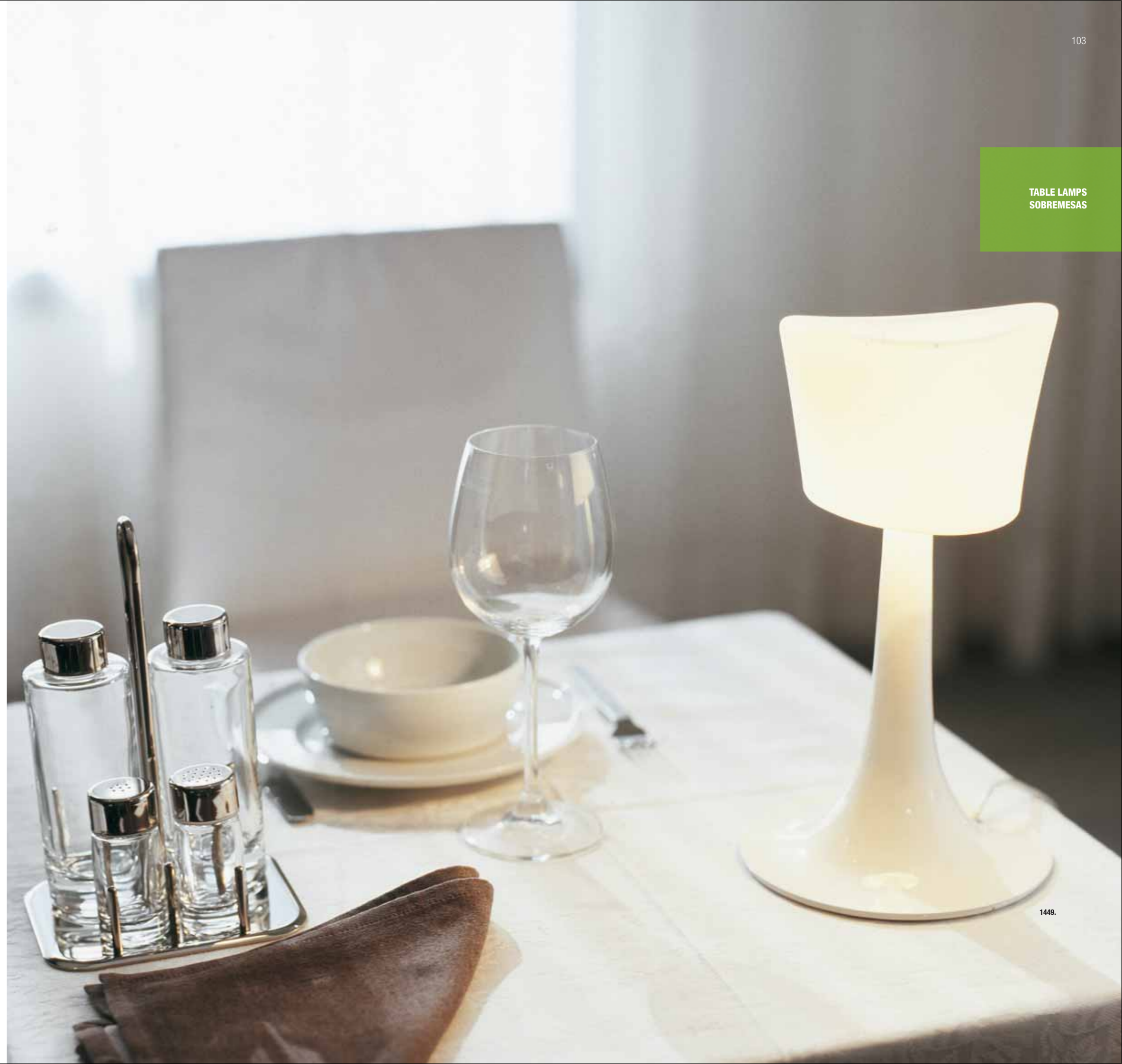

1449.

### Diva

**0650 / 0655.**  
 Silver lacquer, chrome / Lacado plata, cromo.  
 Metal diffuser / Difusor de metal.  
**0650:** With base / Con base.  
**0655:** With clamp / Con pinza.  
 E27 60W Max.



0650.

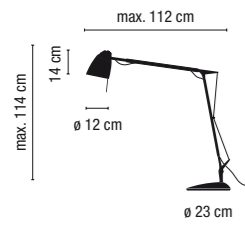

0655.

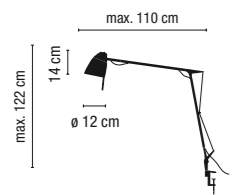

### MiniDiva

**0652.**  
 Silver lacquer / Lacado plata.  
 Metal diffuser / Difusor de metal.  
 GX53 9W.

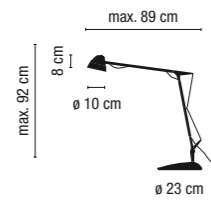

Silver lacquer / Lacado plata.



Chrome / Cromo.



Switch on top of the diffuser / Interruptor en la parte superior.

max 112 cm



0650.

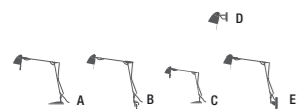

0650.

**Tulip**

Design by Lievore, Altherr, Molina.

**0351 / 0352.**

Chrome / Cromo.

Matt opal triplex blown-glass diffuser /

Difusor de vidrio soplado opal mate triplex.

E14 Esférica Mate 60W Max.



0351.

0352.

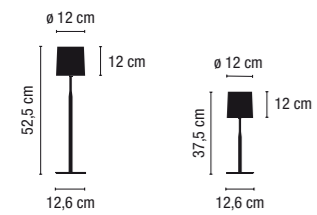

Switch on the cable /  
Interruptor en el cable.

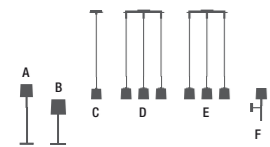

TULIP, Family / Familia

Pages / Páginas: A-106. B-106. C-166. D-166. E-166. F-422.

TABLE LAMPS  
SOBREMESAS

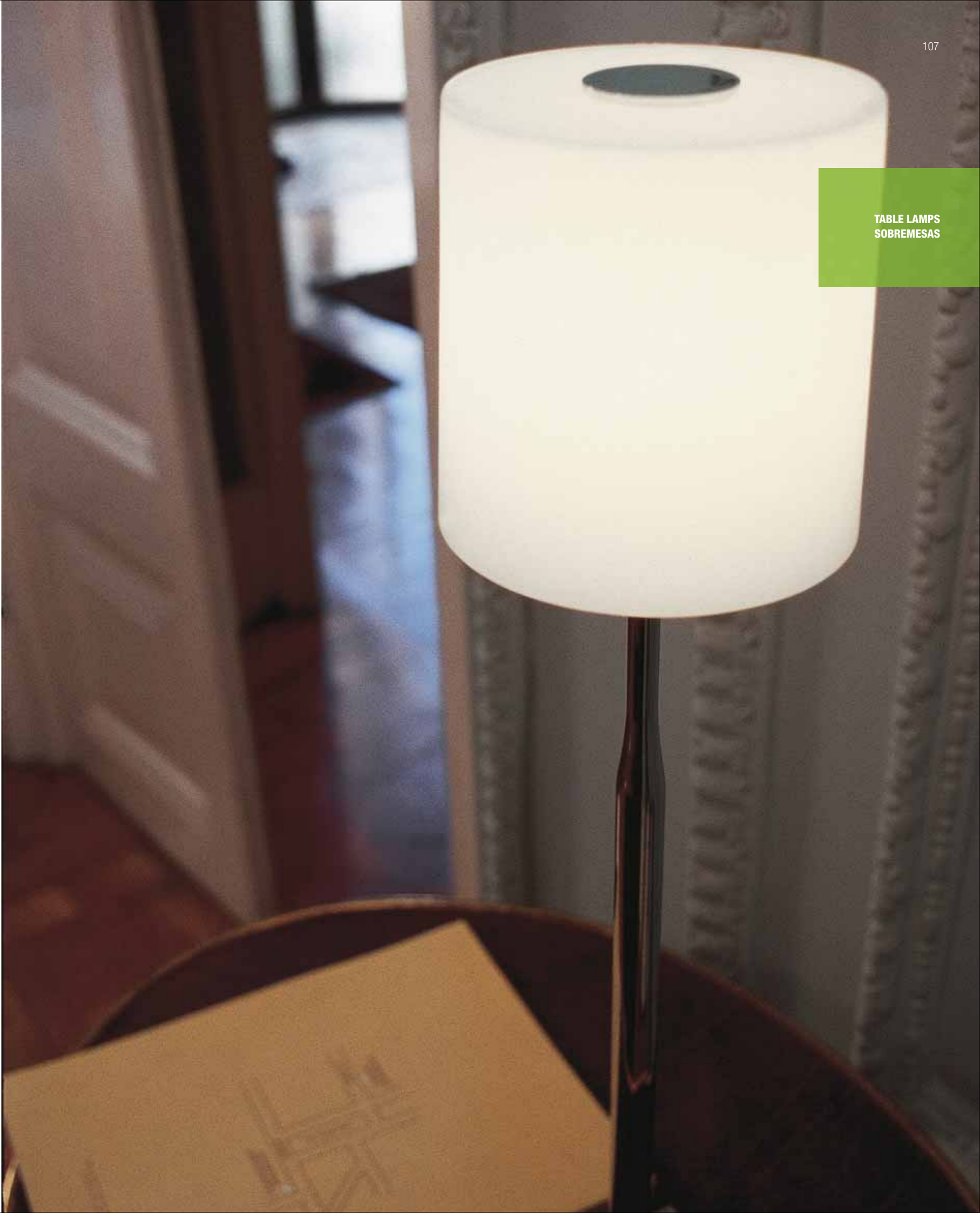

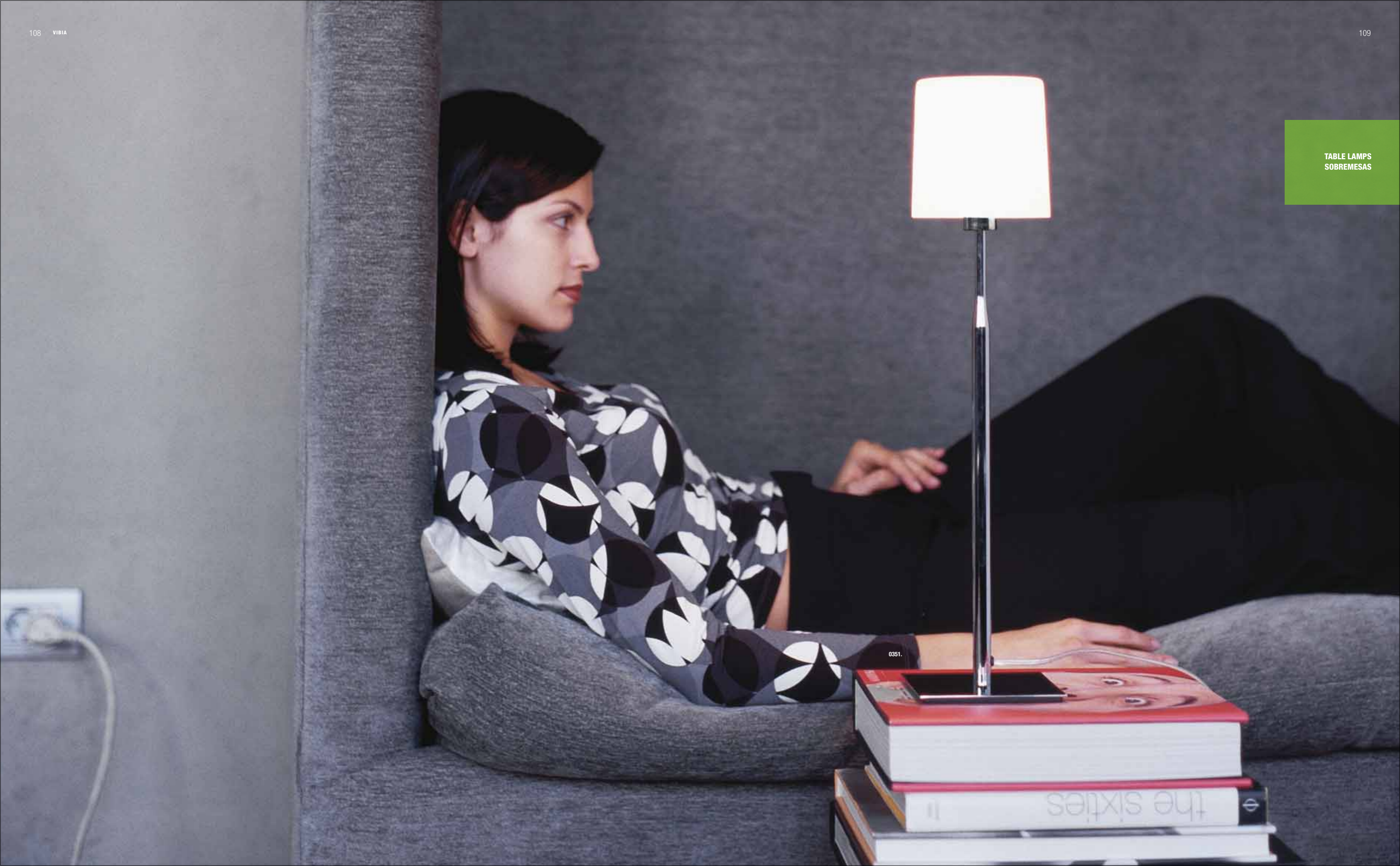

TABLE LAMPS  
SOBREMESAS

0351.

the sixties

**Spaghetti**  
Design by Ramón Benedito.

**1097.**  
Matt nickel or chrome /  
Níquel mate o cromo.  
FM 11W (OSRAM T2).

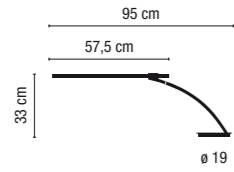

Switch on the base / Interruptor en la base.

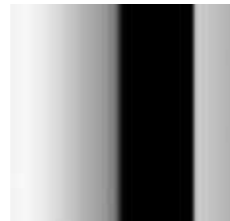

Chrome / Cromo.



Matt nickel / Níquel mate.

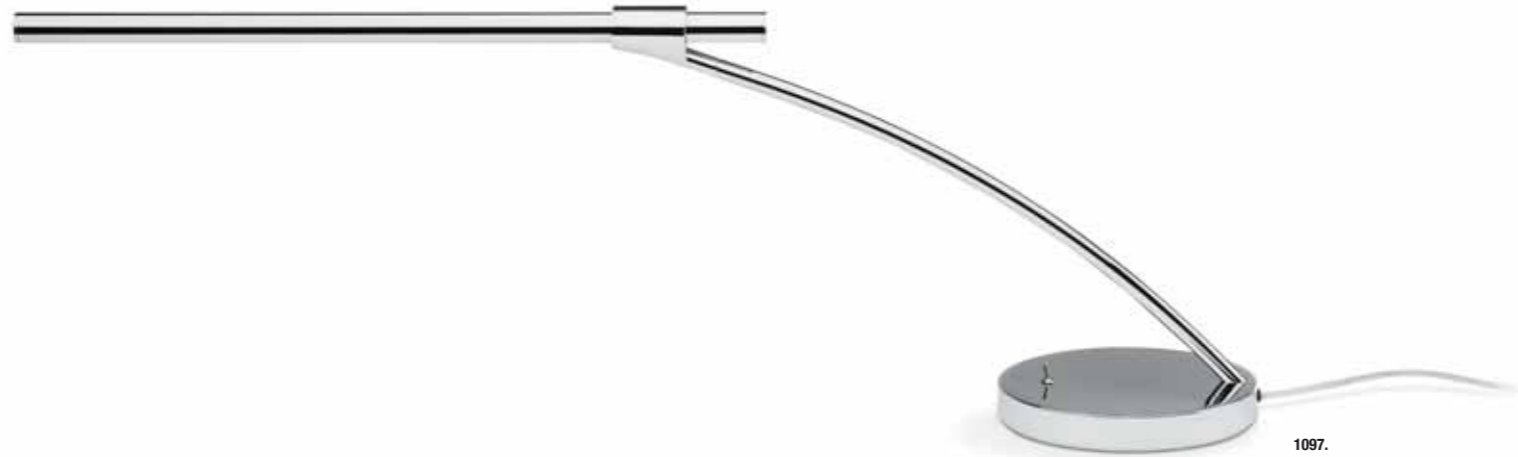

1097.

NEW CHROME FINISH / NUEVO ACABADO CROMO

TABLE LAMPS  
SOBREMESAS



1097.

**Aina**

Design by Jordi Vilardell.

**5137 / 5138.**

Matt nickel / Niquel mate .  
 Porcelain diffuser / Difusor de porcelana.  
 2 x G9 230V 75W Max.(OSRAM HALOPIN).

5137.

5138.

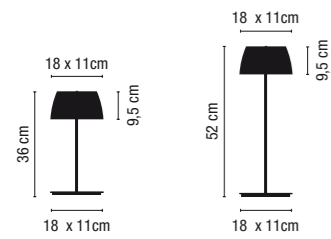

Porcelain diffuser. Glass on the top. Switch on the base / Difusor de porcelana. Vidrio en la parte superior. Interruptor en la base.

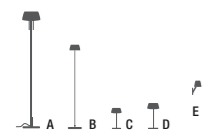

AINA. Family / Familia  
 Pages / Páginas: A-38. B-40. C-112. D-112. E-426.

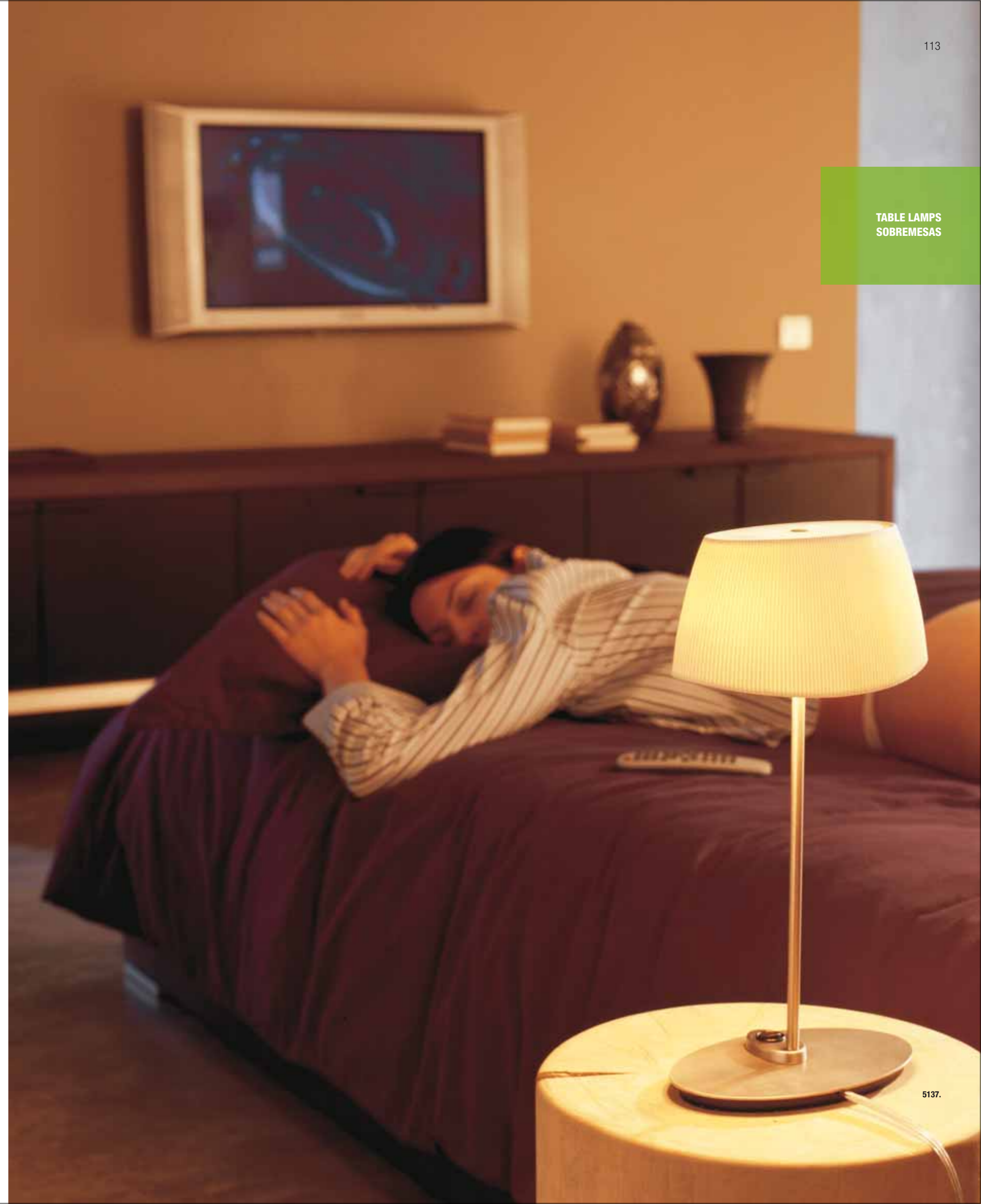

5137.



Switch on the cable /  
Interruptor en el cable.

0520.

**Swing**

Design by Lievore, Altherr, Molina.

**0520.**

Chrome, matt nickel / Cromo, níquel mate.  
Metal diffuser / Difusor de metal orientable.  
G9 230V 60W Max. (OSRAM HALOPIN).

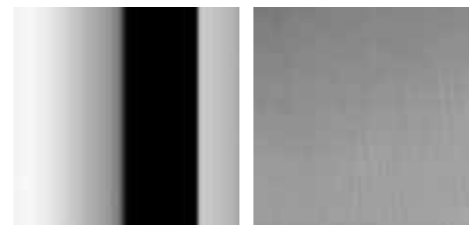

Chrome / Cromo.

Matt nickel / Níquel mate.

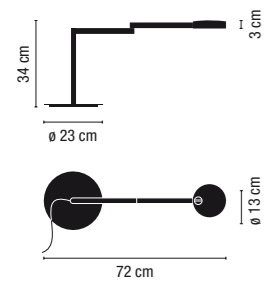

SWING. Family / Familia  
Pages / Páginas: A-62. B-66. C-116. D-114. E-440. F-444.

TABLE LAMPS  
SOBREMESAS

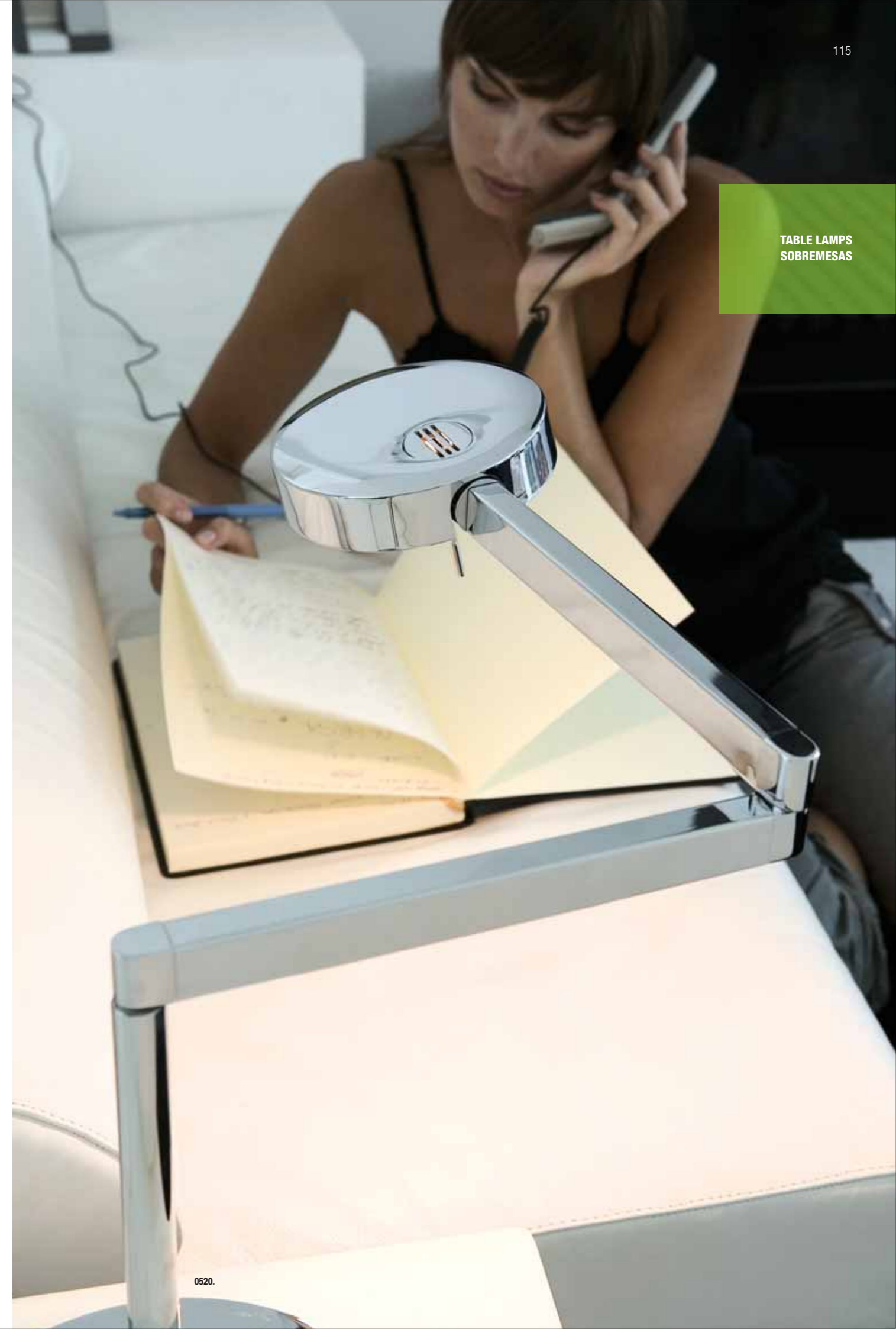

0520.



**Swing**

Design by Lievore, Altherr, Molina.

**0506.**

Chrome, matt nickel / Cromo, níquel mate.  
Fabric diffuser / Difusor de algodón.  
E27 Mate 230V 100W Max.

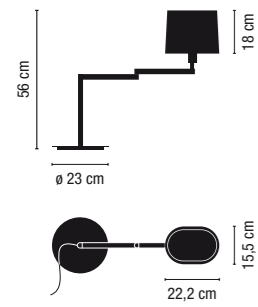

0506.

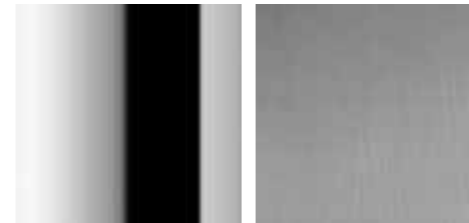

Chrome / Cromo.

Matt nickel / Níquel mate.

Switch on the lampholder /  
Interruptor en el portalamparas.

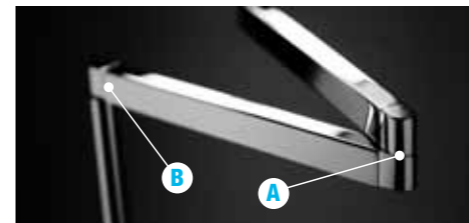

Double articulation (A+B) /  
Doble articulación (A+B).

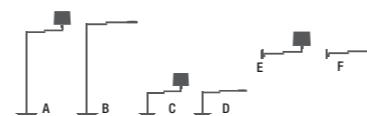
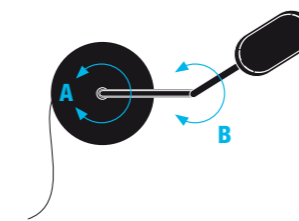

SWING. Family / Familia  
Pages / Páginas: A-62. B-66. C-116. D-114. E-440. F-444.

TABLE LAMPS  
SOBREMESAS



0506.

**Mast**

Design by Gemma Bernal and Ramón Isern.

**5028-30 / 5031-30.**

Matt nickel / Niquel mate.  
White polymer diffuser / Difusor de polímero blanco.

**5028-30:** E27 Mate 100W Max.

**5031-30:** E27 Mate 150W Max.



**5028-01 / 5031-01.**

Chrome / Cromo.  
Black Chinz diffuser / Difusor de Chinz negro.

**5028-01:** E27 Mate 100W Max.

**5031-01:** E27 Mate 150W Max.



5028.

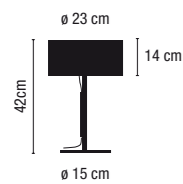

5031.

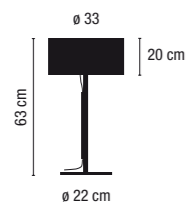

**5028-30 / 5031-30.**

Matt nickel / Niquel mate.  
White polymer diffuser / Difusor de polímero blanco.

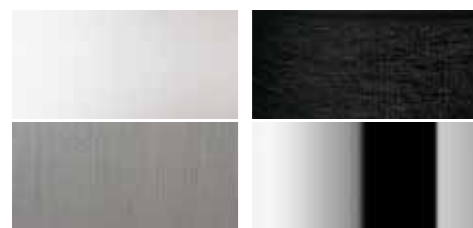

**5028-01 / 5031-01.**

Chrome / Cromo.  
Black Chinz diffuser / Difusor de Chinz negro.

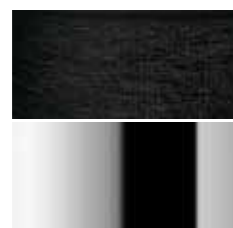

Pull switch / Interruptor tirador.

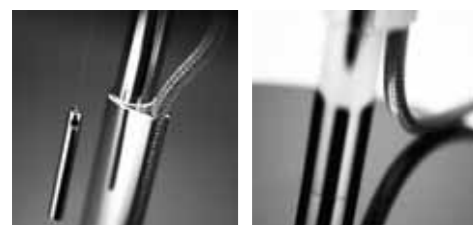

5031-30.

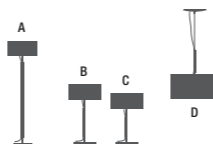

MAST. Family / Familia  
Pages / Páginas: A-58. B-118. C-118. D-168.

TABLE LAMPS  
SOBREMESAS



5031-01.



5028-30.

**Mini Lollipop**

Design by Hopf & Wortman, büro für form.

**0675.**

White lacquer or black lacquer /  
Lacado blanco, lacado negro.  
Borosilicate diffuser / Difusor de vidrio de borosilicato.  
G9 230V 40W Max (OSRAM HALOPIN).

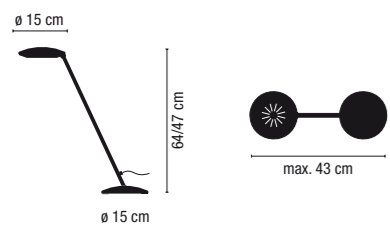

**0677.**

White lacquer or black lacquer /  
Lacado blanco, lacado negro.  
Borosilicate diffuser / Difusor de vidrio de borosilicato.  
G9 230V 40W Max (OSRAM HALOPIN).

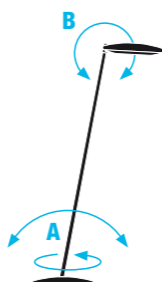
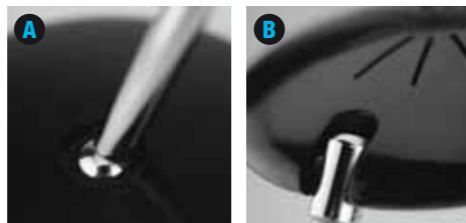
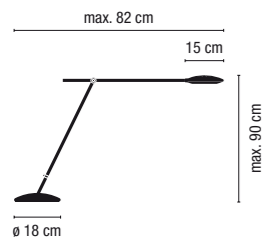

The base articulation (A) allows any position. Also the lamp head is completely adjustable (B), thus allowing any possible position / La articulación de la base (A) puede rotar completamente. La cabeza también es giratoria (B) por lo que cualquier posición de la lámpara es posible



0675-03 / 0677-03. White lacquer / Lacado blanco. 0675-04 / 0677-04. Black lacquer / Lacado negro.

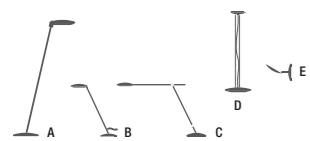

TABLE LAMPS  
SOBREMESAS

mini

Ø 15 cm



0675-04.

Ø 15 cm

max 64 cm

mini

Ø 15 cm



0677-03.

Ø 18 cm

max 90 cm

TABLE LAMPS  
SOBREMESAS



mini  
0677-03.



5222.

5224.

Switch on the cable / Interruptor en el cable.

**Nadia**

Design by G. Bernal and Associats.

**5222 / 5224.**

Chrome / Cromo.  
Matt / Mate.  
Matt opal triplex blown-glass diffuser /  
Difusor de vidrio soplado opal triplex.

**5222:** E27 Mate 100W Max.



**5224:** E27 Mate 150W Max.

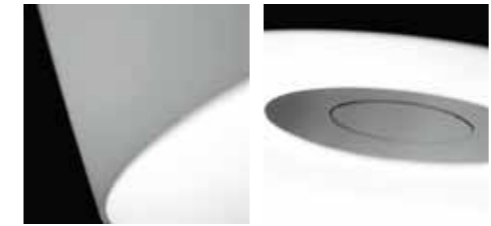
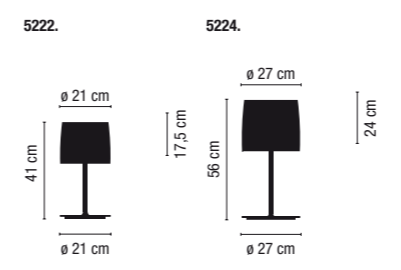

Matt opal triplex blown-glass / Vidrio soplado opal mate triplex.

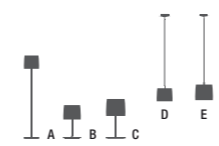

NADIA. Family / Familia  
Pages / Páginas: A-49. B-125. C-125. D-184. E-184.

TABLE LAMPS  
SOBREMESAS

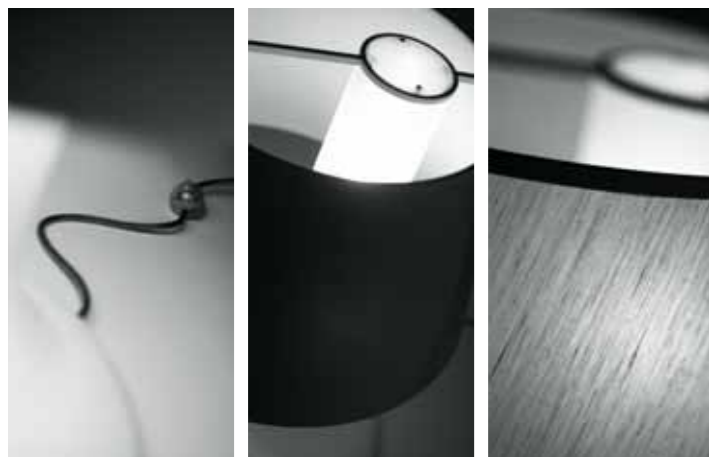

TABLE LAMPS  
SOBREMESAS

5224.

5224.





Switch on the cable / Interruptor en el cable. Borosilicate inner glass / Vidrio interior de borosilicato. Lamé diffuser / Tejido especial Lamé.



**1505.** White metal shade / Pantalla metálica blanca. **1506.** Lamé diffuser / Pantalla Lamé.

**Sumo**  
Design by Robby Cantarutti.

**1505 / 1506.**  
White lacquered / Lacado blanco.  
**1505:** White metal shade / Pantalla metálica blanca.  
**1506:** Lamé diffuser / Pantalla Lamé.  
Halógena Tubular E14 230V 100W Max.

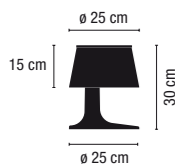

1506.

Ø 25 cm

TABLE LAMPS  
SOBREMESAS

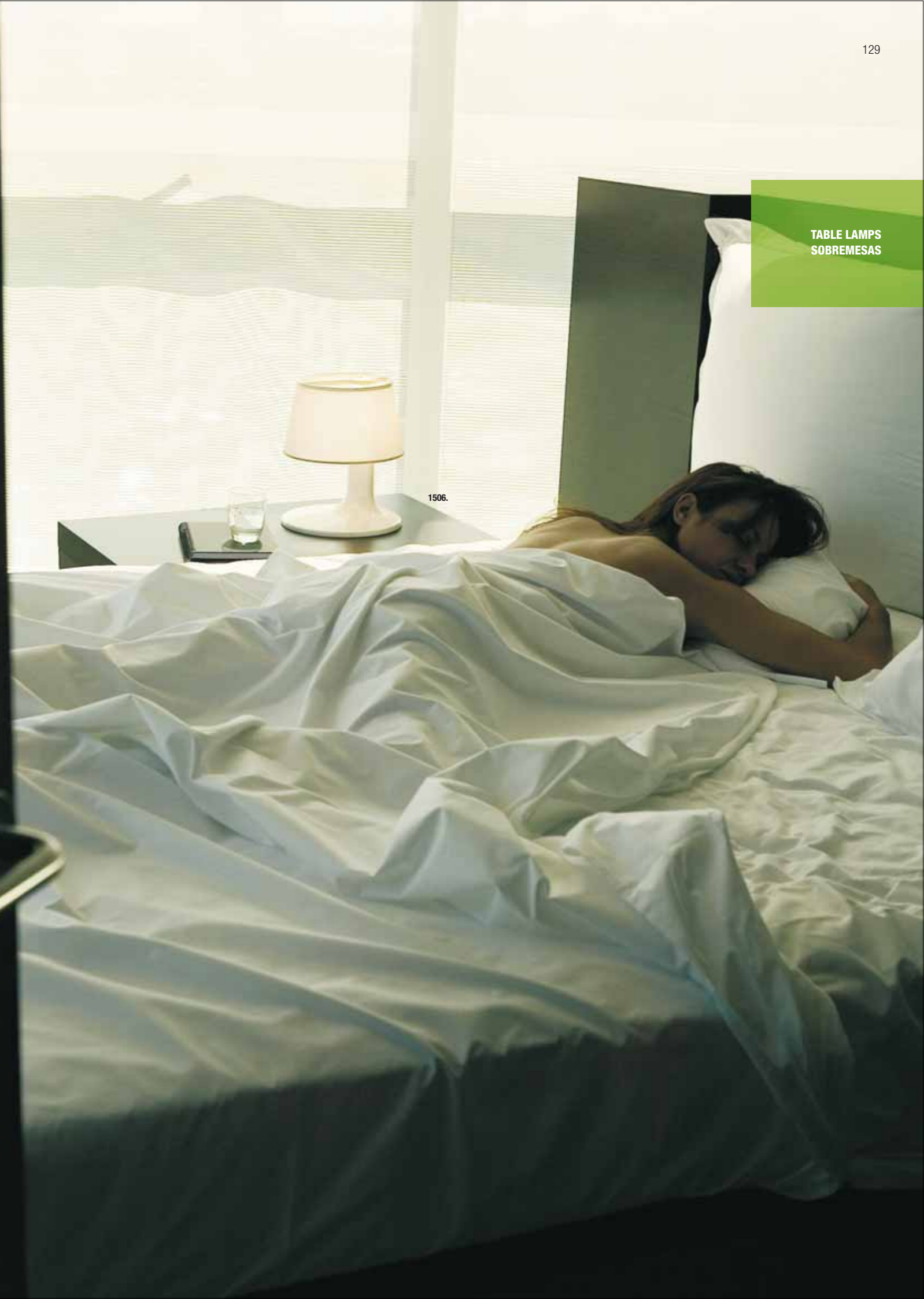

1506.



2101-03. White lacquer / Lacado blanco. 2101-04. Black lacquer / Lacado negro.



**Code**

Design by Diego Fortunato.

**2101.**

White lacquer or black lacquer / Lacado blanco y lacado negro.  
 Triplex blown-glass diffuser / Difusor de vidrio soplado triplex.  
 4 x E14 Mate 230V 60W Max.

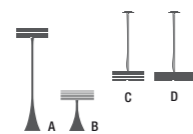
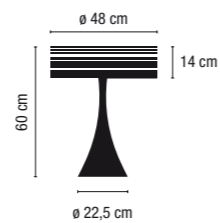

CODE. Family / Familia  
 Pages / Páginas: A-14. B-86. C-86. D-134.



Switch on the cable / Interruptor en el cable.

2101-03.

TABLE LAMPS  
 SOBREMESAS



2101-03.



# Hanging Lamps Colgantes

Code	139
Corner	208/210
Duplo	160
Eight	172/174/177
Even	206
Forest	158
Glenn	194
Infinity	140
Iso	170
Jazz	186/188/190
Join	192
Kaos	180
Lollipop	198
Lotto	178
Mast	168
Moving	162/164
Nadia	184
Nature	157
Nobel	183
Plis	153
Puzzle	200
Sixties	196
Slim	144/148
Slim	150
Tulip	166

2103.

Ø 60 cm

HANGING LAMPS  
COLGANTES





2102.

**Code**

Design by Diego Fortunato.

**2102 / 2103.**

White lacquer / Lacado blanco.  
 Triplex blown-glass diffuser /  
 Difusor de vidrio soplado triplex.  
 4 x E14 230V 60W Max.



2102.

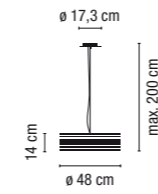

2103.

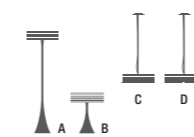
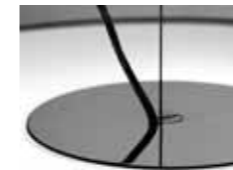
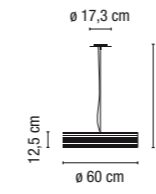

CODE: Family / Familia  
 Pages / Páginas: A-14. B-86. C-86. D-134.

HANGING LAMPS  
 COLGANTES

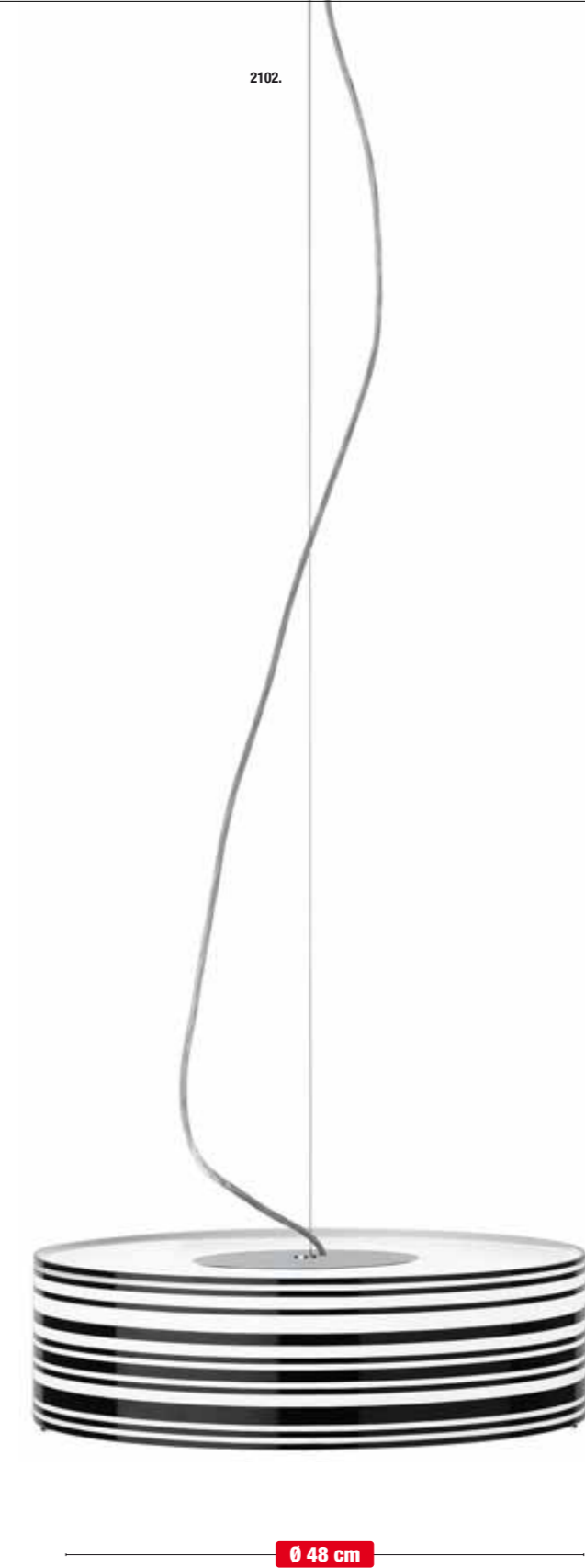

Ø 48 cm

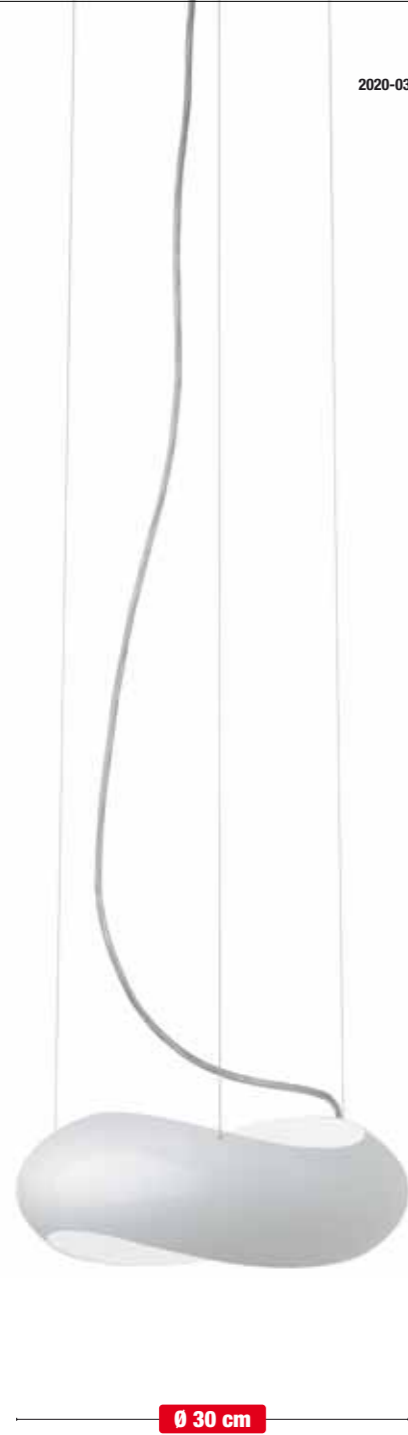

Ø 30 cm



Ø 30 cm



Ø 45 cm



Ø 45 cm

HANGING LAMPS  
COLGANTES

**Infinity**  
Design by Robby Cantarutti.

**2020 / 2021.**  
White lacquer, black lacquer or red lacquer /  
Lacado blanco, lacado negro y lacado rojo.  
Methacrylate diffuser / Difusor de metacrilato.

**2020.**  
GX13 22W Max (T5).

**2021.**  
GX13 60W Max (T5).



2020.



2021.

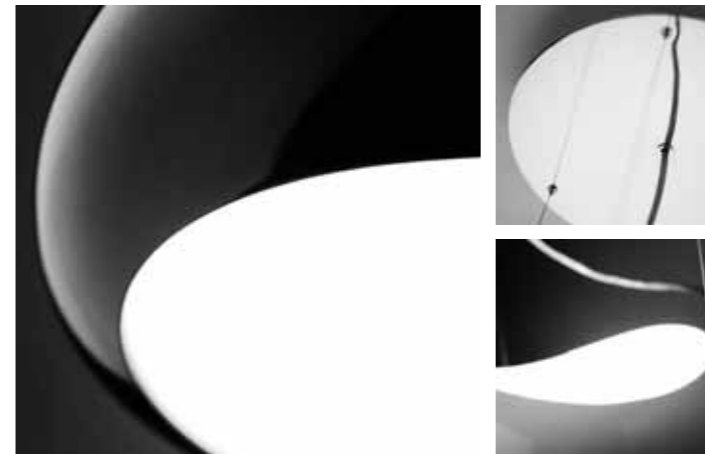

White lacquer / Lacado blanco. Black lacquer / Lacado negro. Red lacquer / Lacado rojo.



HANGING LAMPS  
COLGANTES

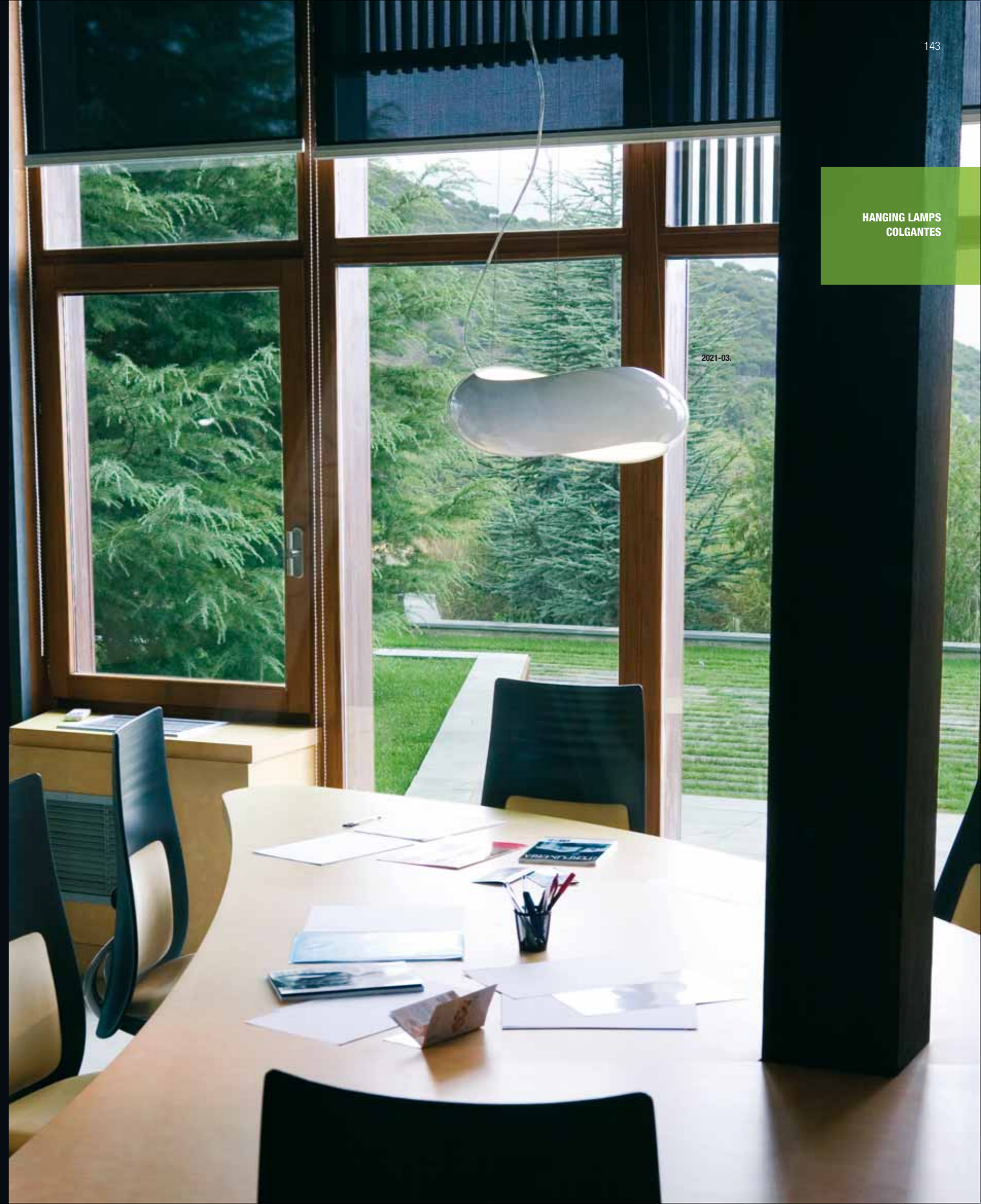

**Slim**

Design by Jordi Vilardell.

**0901 / 0902.**

White lacquer, black lacquer /  
Lacado blanco, lacado negro.  
Borosilicate diffuser / Difusor de borosilicato.  
GY 6,3 (Osram ministar axial) 12V 20W Max.  
☐⊙

0901.

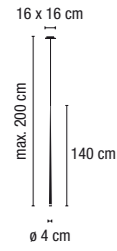

0902.

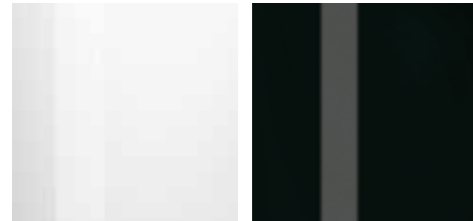
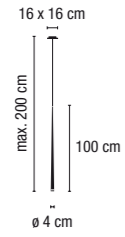

0901-03 / 0902-03. White lacquer / Lacado blanco. 0901-04 / 0902-04. Black lacquer / Lacado negro.

0901.



Ø 4 cm

0902.



Ø 4 cm

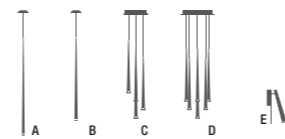

SLIM. Family / Familia  
Pages / Páginas: A-144. B-144. C-148. D-150. E-432.

HANGING LAMPS  
COLGANTES



0902.

**8990.**

Two-hanging lamps  
installation case / Caja anclaje  
de dos colgantes

12,1 cm  
27,3 cm



30 x 2 x 12 cm



1 x 8990  
2 x 0901

**8991.**

Three-hanging lamps  
installation case / Caja anclaje  
de tres colgantes.

12,1 cm  
43,3 cm



46 x 2 x 12 cm



1 x 8991  
3 x 0901

**8992.**

Four-hanging lamps  
installation case / Caja anclaje  
de cuatro colgantes.

28,1 cm  
27,3 cm

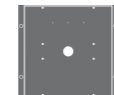

30 x 2 x 28 cm



1 x 8992  
4 x 0901

**Installation.**

For a multiple-base installation, you will need the sufficient quantity of hanging lamp (Ref. 0901 or 0902) and the corresponding case (Ref. 8990, 8991 or 8992).

**Instalación.**

Para instalar bases múltiples, se debe adquirir la cantidad de colgantes necesarios (Ref. 0901 ó 0902) y, adicionalmente la caja base correspondiente (Ref. 8990, 8991 o 8992).

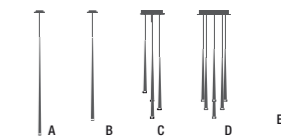

SLIM. Family / Familia  
Pages / Páginas: A-144. B-144. C-148. D-150. E-432.

**Slim**

Design by Jordi Vilardell.

**0903.**

White lacquer, black lacquer /  
Lacado blanco, lacado negro.  
Borosilicate diffuser / Difusor de borosilicato.  
4 x GY 6,3 (Osram ministar axial) 12V 20W Max.  
☐⊕

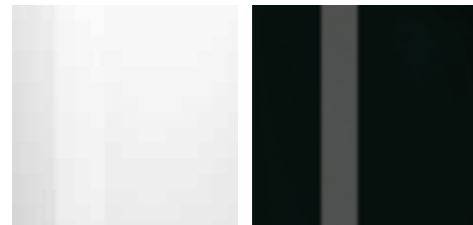
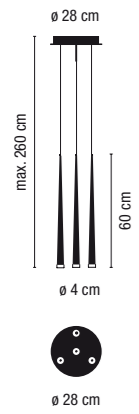

0903-03. White lacquer / Lacado blanco. 0903-04. Black lacquer / Lacado negro.



Ø 4 cm

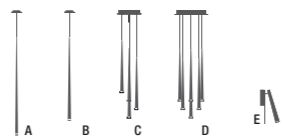

SLIM. Family / Familia  
Pages / Páginas: A-144. B-144. C-148. D-150. E-432.

HANGING LAMPS  
COLGANTES





**Slim**

Design by Jordi Vilardell.

**0904.**

White lacquer, black lacquer /  
Lacado blanco, lacado negro.  
Borosilicate diffuser / Difusor de borosilicato.  
7 x GY 6,3 (Osram ministar axial) 12V 20W Max.  
☐⊙

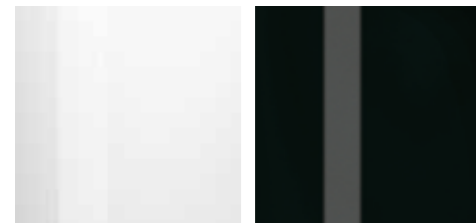
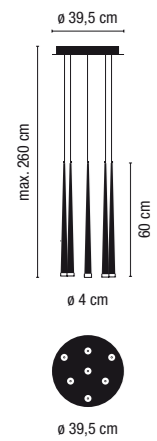

0904-03. White lacquer / Lacado blanco. 0904-04. Black lacquer / Lacado negro.

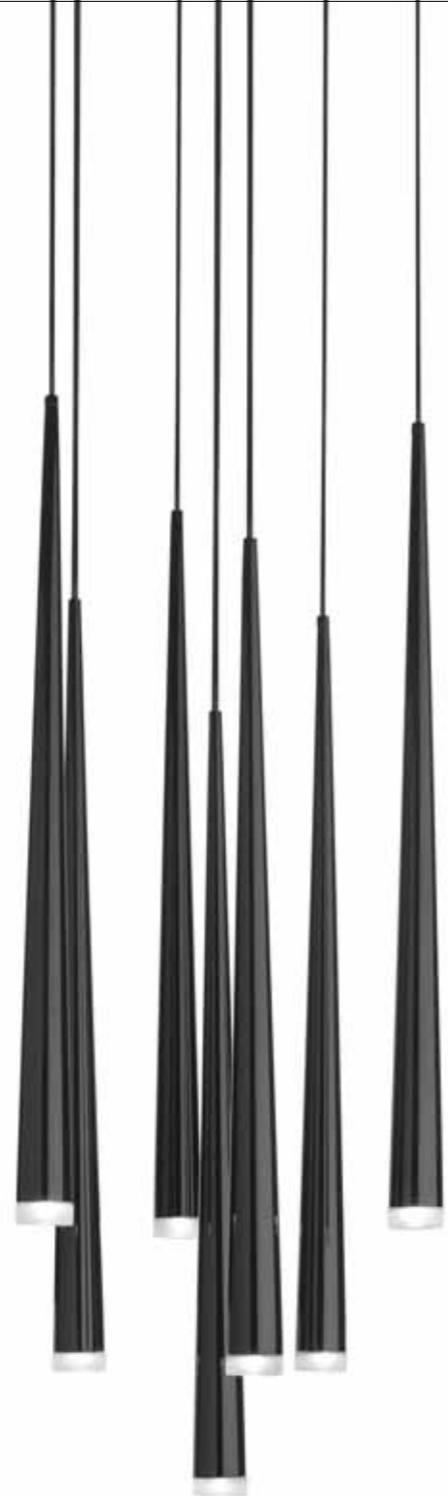
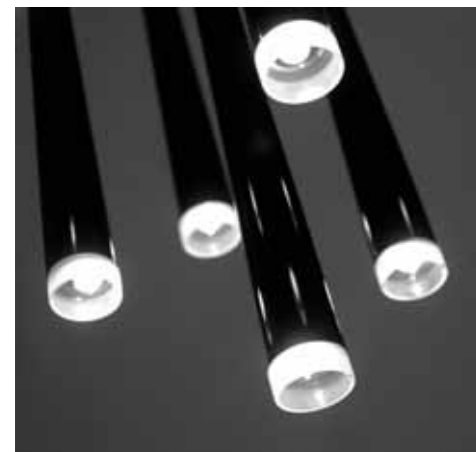

$\varnothing 4 \text{ cm}$

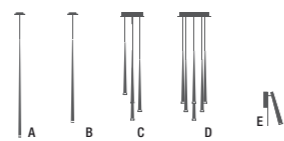

SLIM. Family / Familia  
Pages / Páginas: A-144. B-144. C-148. D-150. E-432.

HANGING LAMPS  
COLGANTES

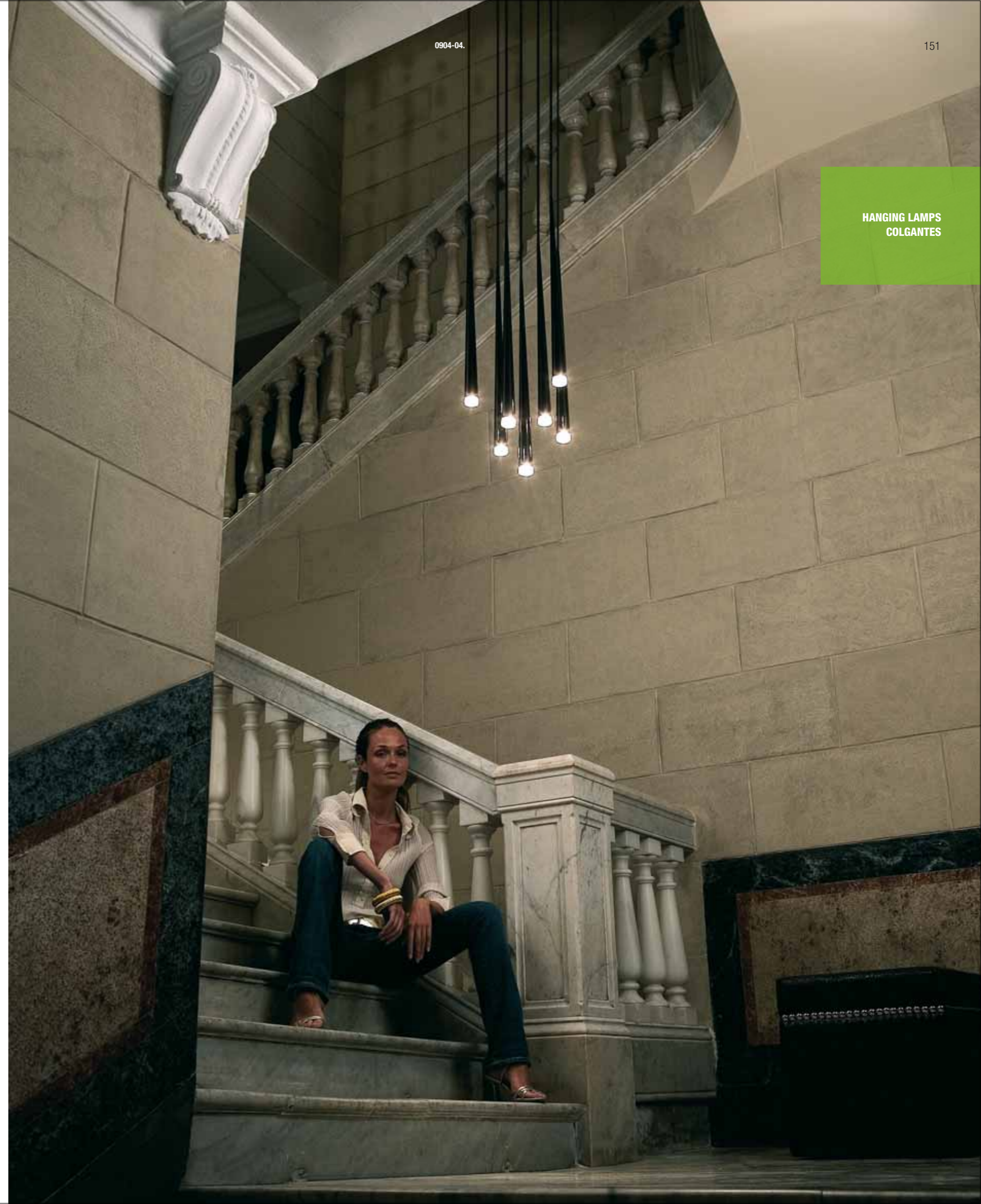



Ø 70 cm

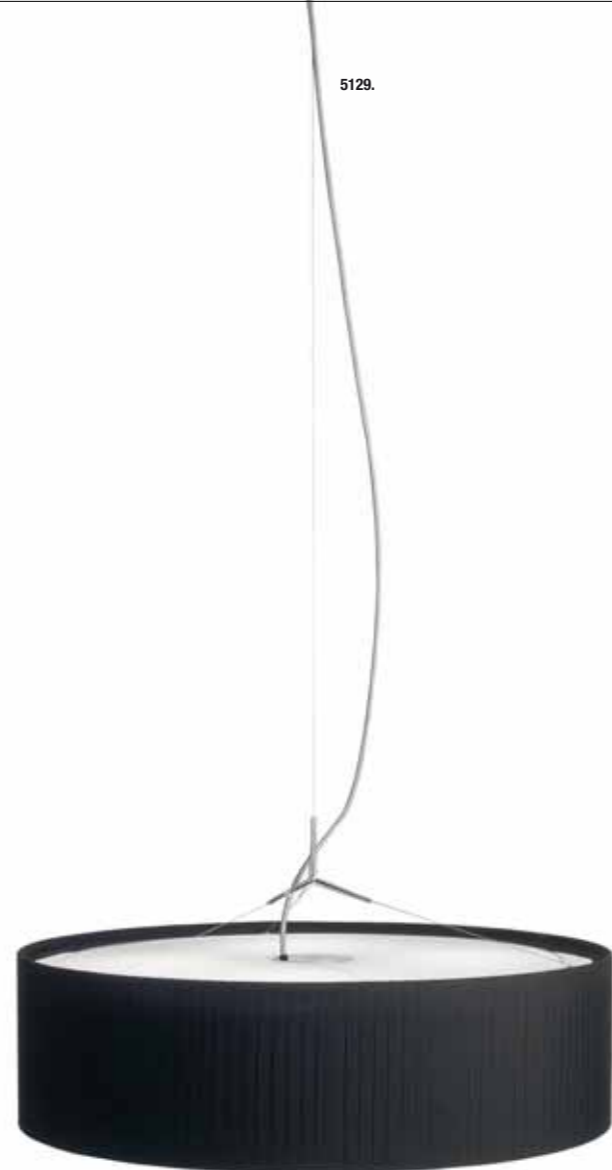

Ø 70 cm



Ø 70 cm

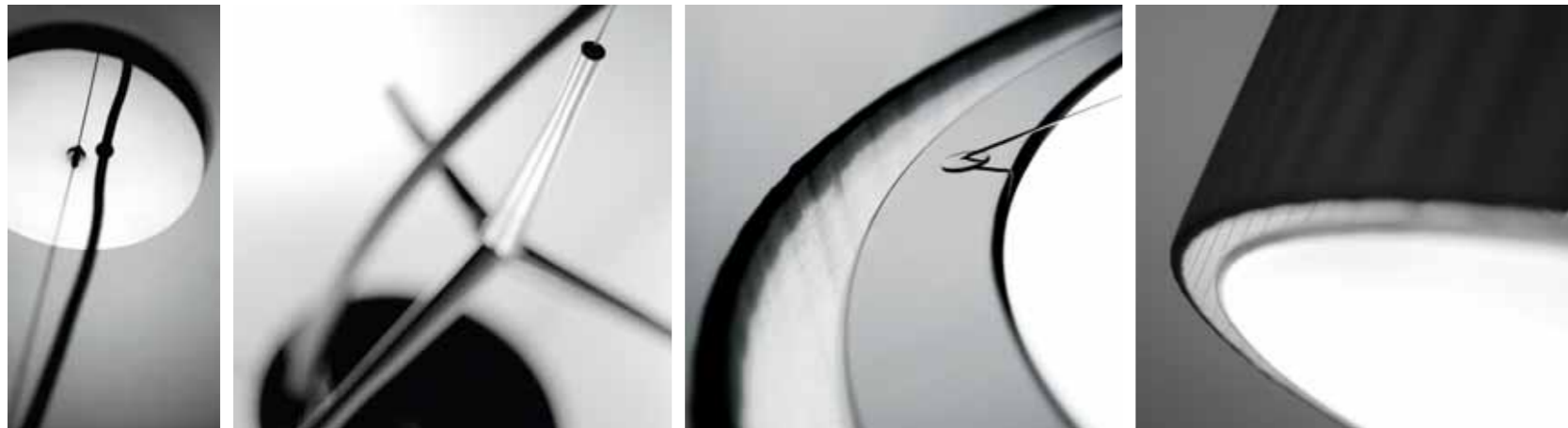

Optical glass on top of the diffuser / Vidrio óptico en la parte superior de la pantalla.  
Methacrylate disc on the bottom of diffuser / Disco de metacrilato en la parte inferior de la pantalla.

## Plis

Design by G. Bernal & Associats.

### 5124 / 5125 / 5126 / 5128 / 5129 / 5130.

Chrome / Cromo.

5124 / 5128: Cream cotton ribbon diffuser / Difusor de cinta de algodón color crudo.

5125 / 5129: Black cotton ribbon diffuser / Difusor de cinta de algodón negro.

5126 / 5130: Red cotton ribbon diffuser / Difusor de cinta de algodón rojo.

Difuser / Difusor Ø 55 cm: 3 x E27 Mate 100W Max.



Difuser / Difusor Ø 70 cm: 4 x E27 Mate 150W Max.



### 5124 / 5125 / 5126.

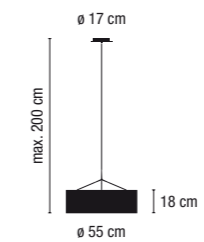

### 5128 / 5129 / 5130.

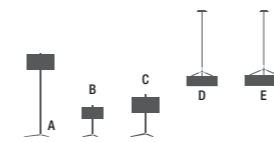
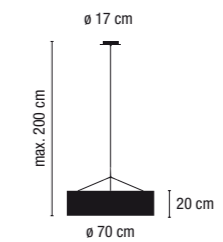

PLIS. Family / Familia

Pages / Páginas: A-26. B-99. C-99. D-152. E-152.

HANGING LAMPS  
COLGANTES



5129.



Ø 50 cm



1380-03 / 1381-03.  
White lacquer / Lacado blanco.

1380-04 / 1381-04.  
Black lacquer / Lacado negro.

1380-30 / 1381-30.  
Matt nickel / Niquel mate.

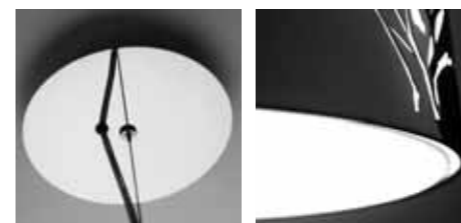

### Nature

Design by Diego Fortunato.

#### 1380 / 1381.

White lacquer, black lacquer or matt nickel /  
Lacado negro, lacado blanco y niquel mate.  
Metal diffuser / Difusor metálico.

1380: 4 x E14 Esférica Mate 60W Max.

1381: 4 x E27 Mate 230V 60W Max.

1380.

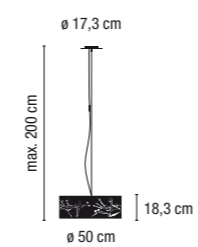

1381.

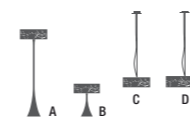
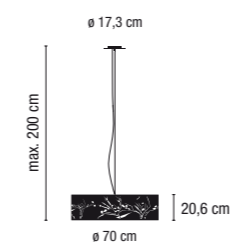

NATURE. Family / Familia

Pages / Páginas: A-24. B-79. C-157. D-157.



Ø 70 cm



Optical glass on top and white polymer disc on the bottom / Black glass disc / Vidrio óptico superior y disco polimero blanco inferior. / Disco de vidrio negro.

**Forest**  
Design by Ramos & Bassols.

- 5290 / 5291.**  
Chrome / Cromo.  
Wengue diffuser / Difusor de madera Wenqué.  
**5290:** 5 x E14 Esférica Mate 60W Max.  
○  
**5291:** 4 x E14 Esférica Mate 60W Max.  
○

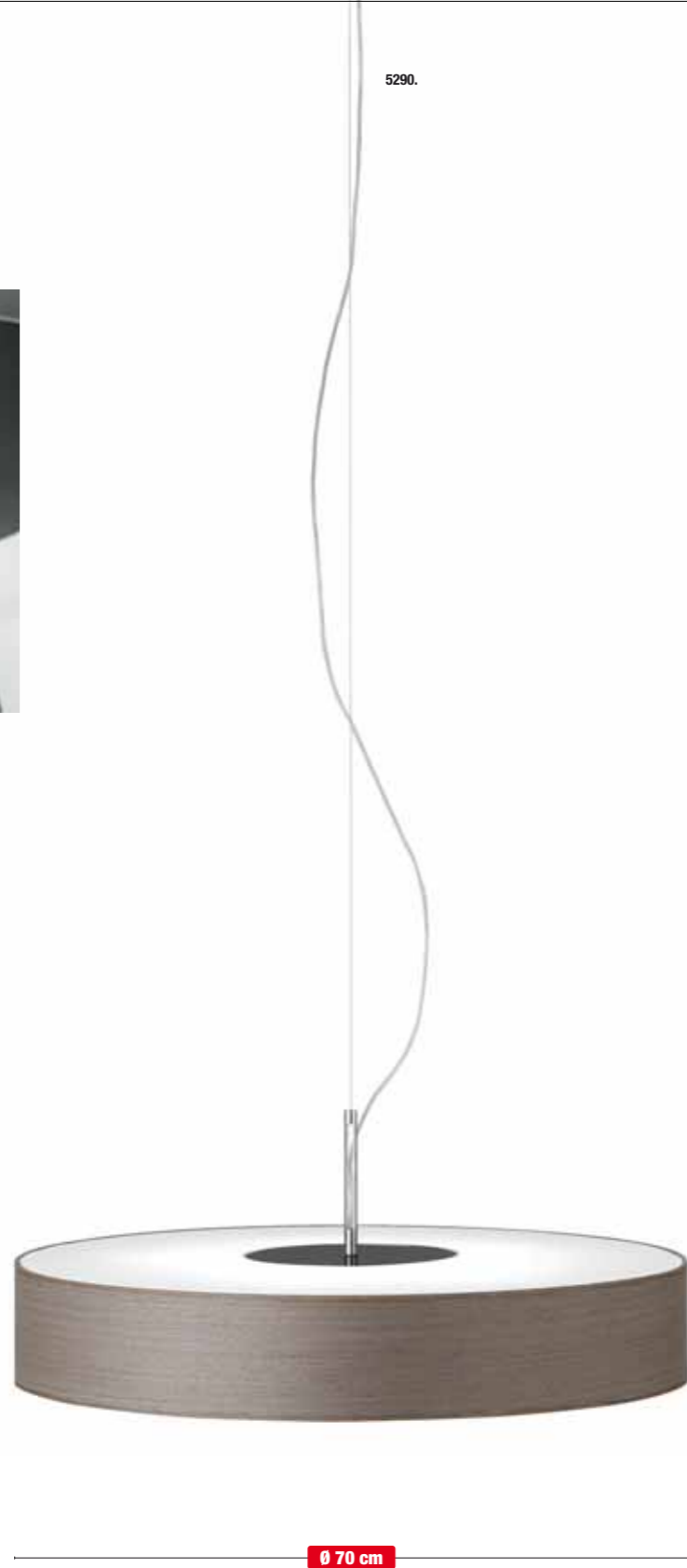
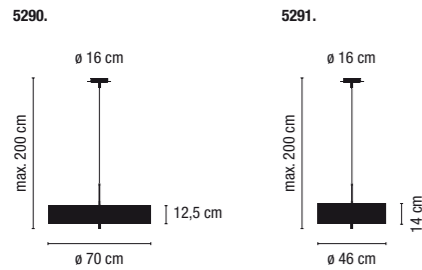

HANGING LAMPS  
COLGANTES

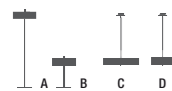

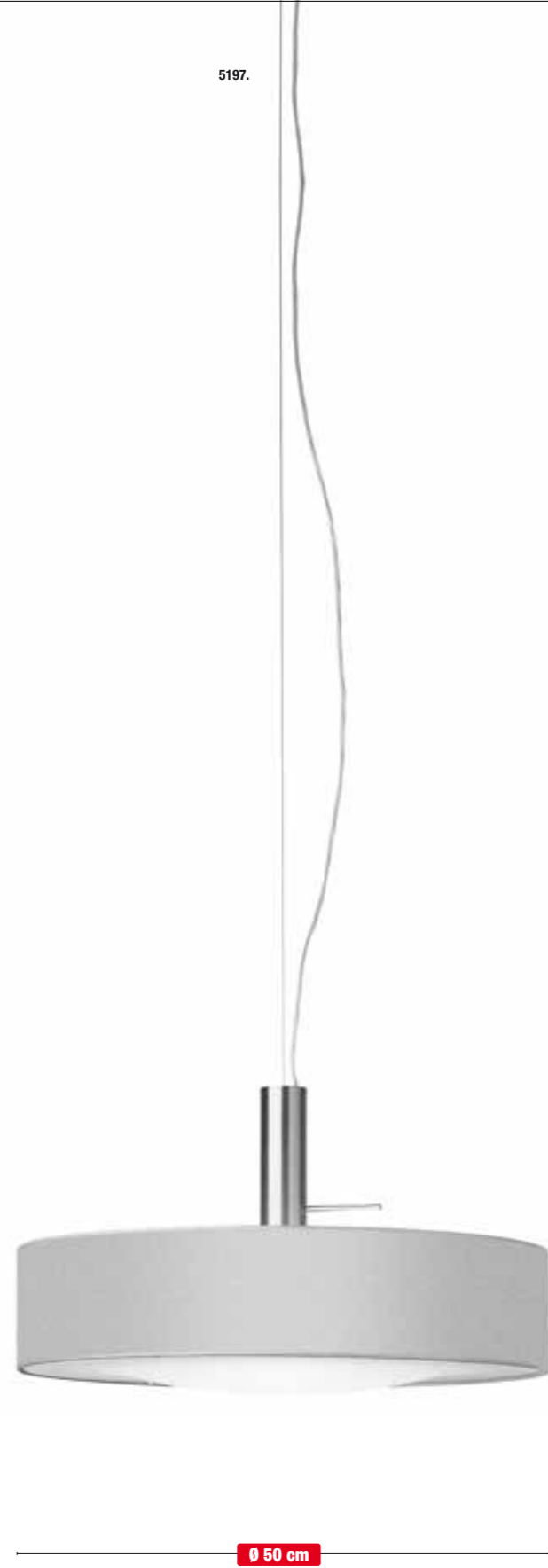

Ø 50 cm

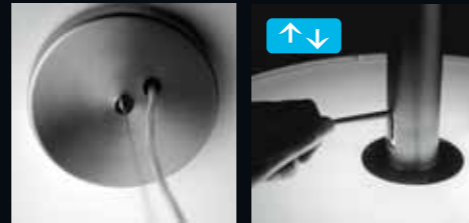

Two different positions:  
**A**- General diffusion **B**- Downward light diffusion.  
 Dos posiciones:  
**A**- Difusión general. **B**- Difusión sólo hacia abajo

### Duplo

Design by Jordi Vilardell.

**5196 / 5197.**  
 Matt nickel / Níquel mate.

**5196.** Pleated-fabric and optical-glass diffuser /  
 Difusor de tejido plisado y vidrio óptico.

**5197.** Metal-weft and optical-glass diffuser /  
 Difusor de trama metálica y vidrio óptico.  
 Halógena Tubular E27 230V 250W Max.

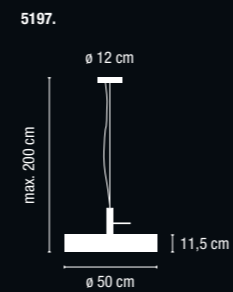
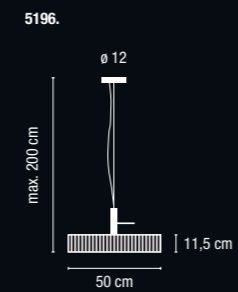

DUPL0.Family / Familia  
 Pages / Páginas: A-50, B-146.



5196.



HANGING LAMPS  
COLGANTES

**Moving**  
Design by Jordi Vilardell.

**5167 / 5169.**  
Matt nickel / Niquel mate.  
**5167:** Opal triplex blown-glass diffuser / Difusor de vidrio soplado opal triplex.  
**5169:** Steel and glass diffuser / Difusor de acero y vidrio.  
E27 Mate 150W Max.

**5164 / 5166.**  
Matt nickel / Niquel mate.  
**5164:** Steel and glass diffuser / Difusor de acero y vidrio.  
**5166:** Opal triplex blown-glass diffuser / Difusor de vidrio soplado opal triplex.  
2 x E27 Mate 150W Max.

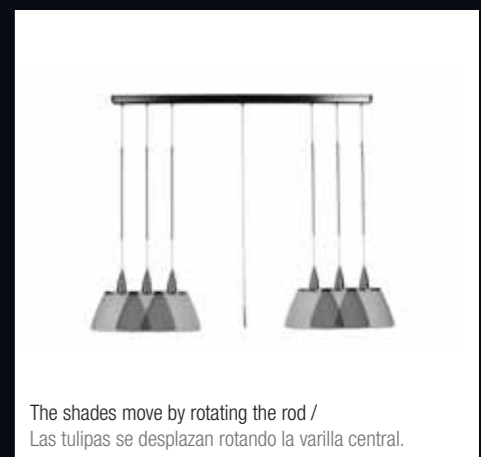
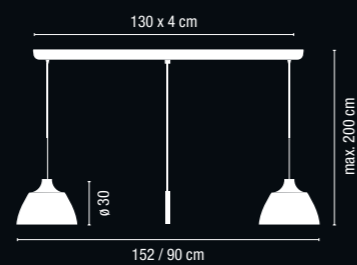
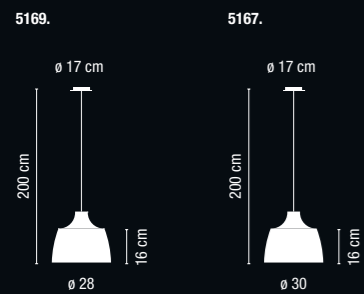

The central rod can be easily removed /  
La varilla central se puede quitar fácilmente.

The shades move by rotating the rod /  
Las tulipas se desplazan rotando la varilla central.

5161.



182 x 110 cm



HANGING LAMPS  
COLGANTES

**Moving**

Design by Jordi Vilardell.

**5161 / 5163.**

Matt nickel / Niquel mate.

**5161:** Steel and glass diffuser / Difusor de acero y vidrio.

**5163:** Opal triplex blown-glass diffuser / Difusor de vidrio soplado opal triplex.  
3 x E27 Mate 150W Max.



**5163.**  
Opal triplex blown-glass  
diffuser / Difusor de vidrio  
soplado opal triplex.



**5161.**  
Steel and glass diffuser /  
Difusor de acero y vidrio.

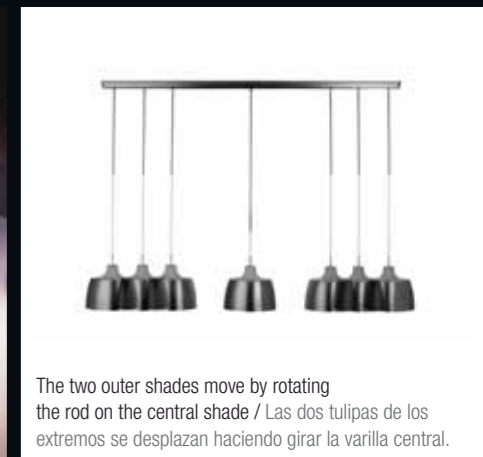
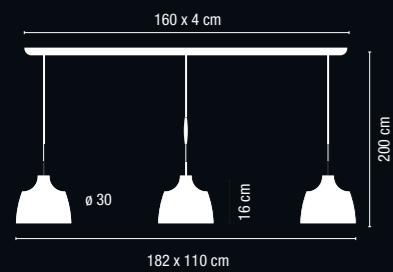

The two outer shades move by rotating  
the rod on the central shade / Las dos tulipas de los  
extremos se desplazan haciendo girar la varilla central.



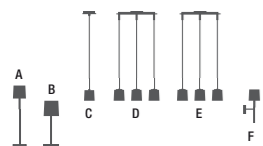

TULIP, Family / Familia  
 Pages / Páginas: A-106. B-106. C-166. D-166. E-166. F-422.



12 cm

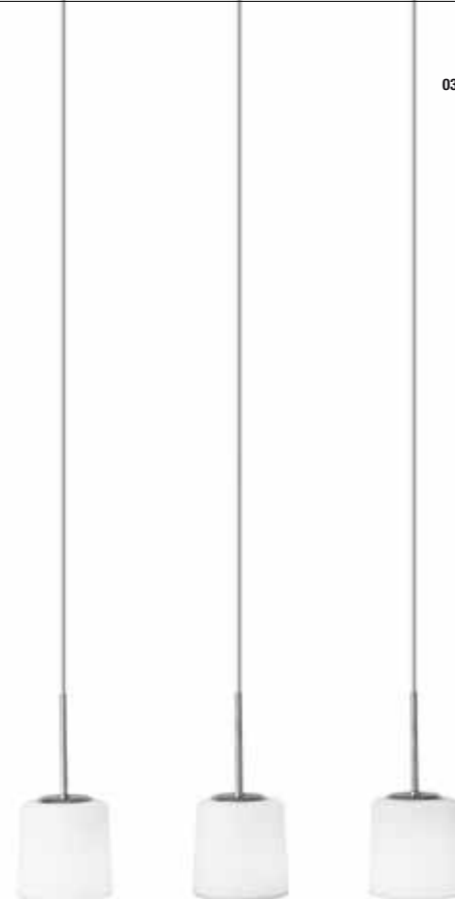

51 cm

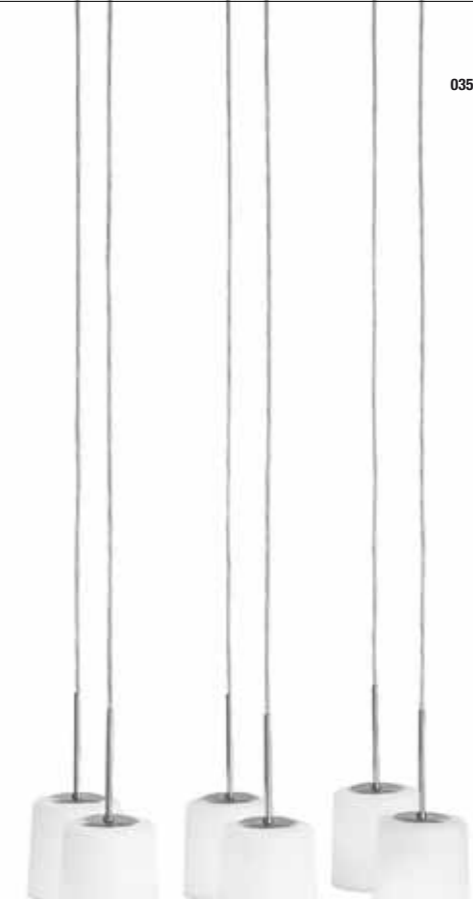

51 cm

HANGING LAMPS  
 COLGANTES

**Tulip**

Design by Lièvore, Altherr, Molina.

**0355 / 0356 / 0362.**

Chrome / Cromo.  
 Matt opal triplex blown-glass diffuser /  
 Difusor de vidrio soplado opal mate triplex.  
**0355:** E14 Esférica Mate 60W Max.  
**0356:** 6 x E14 Esférica Mate 60W Max.  
**0362:** 3 x E14 Esférica Mate 60W Max.



0355.  
 1 shade / 1 tulipa.  
 Chrome / Cromo.



0362.  
 3 shades / 3 tulipas.  
 White / Blanco.



0356.  
 6 shades / 6 tulipas.  
 White / Blanco.

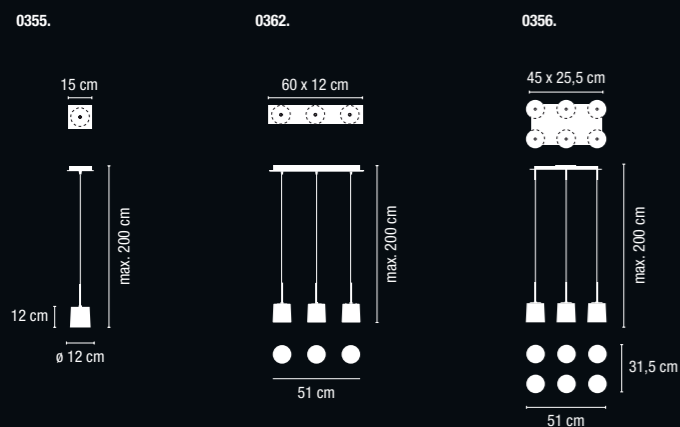

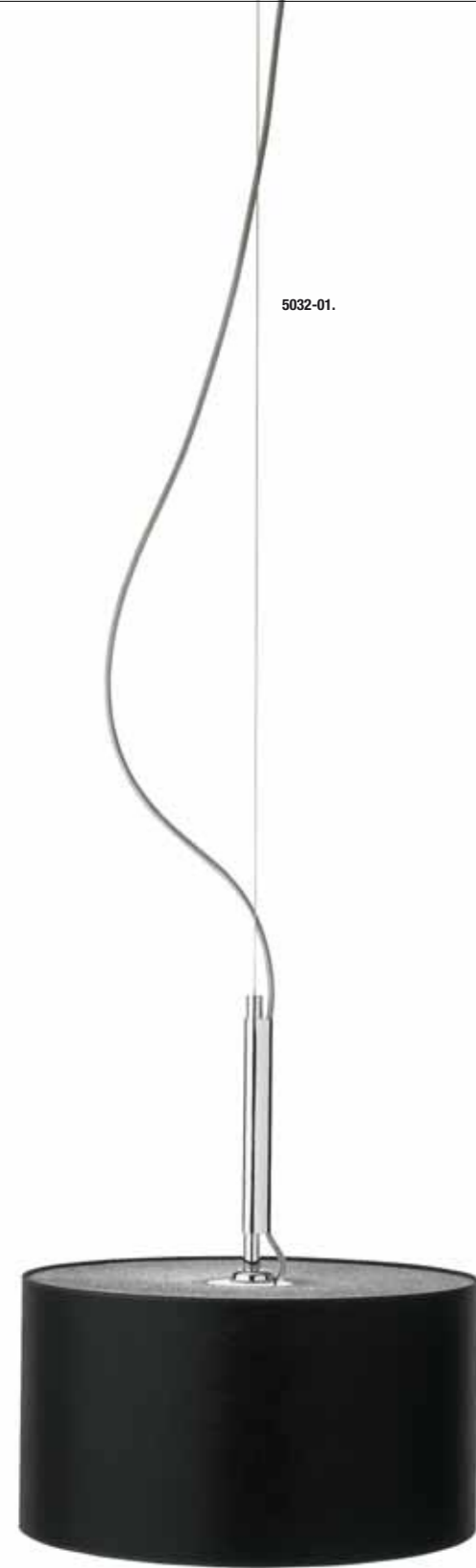

5032-01.

Ø 42 cm



**Mast**

Design by Gemma Bernal and Ramón Isern.

**5032-30.**

Matt nickel / Níquel mate.  
White polymer diffuser / Difusor de polímero blanco.  
E27 Mate 150W Max.



**5032-01.**

Chrome / Cromo.  
Black chinz diffuser / Difusor de Chinz negro.  
E27 Mate 150W Max.

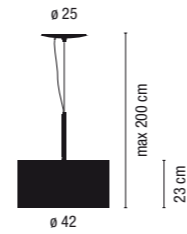

**5032-30.**  
Matt nickel / Níquel mate.  
White polymer diffuser /  
Difusor de polímero blanco.

**5032-01.**  
Chrome / Cromo.  
Black chinz diffuser /  
Difusor de Chinz negro.

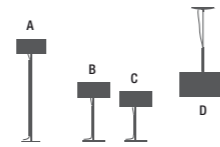

MAST. Family / Familia  
Pages / Páginas: A-58. B-118. C-118. D-168.





1406.

**Iso**  
Design by Lievore, Altherr, Molina.

**1405.**  
Chrome / Cromo.  
Matt opal triplex blown-glass diffuser /  
Difusor de vidrio soplado opal mate triplex.  
Halógena Tubular E27 230V 250W Max.



**Mini**

**1406.**  
Chrome / Cromo.  
Opal triplex blown-glass diffuser /  
Difusor de vidrio soplado opal triplex.  
G9 230V 75W Max.

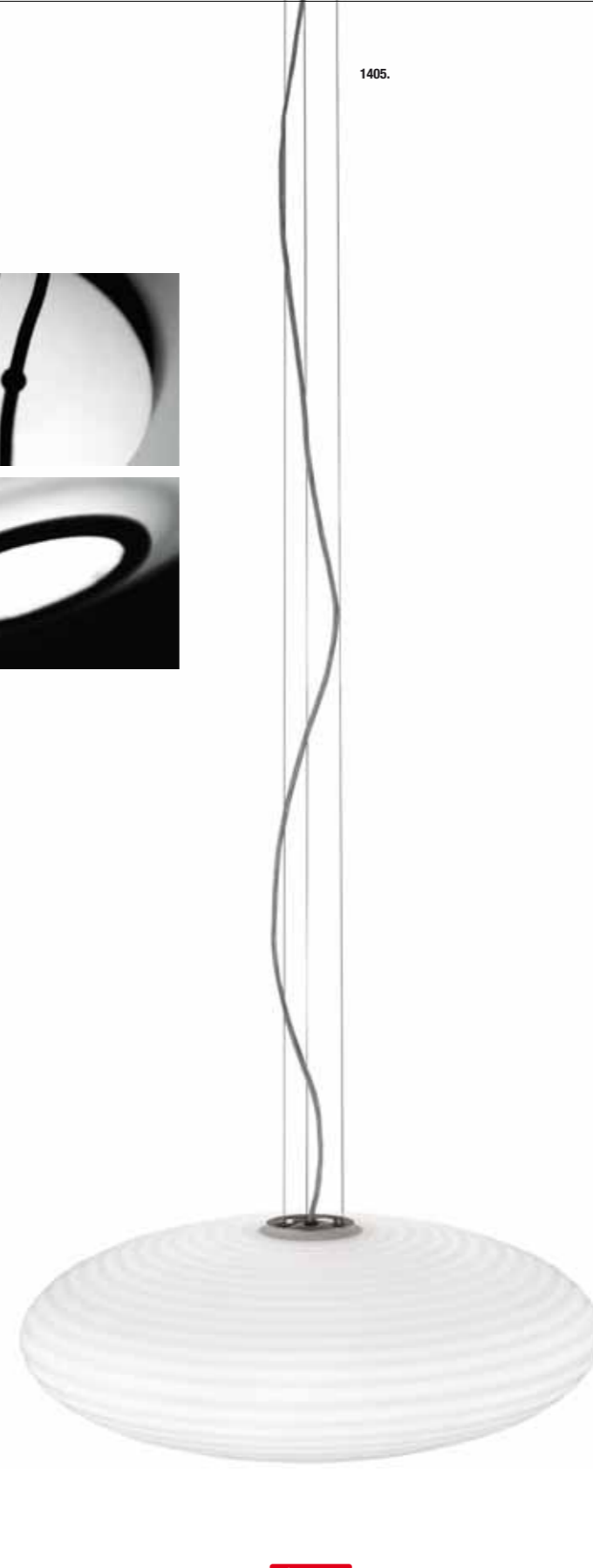
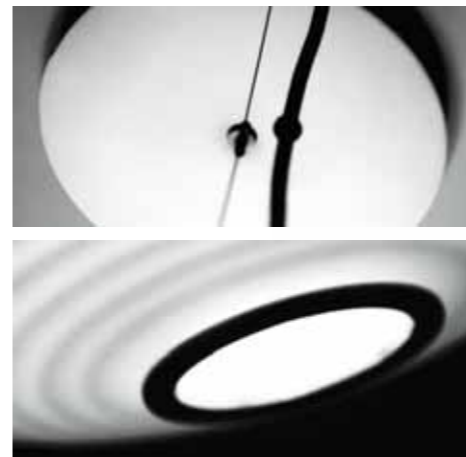
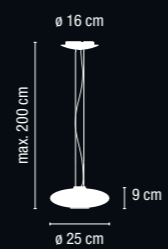

Ø 52 cm



Ø 25 cm

mini

HANGING LAMPS  
COLGANTES

5330.

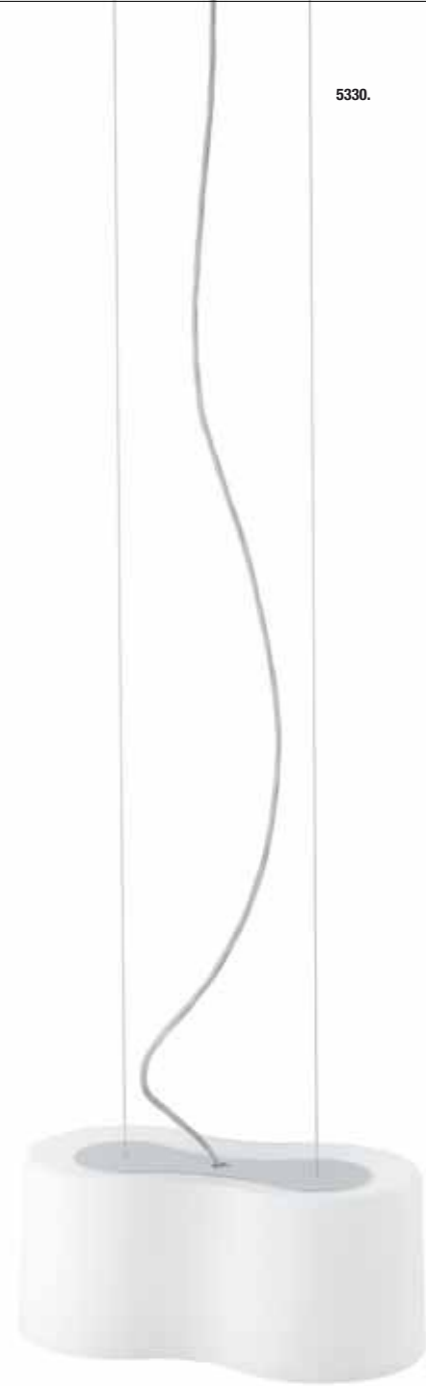

36 x 18 cm

5331.



36 x 18 cm

5332.



36 x 18 cm

5333.

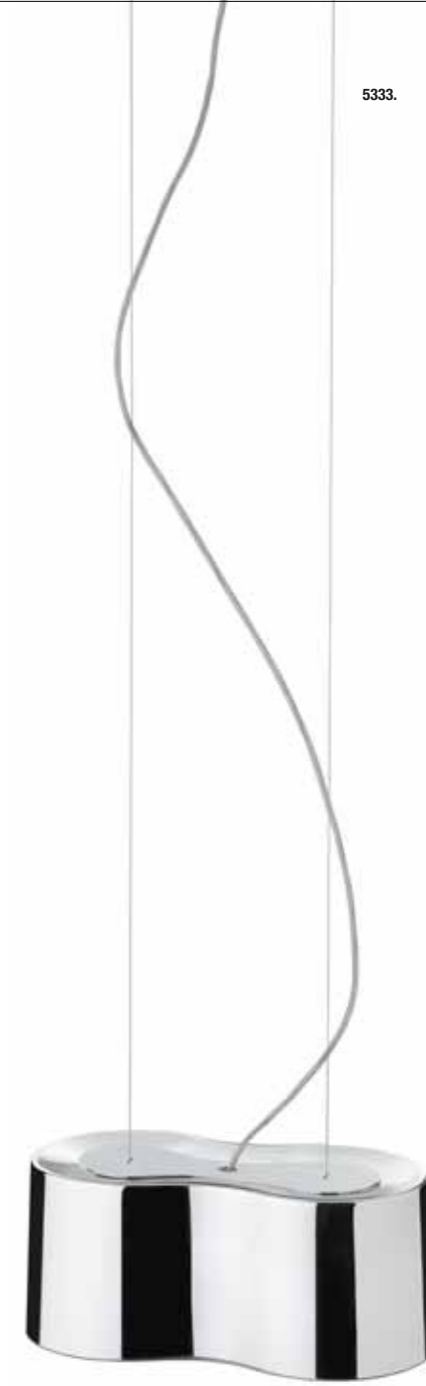

36 x 18 cm

HANGING LAMPS  
COLGANTES



**Eight**  
Design by Ramos & Bassols.

**5330 / 5331 / 5332 / 5333.**  
Opal glass, black glass, red glass or mirror glass /  
Vidrio opal, vidrio negro, vidrio rojo y vidrio espejo.  
Opal triplex blown-glass diffuser /  
Difusor de vidrio soplado opal triplex.  
2 x E27 60W.



EIGHT. Family / Familia  
Pages / Páginas: A-172. B-174. C-177.

5335.  
Opal glass / Vidrio opal.

5336.  
Black glass / Vidrio negro.

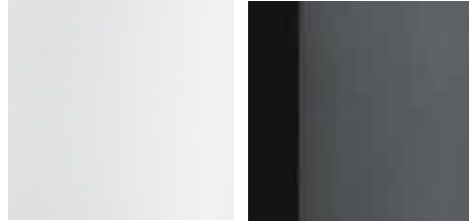

5337.  
Red glass / Vidrio rojo.

5338.  
Mirror glass / Vidrio espejo.

**Eight**  
Design by Ramos & Bassols.

**5335 / 5336 / 5337 / 5338.**  
Opal glass, black glass, red glass or mirror glass /  
Vidrio opal, vidrio negro, vidrio rojo y vidrio espejo.  
Opal triplex blown-glass diffuser /  
Difusor de vidrio soplado opal triplex.  
6 x E27 60W.

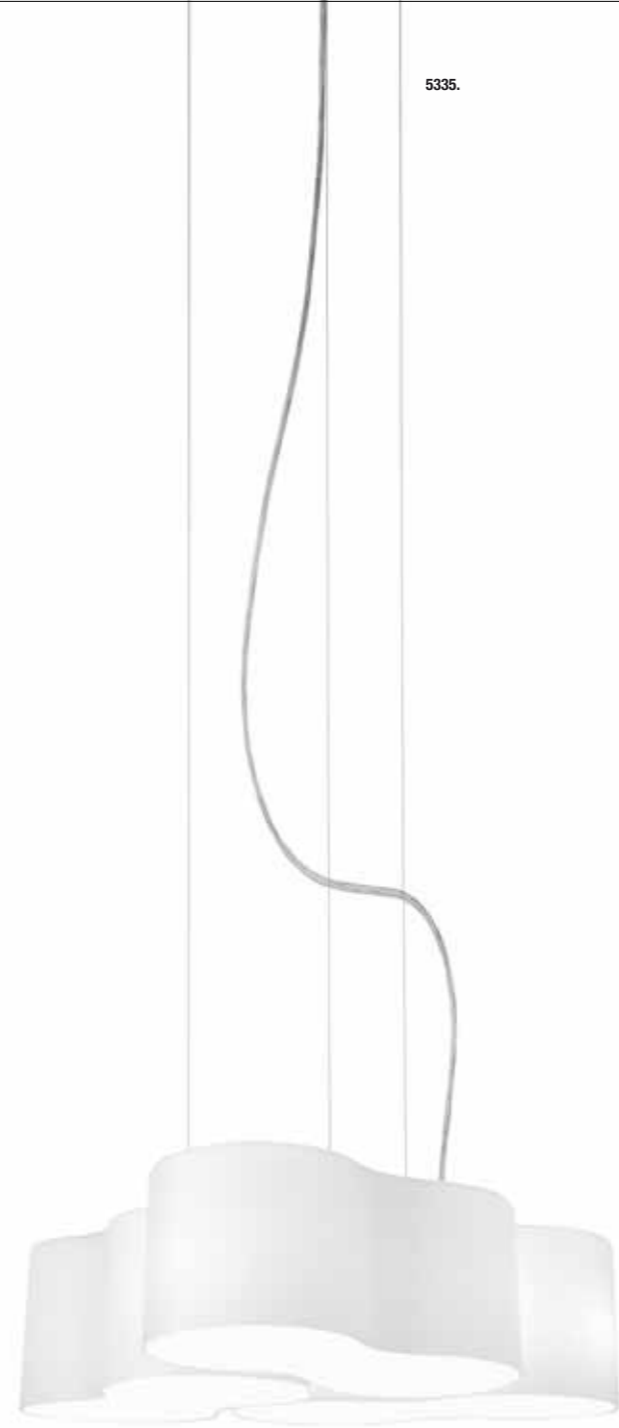
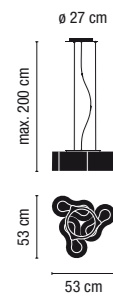

HANGING LAMPS  
COLGANTES

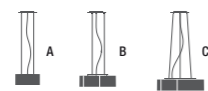
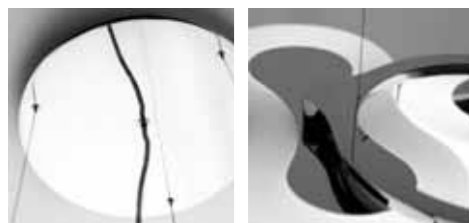

EIGHT. Family / Familia  
Pages / Páginas: A-172. B-174. C-177.



HANGING LAMPS  
COLGANTES

5340.  
Opal glass / Vidrio opal.



5341.  
Black glass / Vidrio negro.



5342.  
Red glass / Vidrio rojo.



5343.  
Mirror glass / Vidrio espejo.

**Eight**  
Design by Ramos & Bassols.

**5340 / 5341 / 5342 / 5343.**  
Opal glass, black glass, red glass or mirror glass /  
Vidrio opal, vidrio negro, vidrio rojo y vidrio espejo.  
Opal triplex blown-glass diffuser /  
Difusor de vidrio soplado opal triplex.  
10 x E27 60W.

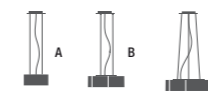
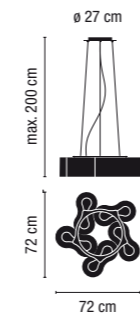

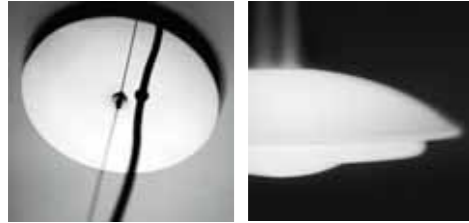

**Lotto**

Design by Proli Diffusion Studio.

**1195 / 1185.**

Matt nickel / Níquel mate.

Optical glass diffuser / Difusor de vidrio óptico.

**1195:** Halógena Tubular E27 230V 250W Max.

**1185:** G9 230V 40W Max. (OSRAM HALOPIN).



1195.

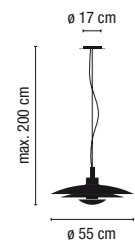

1185.

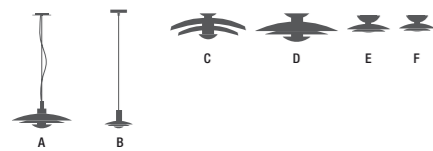
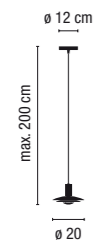

LOTTO. Family / Familia

Pages / Páginas: A-178. B-178. C-269. D-269. E-269. F-269.

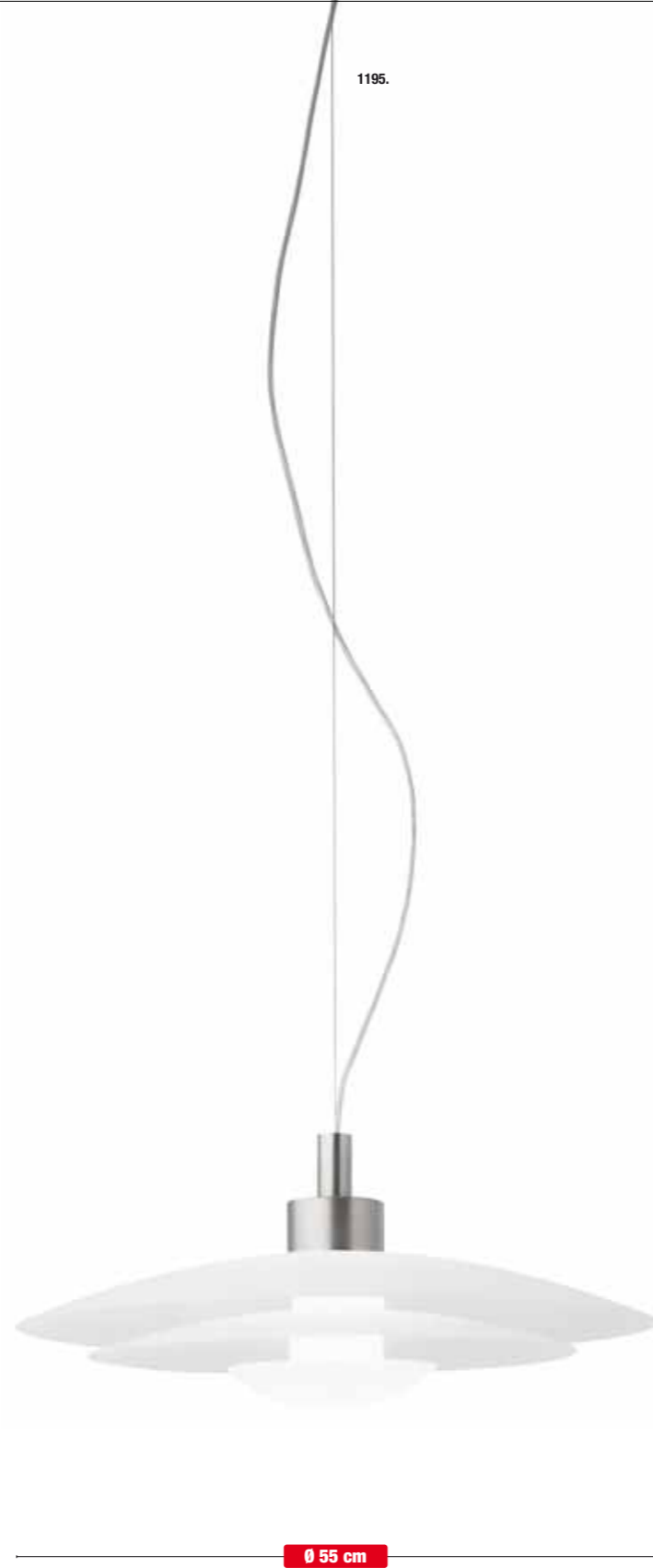

HANGING LAMPS  
COLGANTES

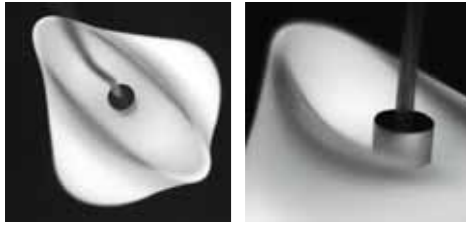

Mini

**Kaos**  
Design by X. Claramunt and M. de Mas.

**1459.**  
Matt opal triplex blown-glass diffuser /  
Difusor de vidrio soplado opal triplex mate.  
G9 230V 75W Max. (OSRAM HALOPIN).

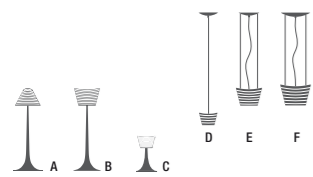
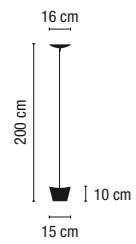

KAOS. Family / Familia  
Pages / Páginas: A-50. B-50. C-102. D-180. E-180. F-180.

1459.



15 cm

HANGING LAMPS  
COLGANTES



**1460 / 1465.**  
Porcelain canopy /  
Florón de porcelana.

**Kaos**  
Design by X. Claramunt and M. de Mas.

**1460 / 1465.**  
Matt opal triplex blown-glass diffuser /  
Difusor de vidrio soplado opal mate triplex.  
R7s 117mm. 230V 200W Max.

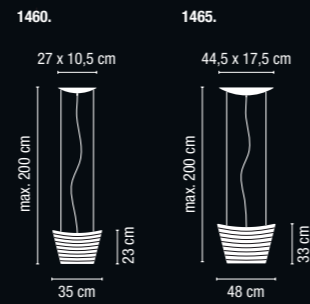

1465.



1460.





HANGING LAMPS  
COLGANTES



**Nobel**  
Design by Österlund design development (ODD).

**2060 / 2061 / 2062.**  
 Chrome, matt nickel / Cromo, níquel mate.  
**2060 / 2061:** Borosilicate diffuser / Difusor de borosilicato.  
**2062:** Blown-glass diffuser / Difusor de vidrio soplado  
**2060 / 2061:** Halógena Tubular E27 230V 250W Max.  
**2062:** G9 230V 75W Max. (OSRAM HALOPIN).

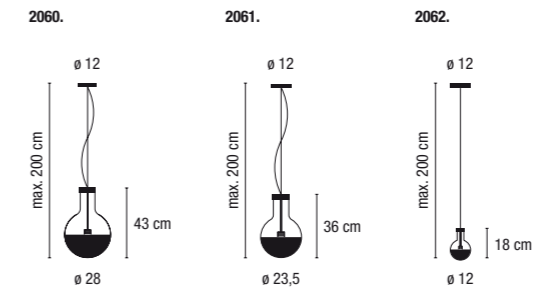



Matt opal triplex blown-glass /  
Vidrio soplado opal mate triplex.

**Nadia**

Design by G. Bernal and Associats.

**5226 / 5228.**

Chrome / Cromo.  
Matt opal triplex blown-glass diffuser /  
Difusor de vidrio soplado opal mate triplex.

**5226:** E27 Mate 100W Max.  
**5228:** E27 Mate 150W Max.

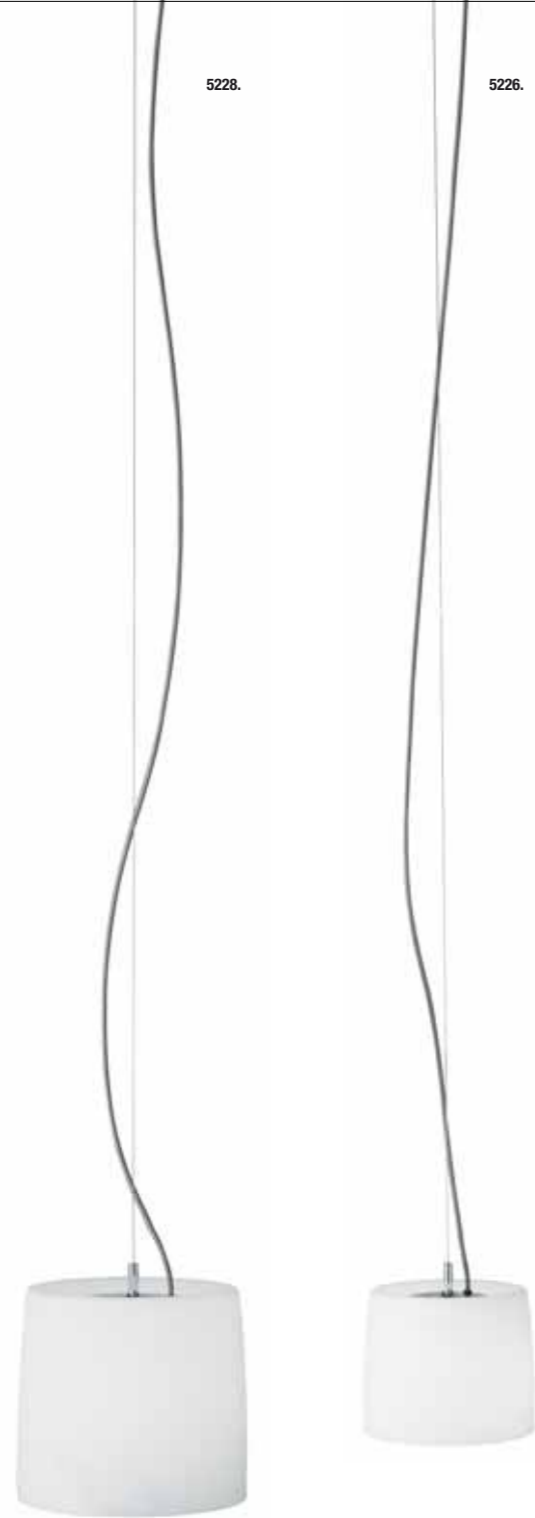
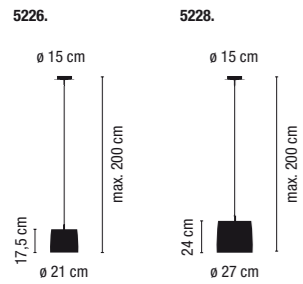

Ø 27 cm

Ø 21 cm

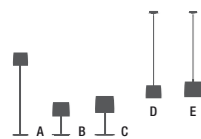

HANGING LAMPS  
COLGANTES





Ø 25 cm

Ø 25 cm

Ø 25 cm

Ø 25 cm

Ø 25 cm

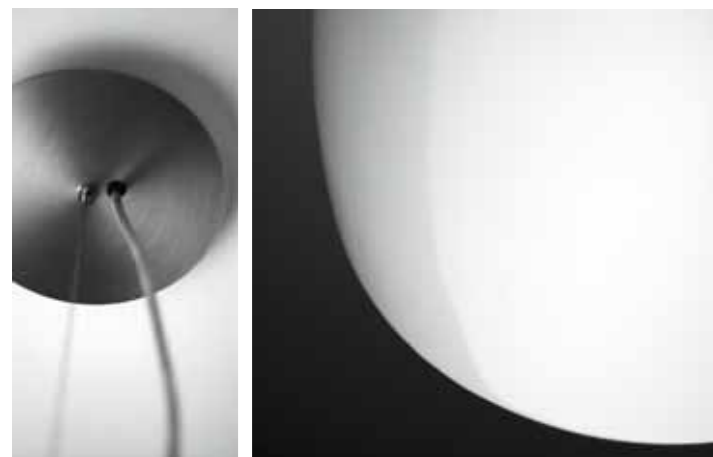

**Jazz**

Design by Diego Fortunato.

**1335.**

White lacquer, black lacquer, red lacquer, gold finish or silver finish /  
Lacado blanco, lacado negro, lacado rojo, acabado oro, acabado plata.  
Rigid high-density resin / Resina rígida de alta densidad.  
E27 Par Halógena 230V 100W Max.



E27 30W (Osram Dulux EL).



A escoger una de las dos bombillas /  
Please, choose one of both mentioned bulbs.

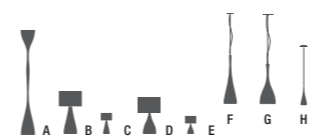
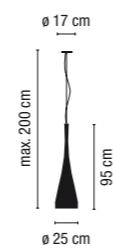

JAZZ. Family / Familia  
Pages / Páginas: A-19. B-81. C-89. D-85. E-89. F-186. G-188.  
H-190. I-190.





Ø 26 cm

1336-03.  
White lacquer / Lacado blanco.



1336-49.  
Silver finish / Acabado plata.

1336-04.  
Black lacquer / Lacado negro.



1336-51.  
Gold finish / Acabado oro.

1336-06.  
Red lacquer / Lacado rojo.



**Jazz**  
Design by Diego Fortunato.

**1336.**  
White lacquer, black lacquer, red lacquer,  
gold finish or silver finish /  
Lacado blanco, lacado negro, lacado rojo,  
acabado oro, acabado plata.  
Rigid high-density resin / Resina rígida alta densidad.  
E27 Par Halógena 230V 100W Max.

E27 30W (Osram Dulux EL)

A escoger una de las dos bombillas /  
Please, choose one of both mentioned bulbs.

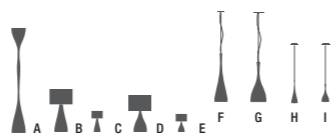
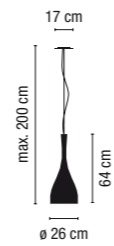

JAZZ. Family / Familia  
Pages / Páginas: A-19. B-81. C-89. D-85. E-89. F-186. G-188. H-190. I-190.



HANGING LAMPS  
COLGANTES

### Mini Jazz

Design by Diego Fortunato.

#### 1337 / 1338.

White lacquer, black lacquer or red lacquer /

Lacado blanco, lacado negro o lacado rojo.

Rigid high-density resin / Resina rígida de alta densidad.

E27 Par Halógena 230V 75W Max.



1337.

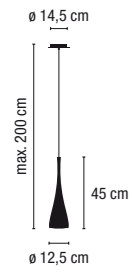

1338.

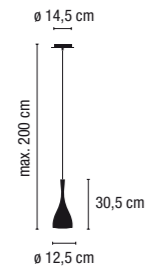

1337-03.



1337-04.



Ø 12,5 cm

1338-06.



Ø 12,5 cm

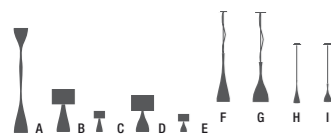

JAZZ. Family / Familia

Pages / Páginas: A-19. B-81. C-89. D-85. E-89. F-186. G-188. H-190. I-190.

HANGING LAMPS  
COLGANTES



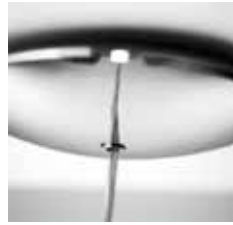

**Join**  
Jordi Vilardell.

**5070.**  
Borosilicate glass /  
Vidrio de borosilicato.  
G9 230V 60W Max. (OSRAM HALOPIN).  
☛

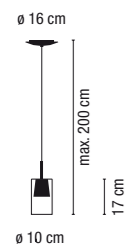

**Ø 10 cm**

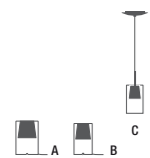

JOIN. Family / Familia  
Pages / Páginas: A-92. B-92. C-192.

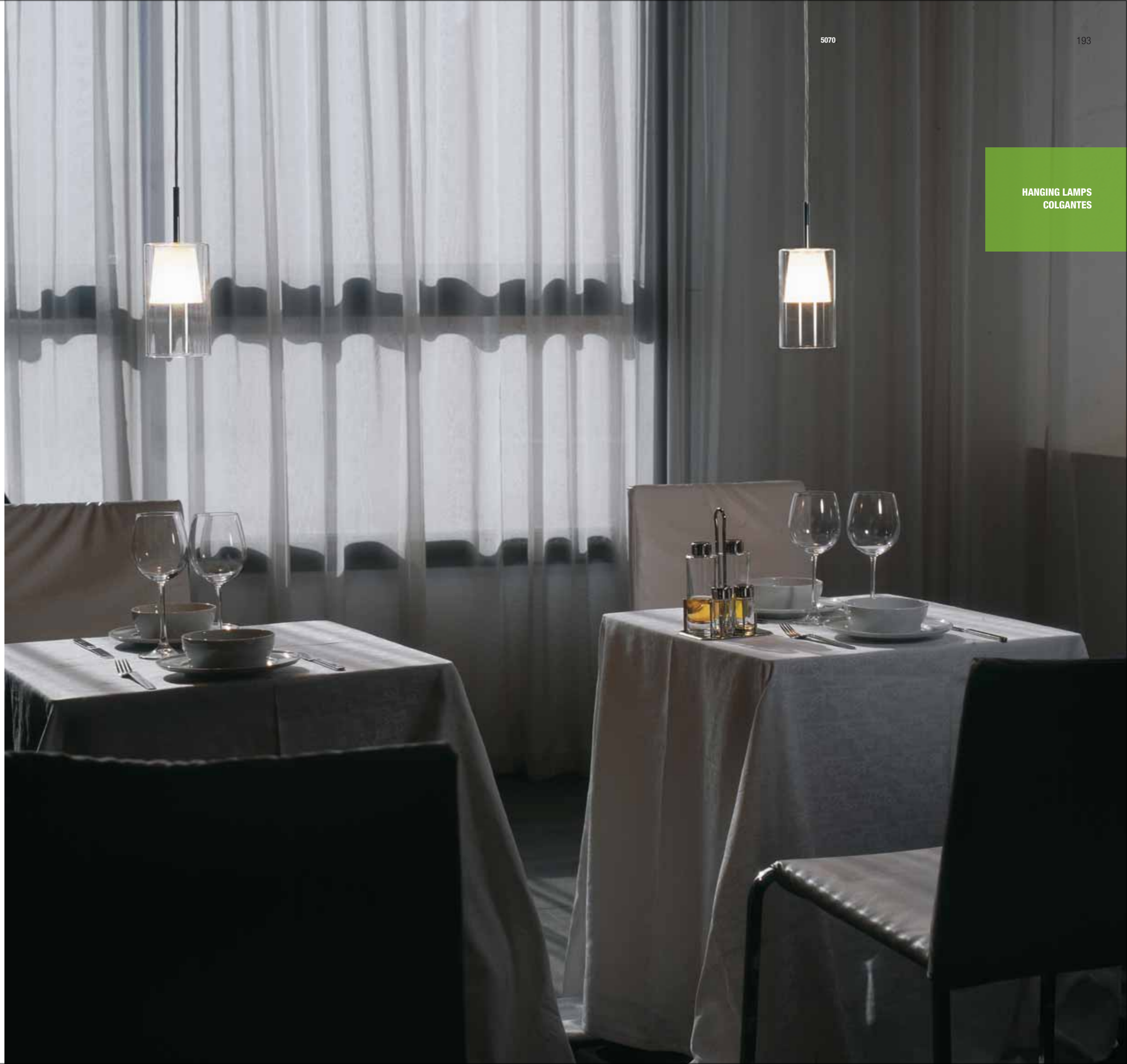

**HANGING LAMPS  
COLGANTES**

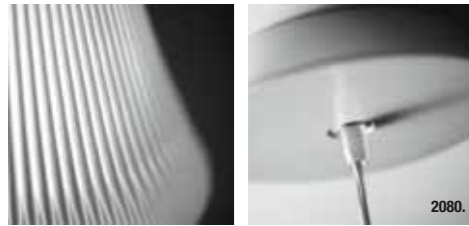

Porcelain / Porcelana



Ø 17 cm

**Glenn**  
Design by Jordi Vilardell.

**2080 / 2081.**  
Porcelain diffuser / Difusor de porcelana.

**2080:** E27 Mate 150W Max.

**2081:** 3 x E27 Mate 150W Max.

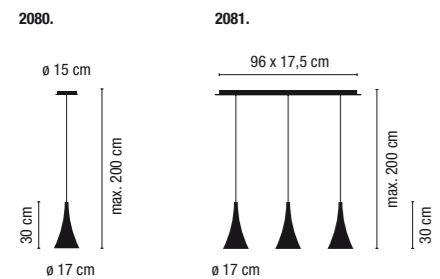

2081.

**HANGING LAMPS**  
**COLGANTES**



2080.

**Sixties**

Design by Margarita Viarnés.

**8950.**

Chrome / Cromo.  
White porcelain diffuser / Difusor de porcelana blanca.  
GZ 10 230V 50W.



**8951.**

Matt nickel / Niquel mate.  
Black porcelain diffuser / Difusor de porcelana negra.  
GZ 10 230V 50W.



**8955.**

Chrome / Cromo.  
White porcelain diffuser / Difusor de porcelana blanca.  
E27 Par Halógena 230V 100W Max.



**8956.**

Matt nickel / Niquel mate.  
Black porcelain diffuser / Difusor de porcelana negra.  
E27 Par Halógena 230V 100W Max.



8950 / 8951.

12,5 x 12,5 cm

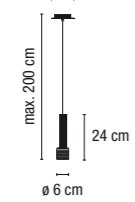

8955 / 8956.

12,5 x 12,5 cm

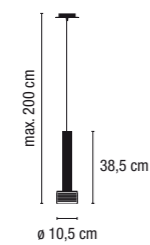

Ø 6 cm

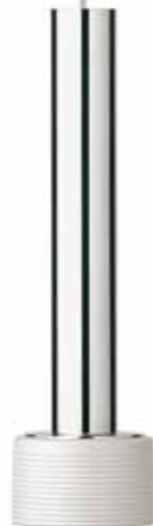

Ø 10,5 cm



Porcelain diffuser / Difusor de porcelana.

See the complete Sixties family in the spots section / Ver la familia Sixties en apartado spots.

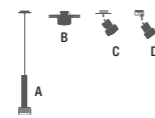

SIXTIES. Family / Familia  
Pages / Páginas: A-196. B-294. C-323/329. D-329.

HANGING LAMPS  
COLGANTES

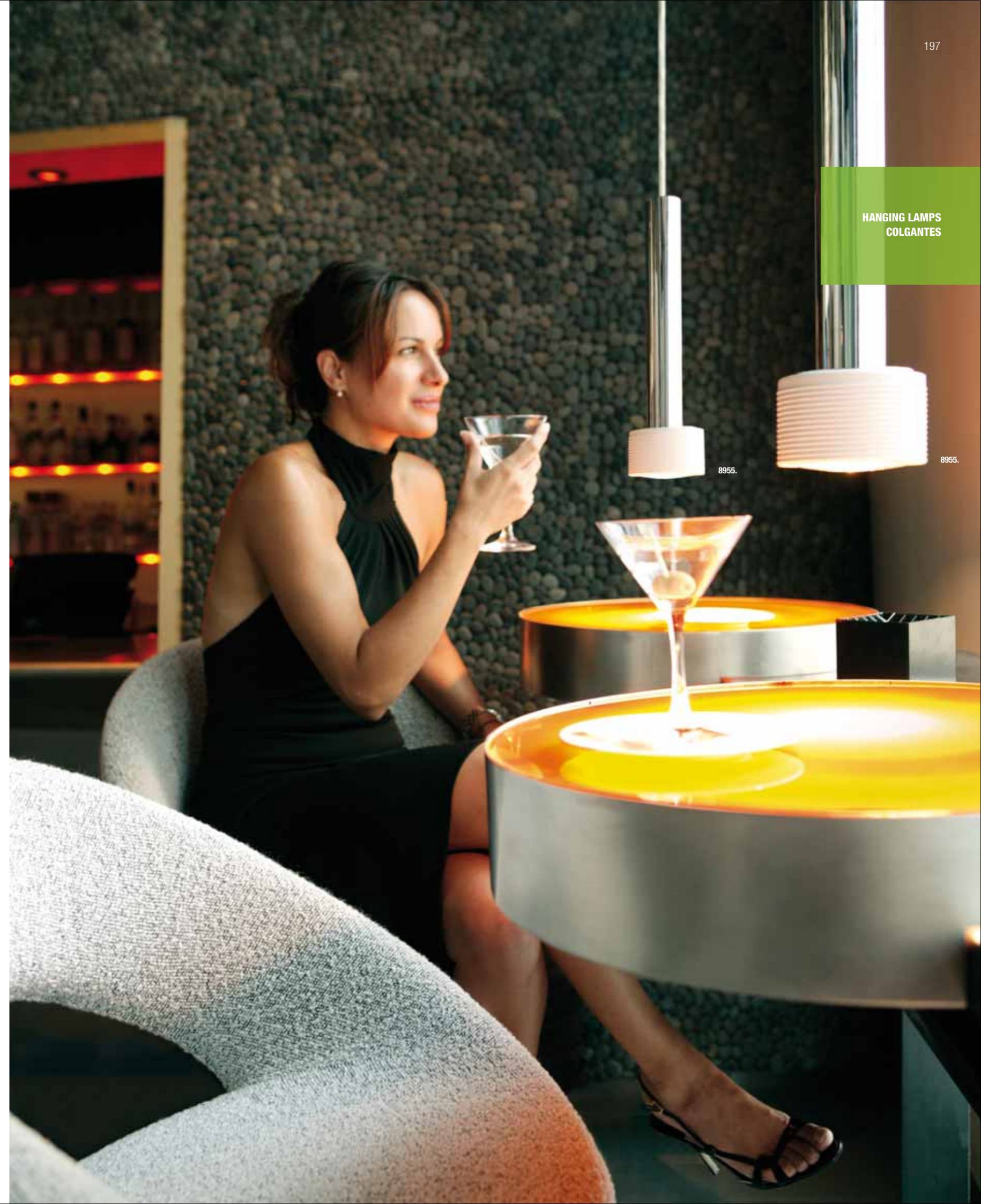

8955.

8955.



White lacquer / Lacado blanco.

Black lacquer / Lacado negro.

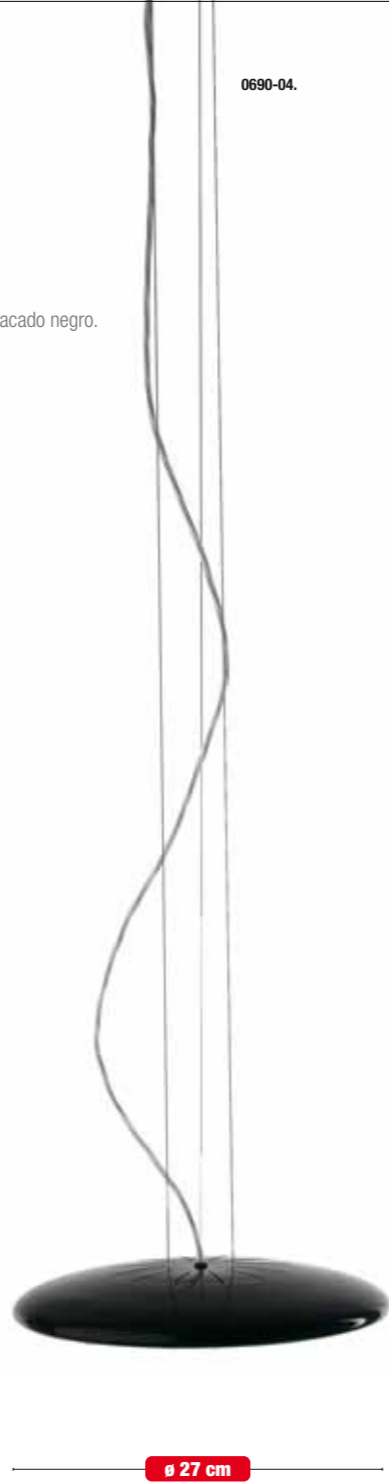
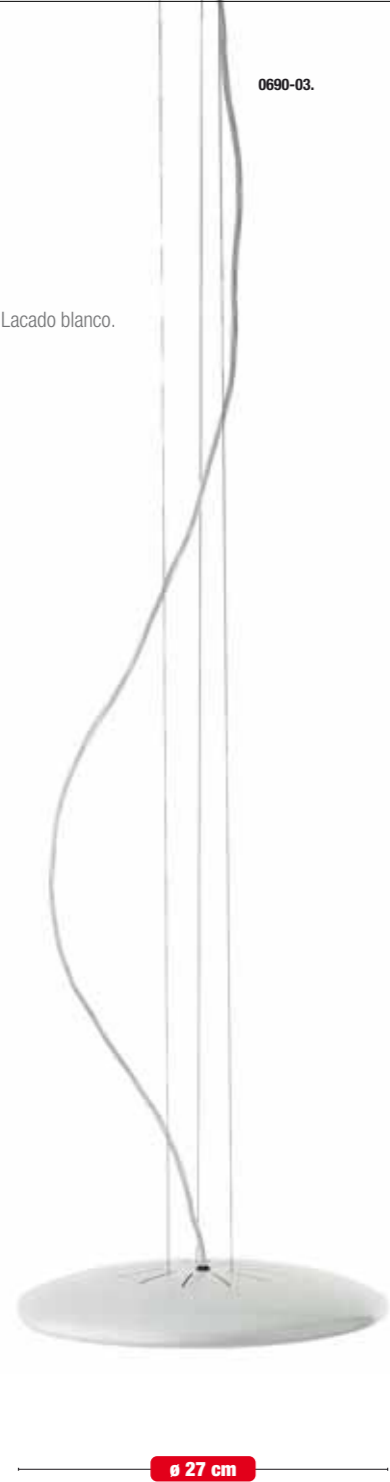

HANGING LAMPS  
COLGANTES



**Lollipop**

Design by Hopf & Wortman, büro für form.

**0690.**

White lacquer, black lacquer /  
Lacado blanco, lacado negro.  
Borosilicate glass diffuser /  
Difusor de vidrio de borosilicato.  
R7s 80mm. 230V 100W Max.

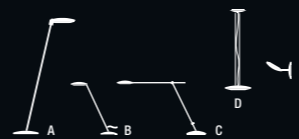

HANGING LAMPS  
COLGANTES

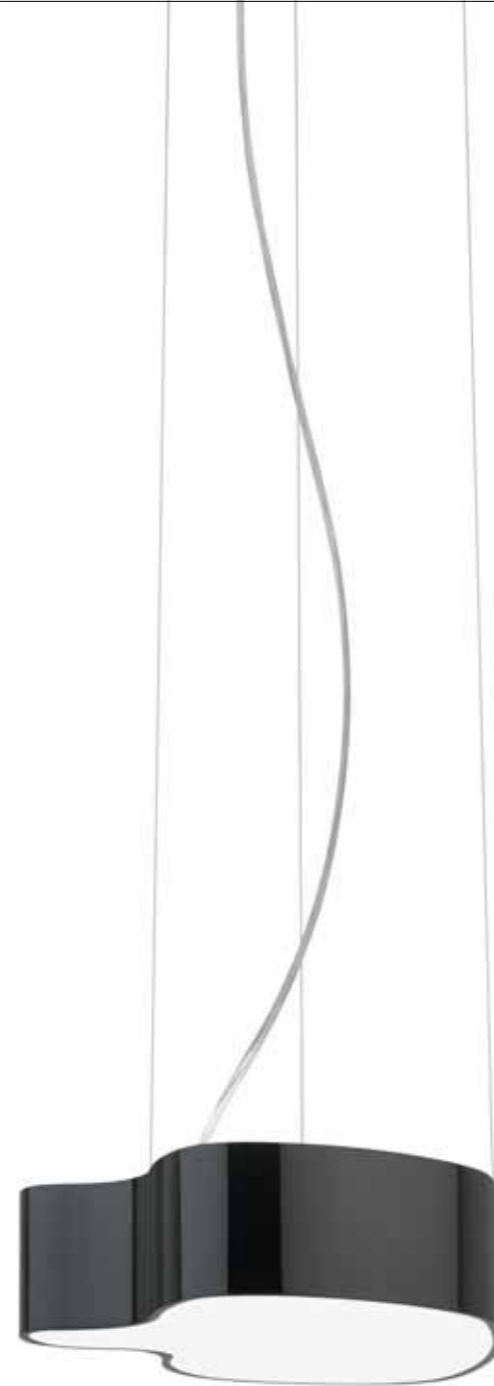
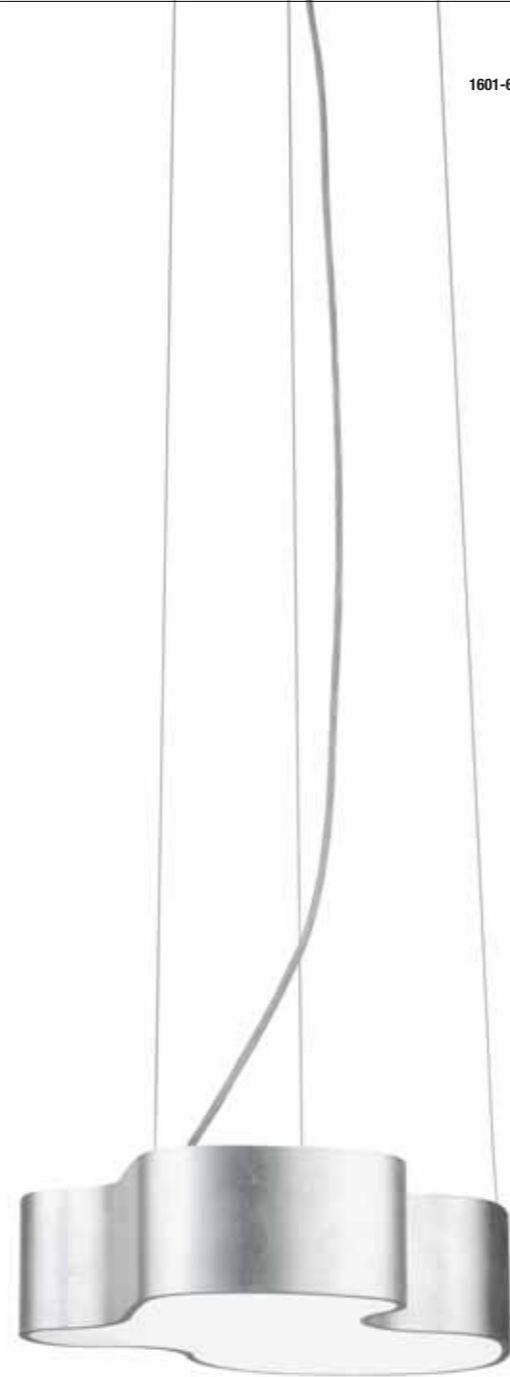

**Puzzle**

Design by Diego Fortunato.

**1600 / 1601 / 1602.**

White lacquer, Black lacquer and Silver lacquer /  
Lacado blanco, lacado negro y lacado plata.  
Optical glass diffuser / Difusor de vidrio óptico.  
3 x E14 Esférica Mate 40W Max.



1600.

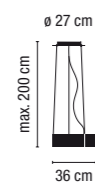

1601.

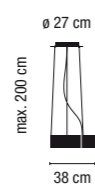

1602.

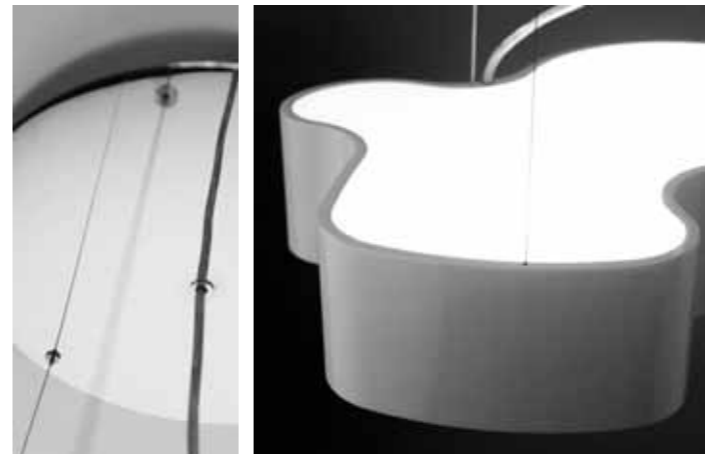
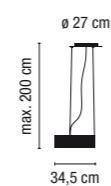

White lacquer / Lacado blanco. Silver lacquer / Lacado plata. Black lacquer / Lacado negro.

HANGING LAMPS  
COLGANTES

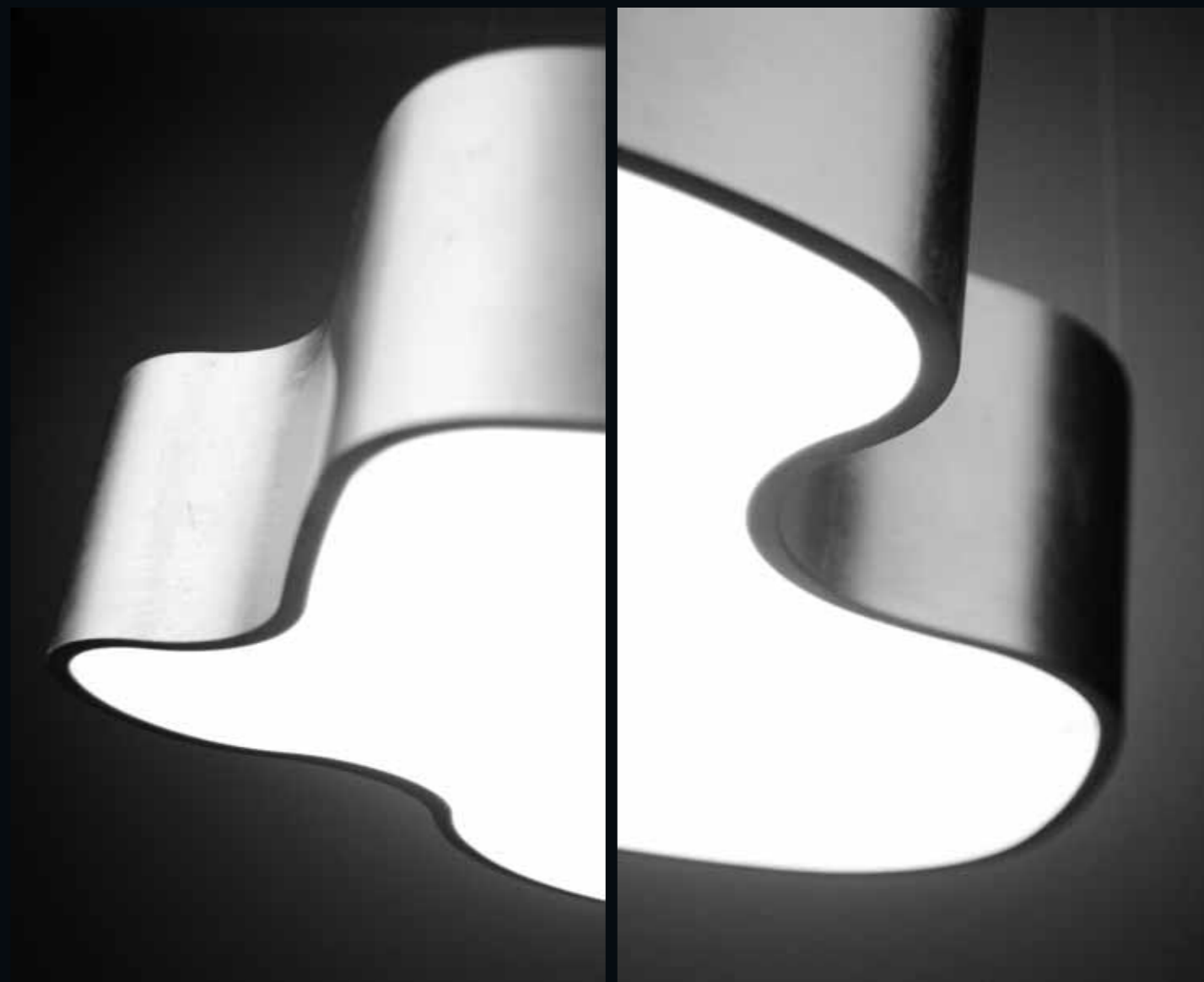
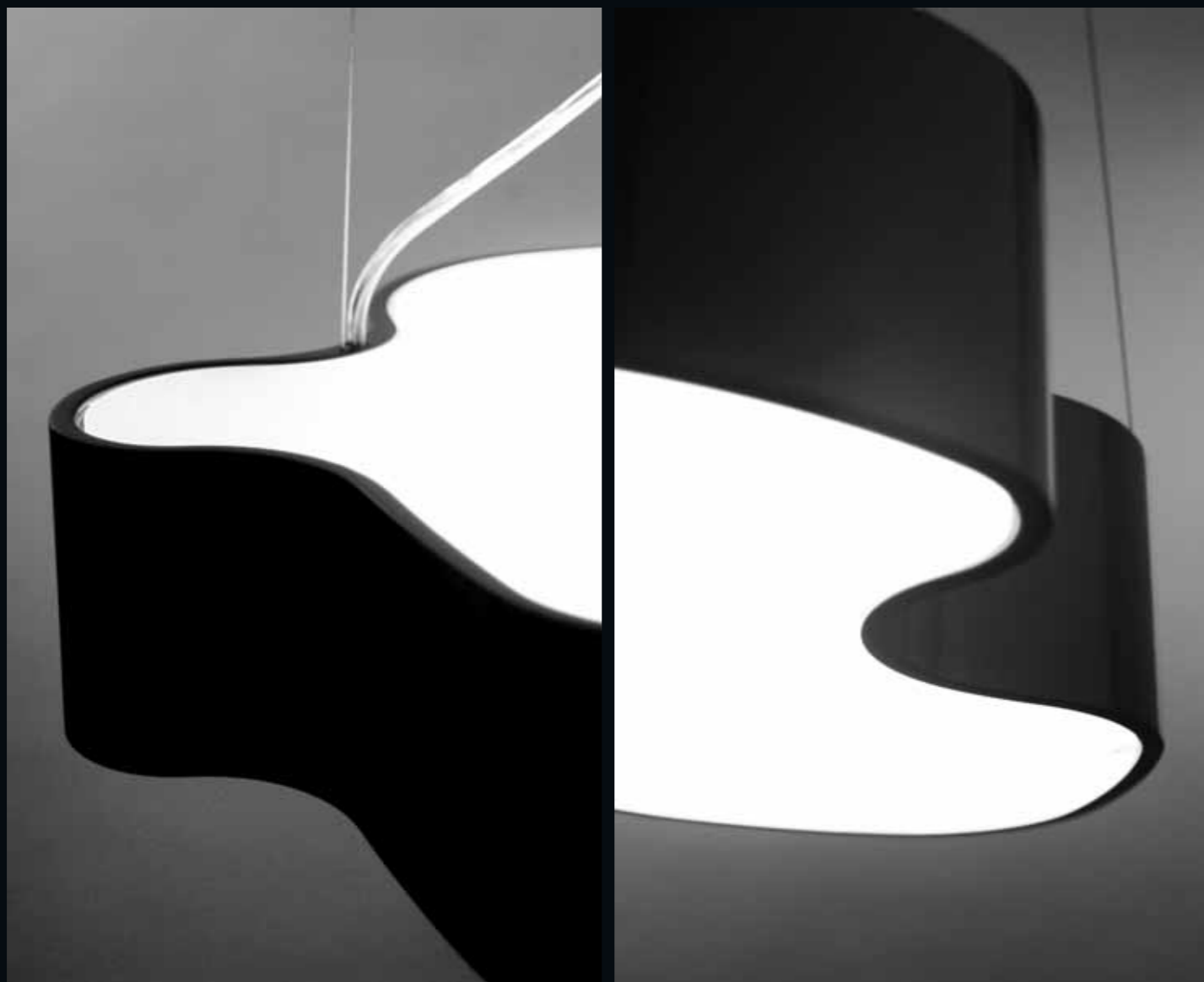

1600-04.

1601-04.

1602-04.

HANGING LAMPS  
COLGANTES



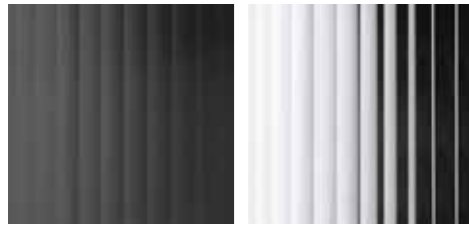

1150-04.  
Anodized black /  
Anodizado negro.

1150-01.  
Chrome / Cromado.

**Even**  
Design by Proli Diffusion Studio.

**1150.**  
Chrome or anodized black /  
Cromado y anodizado negro.  
Polyethylene diffuser /  
Difusor de polietileno.  
6 x E27 30W ( Osram Dulux EL)

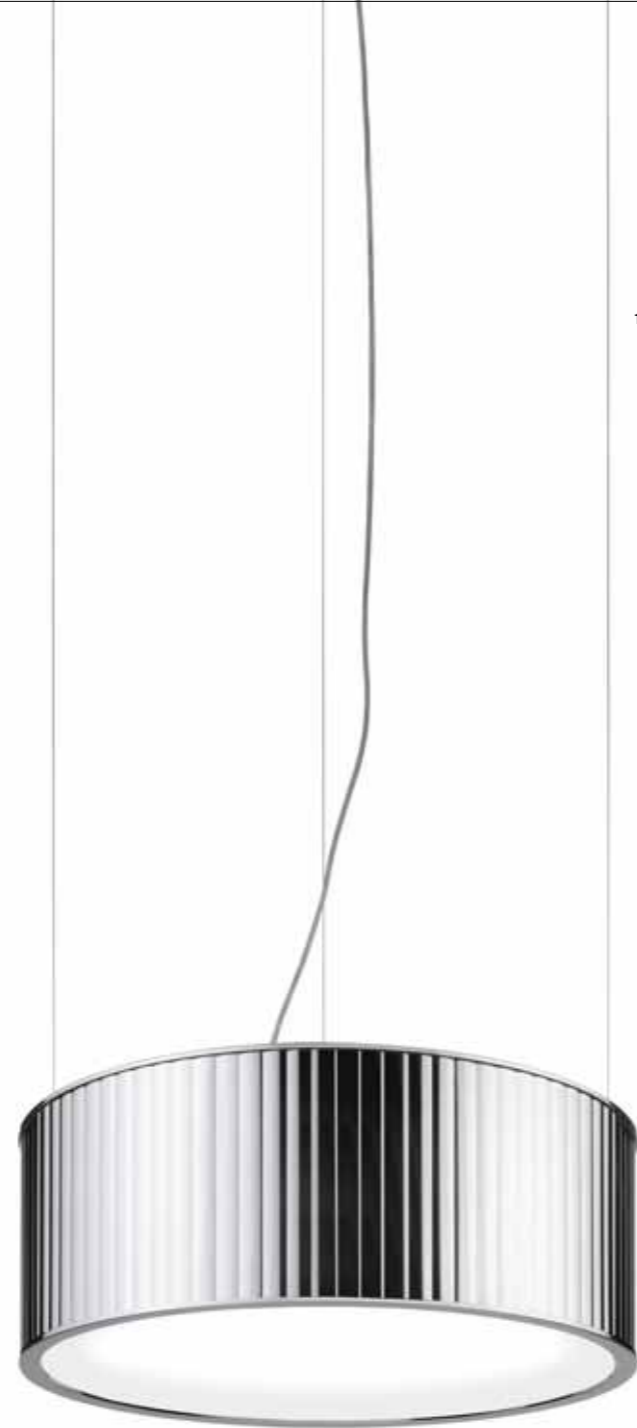
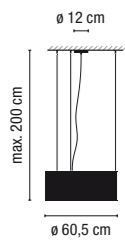

1150.

ø 60,5 cm

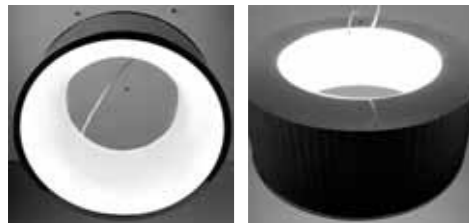

1150-04.

HANGING LAMPS  
COLGANTES



**Corner**

Design by Oscar & Sergi Devesa.

**8120 / 8121.**

Chrome / Cromo.

**8120:** 2 x GU 5,3 12V 50W.

**8121:** 4 x GU 5,3 12V 50W.



**8120.**



**8121.**

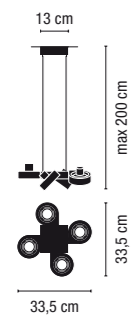

8120.

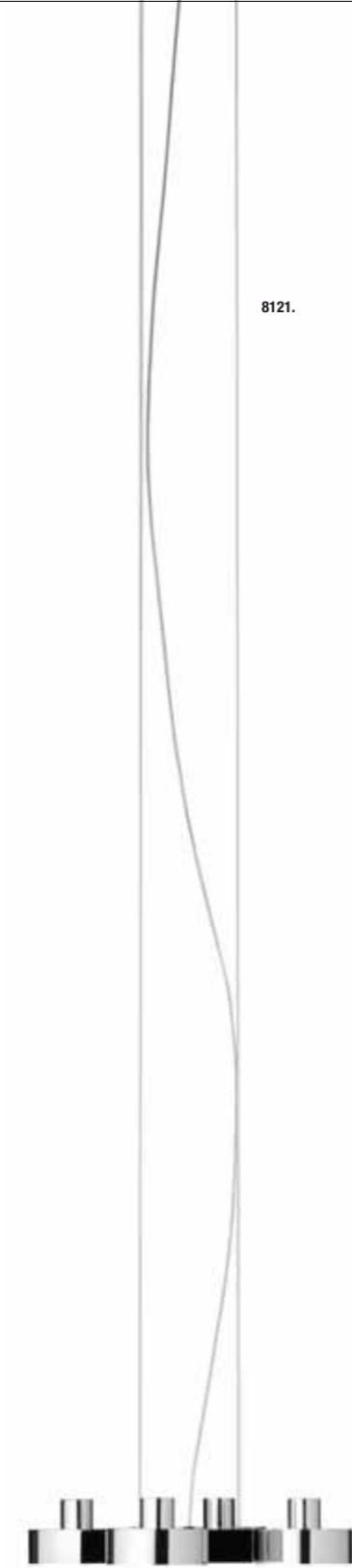

8121.

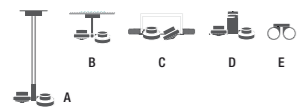



**Corner**  
Design by Oscar & Sergi Devesa.

**8125 / 8126.**  
Chrome / Cromo.  
**8125:** 2 x G53 12V 60W.  
**8126:** 4 x G53 12V 60W.

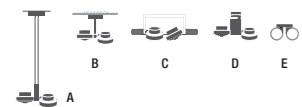
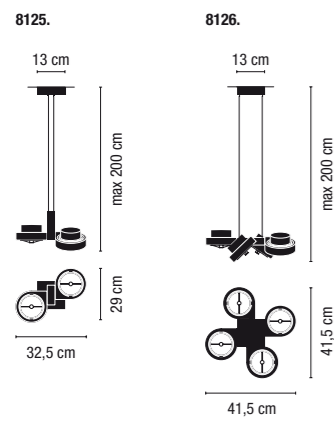

CORNER. Family / Familia  
Pages / Páginas: A-208/210. B-277/278. C-284/286/288.  
D-302/304. E-364/365.

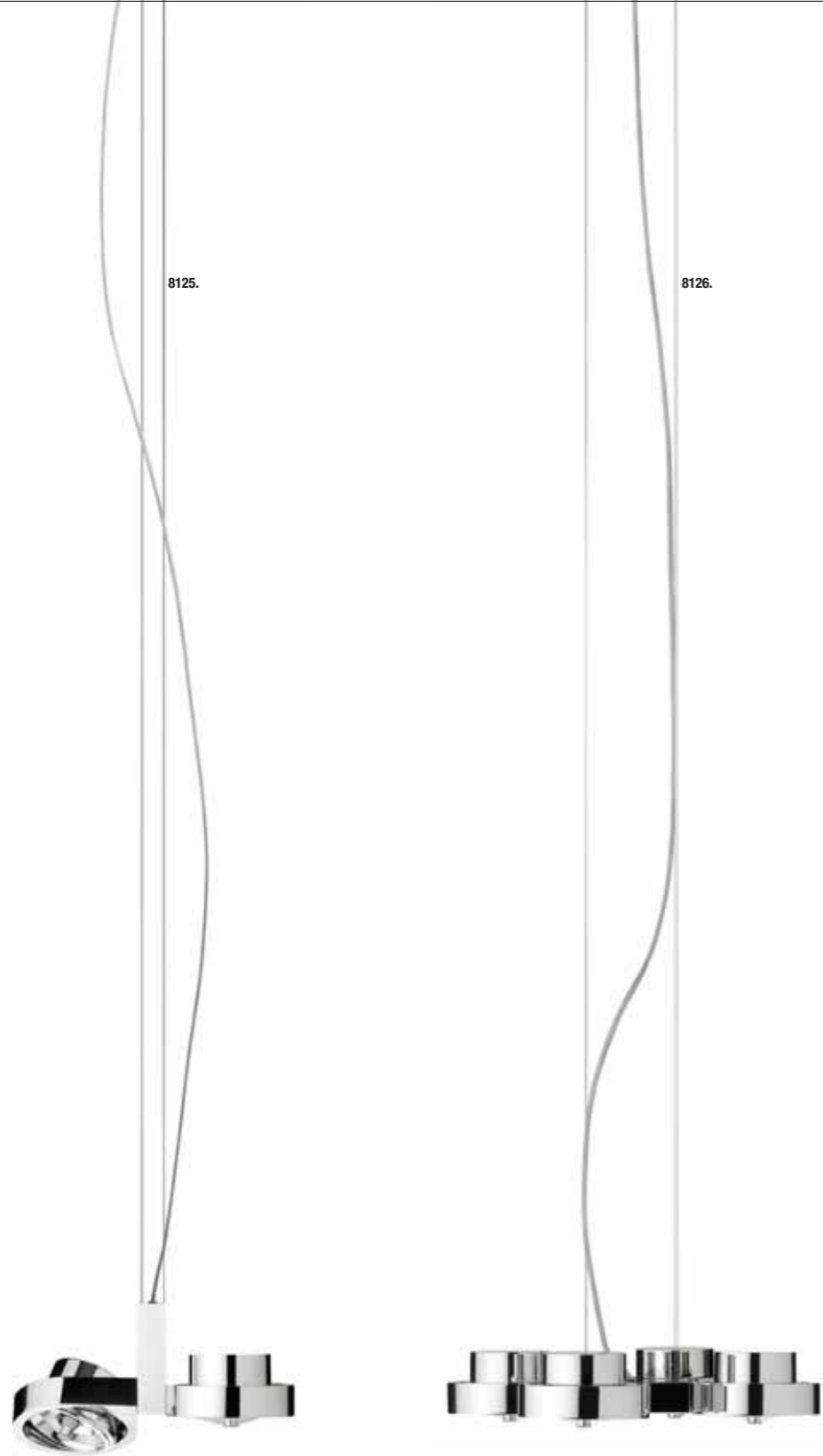

HANGING LAMPS  
COLGANTES



## Ceiling Lamps Plafones

Basik	273/275
Big	224
Chef	247
Corner	277/278
Funnel	218/222
Glamour	227
Lotto	269
Mini Quadra	256
Mini Top	265
Mini Top Glass	266
Quadra Ice	253
Quadra Ice Flat	259
Quadra Marc	260
Round Ice Flat	271
Sandwich	243/245
Tecto	231/235/237/239
Watch	249



2004.  
Lacado negro / black lacquer.



2004.  
Red lacquer / Lacado rojo.



2004.  
Gold finish / Acabado oro



CEILING LAMPS  
PLAFONES

2004.  
White lacquer / Lacado blanco.



2004.  
Chrome / Cromo.



® THE ORIGINAL



mini

Ø 22 cm



2004.

**Mini Funnel**

White lacquer, black lacquer,  
red lacquer, chrome or gold finis /  
Lacado blanco, lacado negro,  
lacado rojo, cromo y acabado oro.  
Aluminium diffuser / Difusor de aluminio.

**2004.**  
2 x G9 230V 75W Max.  
(OSRAM HALOPIN).



22 cm

10 cm

Ø 12 cm

**mini**

2004-03. White lacquer / Lacado blanco. 2004-04. Black lacquer / Lacado negro. 2004-06. Red lacquer / Lacado rojo.



2004-01. Chrome / Cromo. 2004-51. Gold finish / Acabado oro.

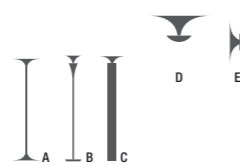

FUNNEL. Family / Familia  
Pages / Páginas: A-32. B-34. C-37. D-218/222. E-370/375.

2004-03.

CEILING LAMPS  
PLAFONES

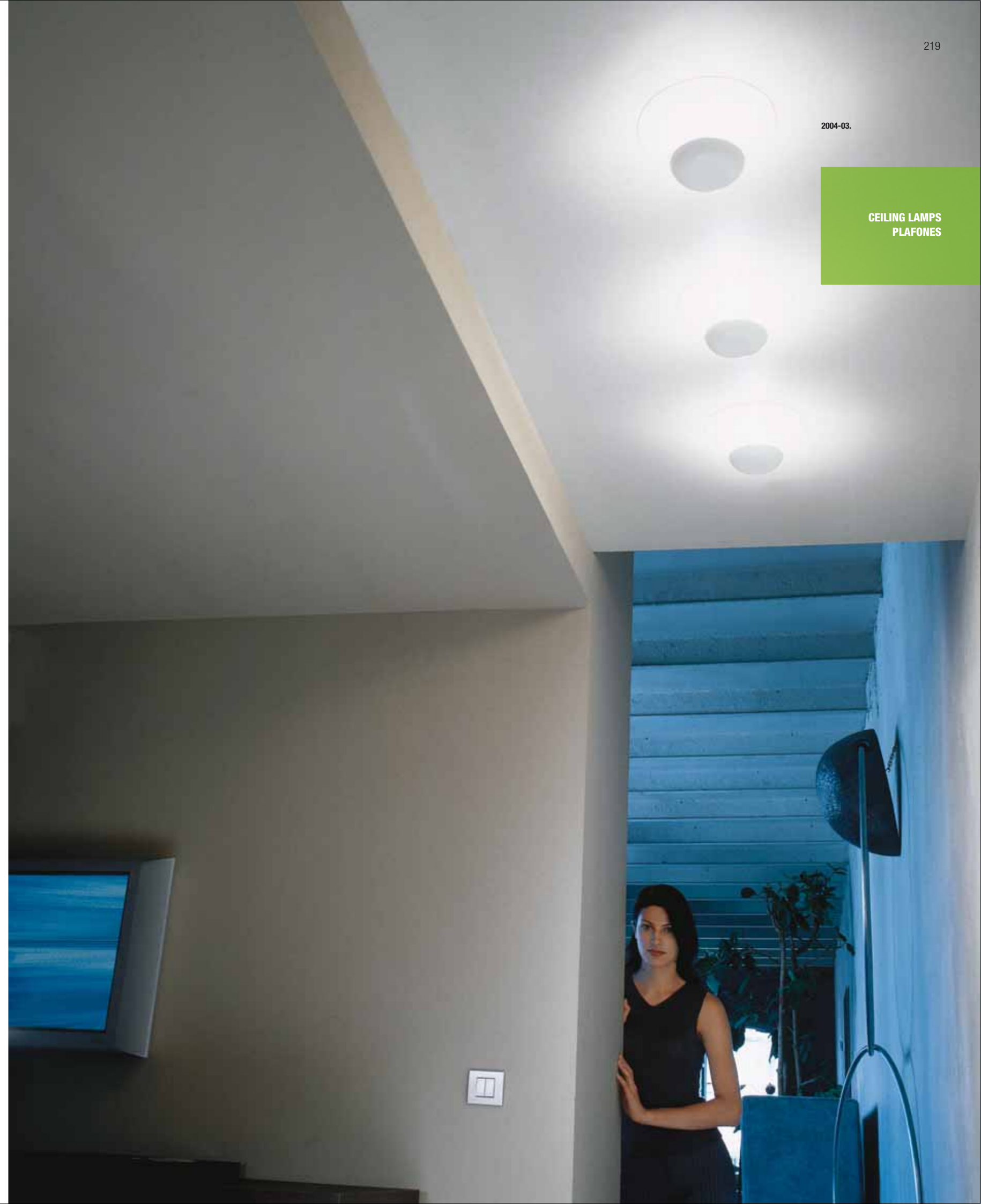

© THE ORIGINAL

mini

Ø 22 cm

2004-51.



104



CEILING LAMPS  
PLAFONES

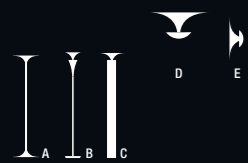

HALOGEN / HALÓGENO

**Funnel**

Design by Ramón Benedito.

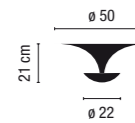
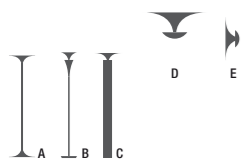
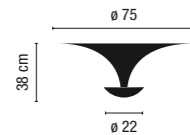
White lacquer / lacado blanco.  
Aluminium diffuser / Difusor de aluminio.**2005.**2 x R7s 80mm.  
230V 150W Max.**2007.**3 x R7s 80mm.  
230V 100W Max.**2006.**3 x R7s 80mm.  
230V 150W Max.FUNNEL. Family / Familia  
Pages / Páginas: A-32. B-34. C-37. D-218/222. E-370/375.**® THE ORIGINAL**

2007.

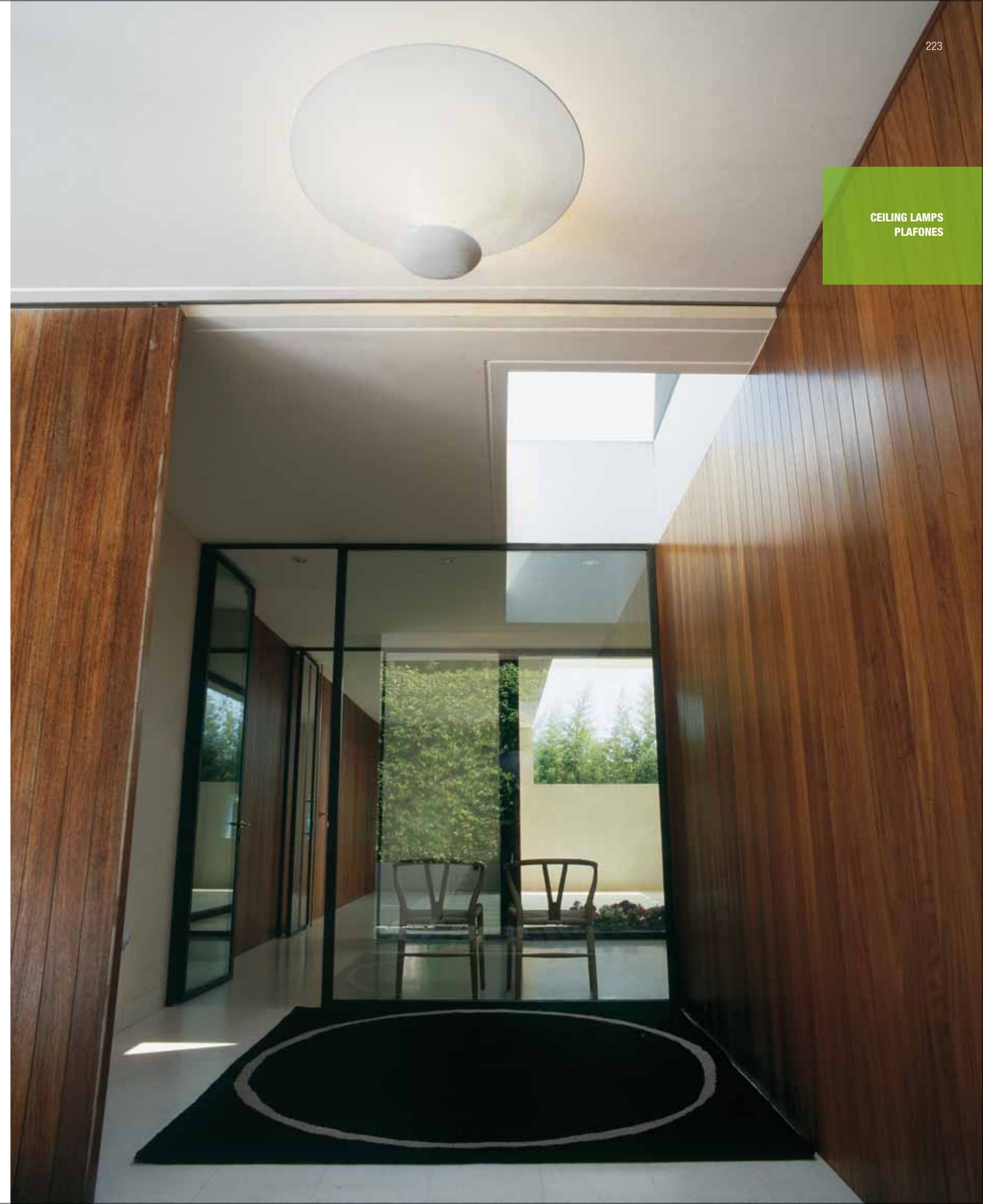

Ø 50 cm

CEILING LAMPS  
PLAFONES

**Big**

Design by Lievore, Altherr, Molina.

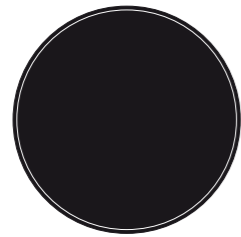
Chrome / Cromo.  
Methacrylate diffuser / Difusor de metacrilato.**0530.**5 x E27 220 / 240V 30W  
(Osram Dulux E).

ø120 cm

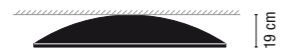
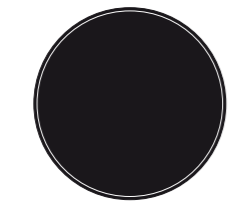
**0531.**5 x E27 220 / 240V 20W  
(Osram Dulux E).

ø100 cm



0530-01.

Ø 120 cm

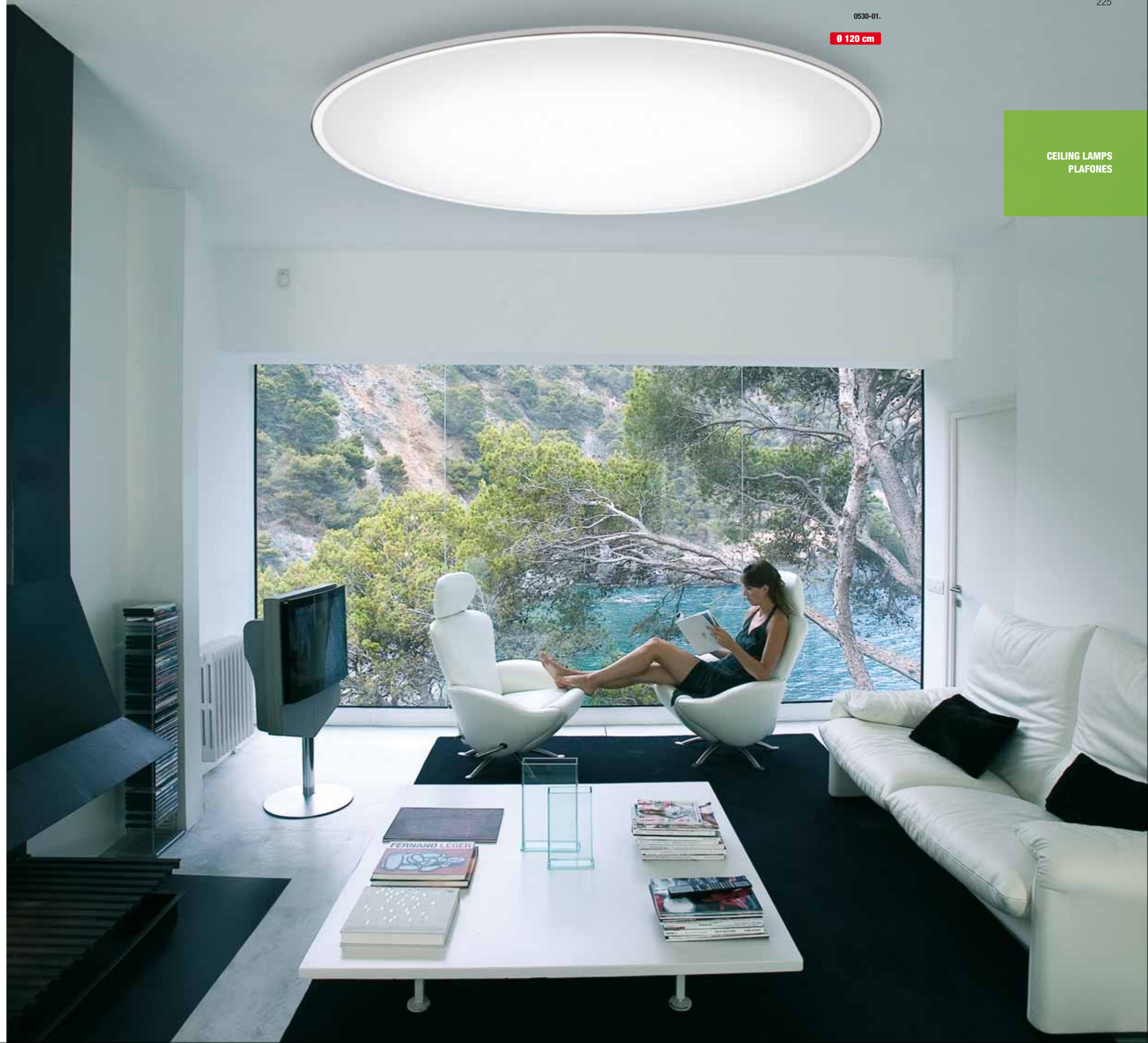
CEILING LAMPS  
PLAFONES



### Glamour

Design by Proli Diffusion Studio.

#### 5101.

3 x E27 Mate  
230V 100W Max.

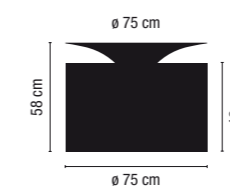

#### 5102.

3x E27 Mate  
230V 100W Max.

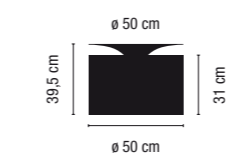

#### 5103.

4x E27 Mate  
230V 100W Max.

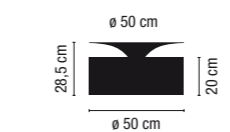

White lacquered / Lacado blanco.

**5101-03:** Cream cotton ribbon diffuser / Difusor de cinta de algodón color crudo.  
**5101-04:** Black cotton ribbon diffuser / Difusor de cinta de algodón color negro.  
**5101-47:** Black glamour textile diffuser / Difusor costura glamour negro.

White lacquered / Lacado blanco.

**5102-03:** Cream cotton ribbon diffuser / Difusor de cinta de algodón color crudo.  
**5102-04:** Black cotton ribbon diffuser / Difusor de cinta de algodón color negro.  
**5102-47:** Black glamour textile diffuser / Difusor costura glamour negro.

White lacquered / Lacado blanco.

**5103-03:** Cream cotton ribbon diffuser / Difusor de cinta de algodón color crudo.  
**5103-04:** Black cotton ribbon diffuser / Difusor de cinta de algodón color negro.

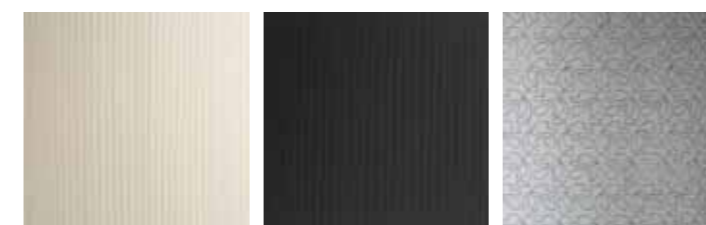

**5101-03 / 5102-03 / 5103-03.**

Cream cotton ribbon diffuser /  
Difusor de cinta de algodón  
color crudo.

**5101-04 / 5102-04 / 5103-04.**

Black cotton ribbon diffuser /  
Difusor de cinta de algodón  
color negro.

**5101-47 / 5102-47.**

Black glamour textile diffuser /  
Difusor costura glamour negro.



Methacrylate disc on the bottom of the shade /  
Disco de metacrilato en la parte inferior de la pantalla.

CEILING LAMPS  
PLAFONES

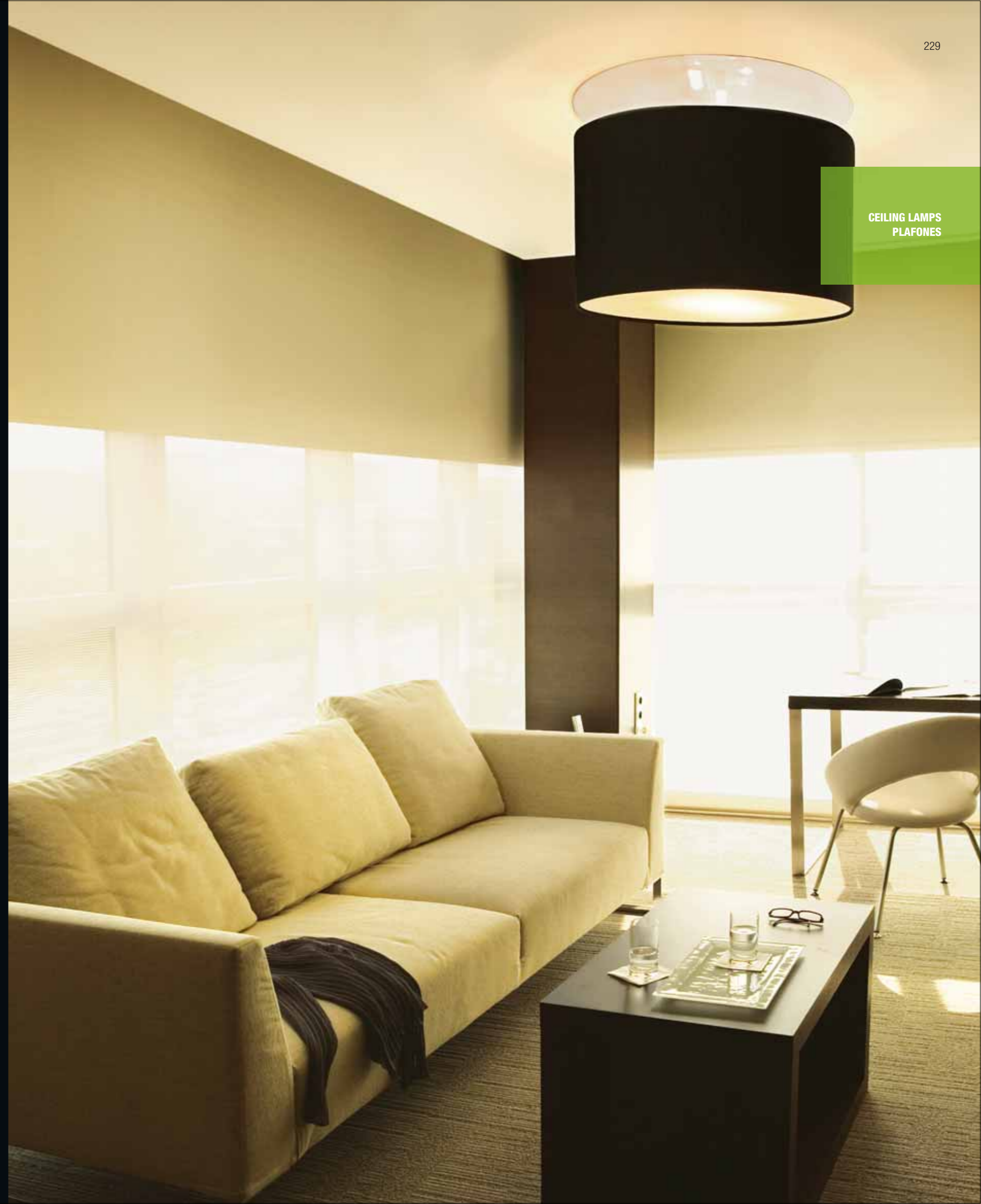

4353. ® THE ORIGINAL



60 x 60 cm

MAXI

mini

16 x 16 cm



4350.

**Tecto**

Design by Prolif Diffusion Studio.

Matt stainless steel, shiny stainless steel /  
Acero inoxidable mate, acero inoxidable brillo.  
Optical glass diffuser / Difusor de vidrio óptico.

**4353.**

R7s 117 mm.  
230V 300W Max.

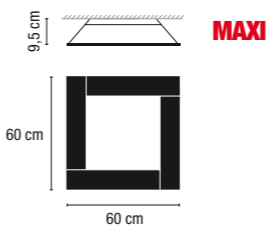

**4354.**

4 x 2G11 24W Max.

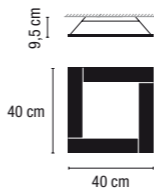

**4352.**

R7s 117 mm.  
230V 300W Max.

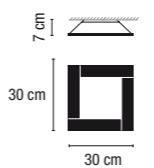

**4351.**

R7s 80mm.  
230V 150W Max.

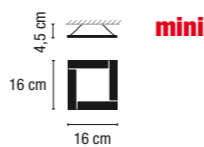

**4350.**

G9 230V 60W Max.  
(OSRAM HALOPIN).

**Surface / Superficie**



**STAINLESS  
STEEL /  
ACERO  
INOXIDABLE**

Possible to combine matt nickel and chrome /  
Posibilidad de combinar níquel mate y cromo



Shiny stainless steel /  
Acero inoxidable brillante.

Matt stainless steel /  
Acero inoxidable mate.

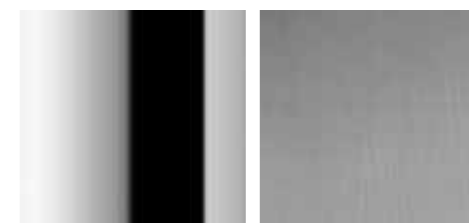

TECTO. Family / Familia  
Pages / Páginas: A-231. B-235. C-237. D-239. E-383. F-384. G-386. H-388.





4352.

4353.



CEILING LAMPS  
PLAFONES



**Tecto**  
Design by Proli Diffusion Studio.

Shiny stainless steel or matt stainless steel /  
Acero inoxidable brillo o acero inoxidable mate.  
Optical glass diffuser / Difusor de vidrio óptico.

<p><b>4370.</b> R7s 117mm. 230V 300W Max.</p>	
<p><b>4375.</b> G9 230V 60 W Max.</p>	

**Surface / Superficie**

STAINLESS  
STEEL /  
ACERO  
INOXIDABLE

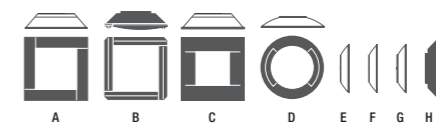

4357.

® THE ORIGINAL



40 x 40 cm

mini

16 x 16 cm

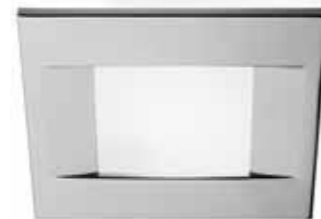

4355.

**Tecto**

Design by Prolif Diffusion Studio.

Matt stainless steel, shiny stainless steel /  
Acero inoxidable mate, acero inoxidable brillo.  
Optical glass diffuser / Difusor de vidrio óptico.

**4357.**

R7s 117 mm.  
230V 300W Max.

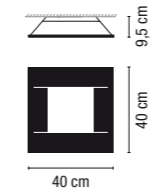

**4356.**

R7s 80mm.  
230V 150W Max.

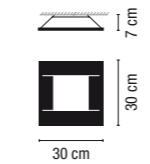

**4355.**

G9 230V 60W Max.  
(OSRAM HALOPIN).  
Opal glass diffuser /  
Difusor de vidrio opal.

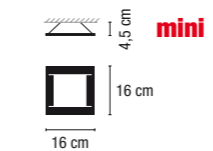

**Surface / Superficie**

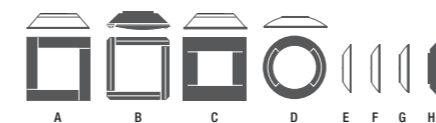
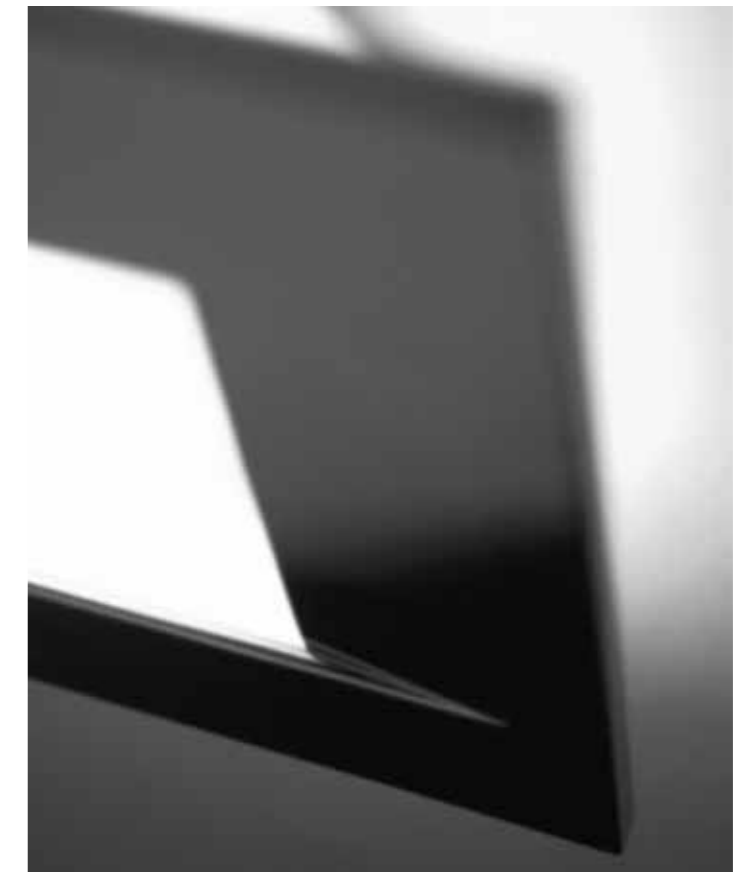

TECTO. Family / Familia  
Pages / Páginas: A-231. B-235. C-237. D-239. E-383. F-384. G-386. H-388.

STAINLESS  
STEEL /  
ACERO  
INOXIDABLE



**Tecto**  
Design by Proli Diffusion Studio.

Matt stainless steel, shiny stainless steel /  
Acero inoxidable mate, acero inoxidable brillo.  
Optical glass diffuser / Difusor de vidrio óptico.

<p><b>4367.</b> R7s 117 mm. 230V 300W Max.</p>	
<p><b>4366.</b> R7s 80mm. 230V 150W Max.</p>	
<p><b>4365.</b> G9 230V 60W Max. (OSRAM HALOPIN). Opal glass diffuser / Difusor de vidrio opal.</p>	

**Surface / Superficie**

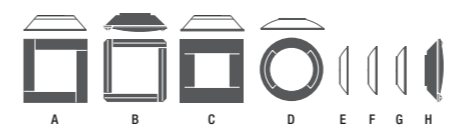

TECTO. Family / Familia  
Pages / Páginas: A-231. B-235. C-237. D-239. E-383. F-384. G-386. H-388.

STAINLESS  
STEEL /  
ACERO  
INOXIDABLE



CEILING LAMPS  
PLAFONES

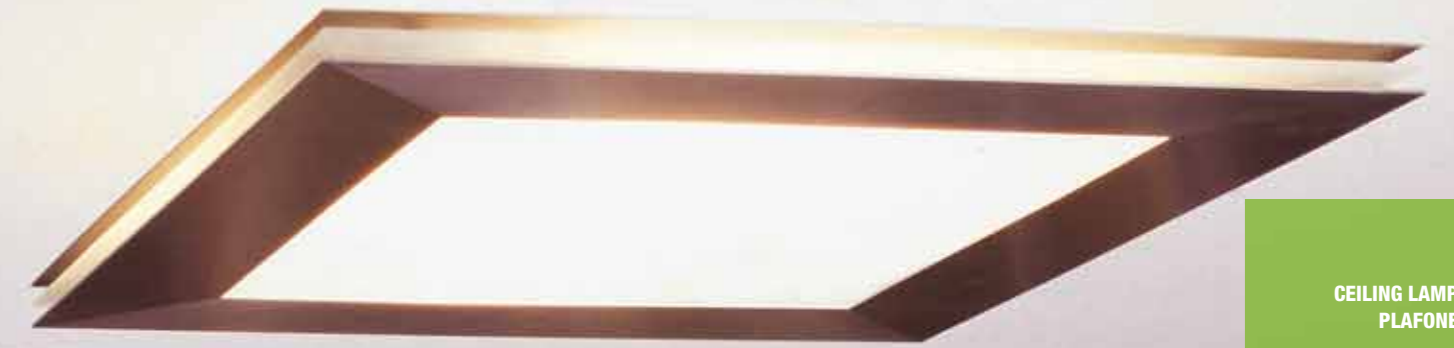



**Sandwich**  
Design by Prolif Diffusion Studio.

Matt nickel / Níquel mate.  
Optical glass diffuser / Difusor de vidrio óptico.

<p><b>4411.</b></p> <p>R7s 117 mm. 230V 300W Max.</p>	
<p><b>4410.</b></p> <p>R7s 117 mm. 230V 300W Max.</p>	
<p><b>4415.</b></p> <p>R7s 117 mm. 230V 300W Max.</p>	
<p><b>4414.</b></p> <p>R7s 117 mm. 230V 300W Max.</p>	

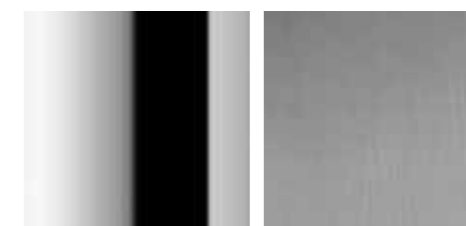

Chrome / Cromo.      Matt nickel / Níquel mate.

Chrome, matt nickel / Cromo, Níquel mate.  
Opal glass diffuser / Difusor de vidrio opal.

**8604.**

G9 230V 60W Max.  
(OSRAM HALOPIN).

mini

16 cm      5.5 cm

**Surface / Superficie**

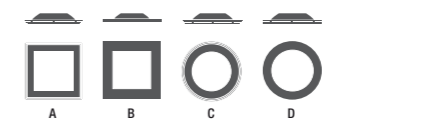

® THE ORIGINAL  
4400.



8606. ® THE ORIGINAL

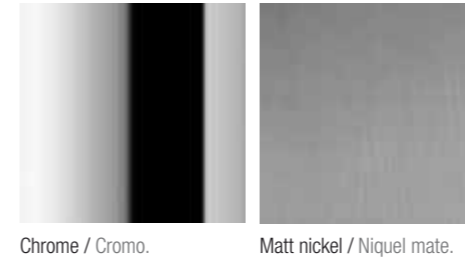

Chrome / Cromo. Matt nickel / Niquel mate.

**Sandwich**  
Design by Proli Diffusion Studio.

Matt nickel / Niquel mate.  
Optical glass diffuser / Difusor de vidrio óptico.

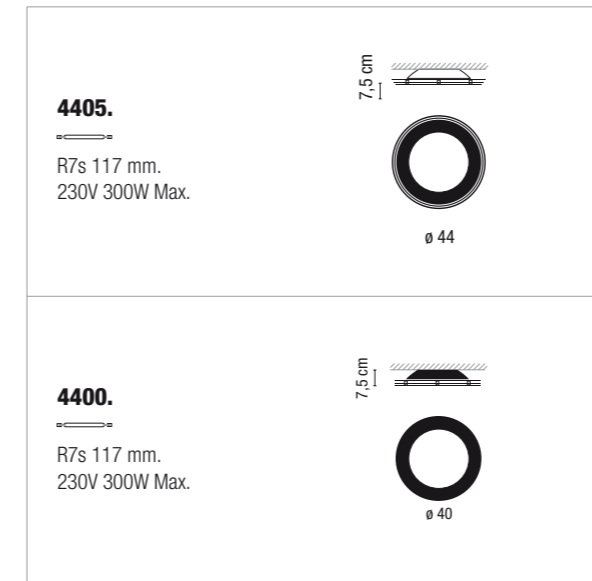

Chrome, matt nickel / Cromo, Niquel mate.  
Opal glass diffuser / Difusor de vidrio opal.

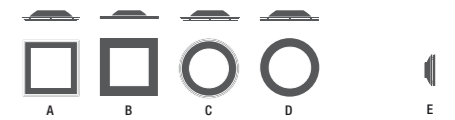



T-5 FLUORESCENT / T-5 FLUORESCENTE

© THE ORIGINAL

4425



CEILING LAMPS  
PLAFONES

**Chef**  
Design by Proli Diffusion Studio.

Stainless steel / Acero inoxidable.  
Optical glass diffuser / Difusor de vidrio óptico.

**4425.**

2 x G5 39W (T5).  
Electronic ballast /  
Reactancia electrónica.

**Weight / Peso 18 kg**

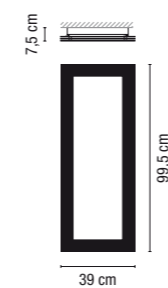

**4426.**

2 x G5 24W (T5).  
Electronic ballast /  
Reactancia electrónica.

**Weight / Peso 11 kg**

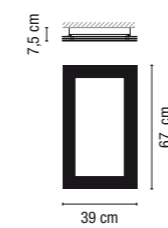

**4427.**

4 x G5 24W (T5).  
Electronic ballast /  
Reactancia electrónica.

**Weight / Peso 18 kg**

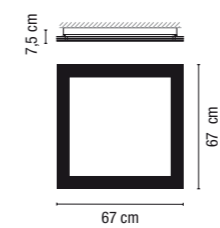





**Watch**  
Design by Proli Diffusion Studio.

Chrome / Cromo.  
Opal triplex blown-glass diffuser / Difusor de vidrio soplado opal triplex.

<p><b>4255.</b> R7s 117 mm. 230V 200W Max.</p>	
<p><b>4250.</b> G9 230V 60W Max. (OSRAM HALOPIN).</p>	<p><b>mini</b></p>
<p><b>4251.</b> GX53 9W.</p>	<p><b>mini</b></p>



CEILING LAMPS  
PLAFONES





**Quadra Ice**  
Design by Proli Diffusion Studio.

Optical glass diffuser / Difusor de vidrio óptico.

**1133.**  
R7s 117 mm.  
230V 300W Max.

**1132.**  
1 x GX13 40W Max (T5).  
1 x GX13 22W Max (T5).

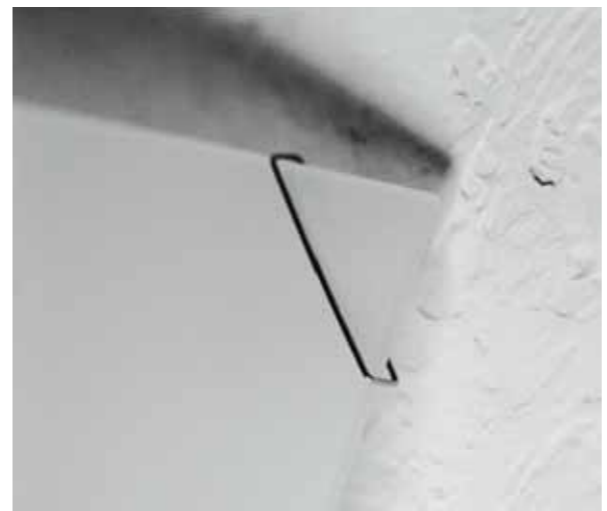

Optical glass diffuser / Difusor de vidrio óptico.

**1134.**  
R7s 117 mm.  
230V 300W Max.

**1129.**  
R7s 117 mm.  
230V 300W Max.

**1128.**  
R7s 80mm.  
230V 150W Max.

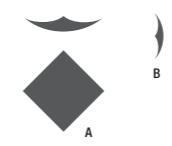

QUADRA ICE. Family / Familia  
Pages / Páginas : A-253. B-390.



1134.

1133.



CEILING LAMPS  
PLAFONES



® THE ORIGINAL

16,8 x 16,8 cm

mini

**Mini Quadra**  
Design by Proli Diffusion Studio.

Optical glass diffuser / Difusor de vidrio óptico.

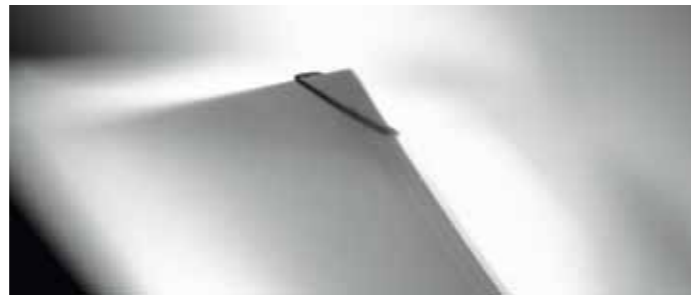

Top glass / Vidrio superior.

**8400.**  
 G9 230V 60W Max.  
 (OSRAM HALOPIN).

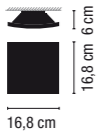

**mini**

**Surface / Superficie**

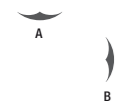
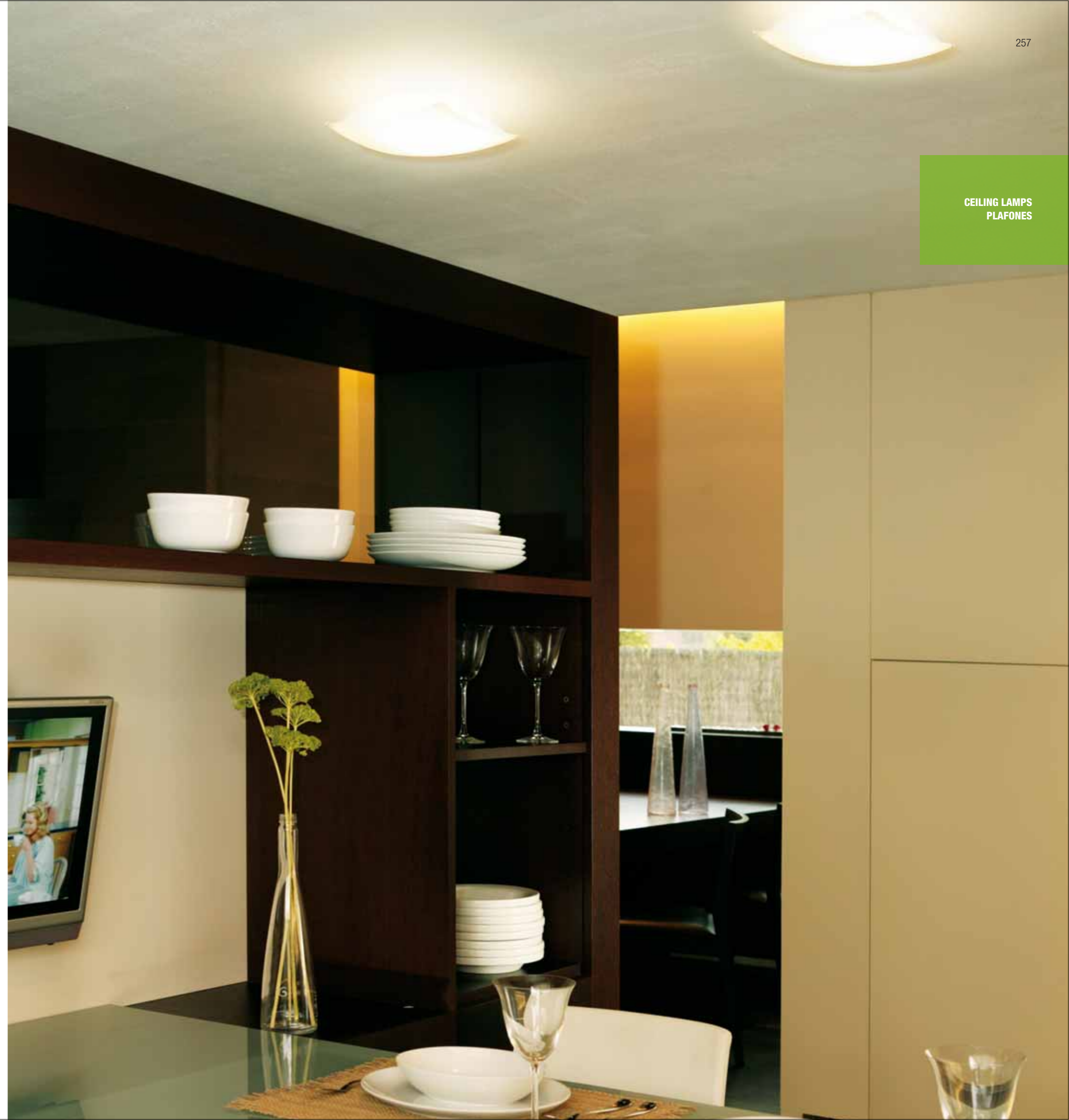



® THE ORIGINAL

1120.



® THE ORIGINAL

1125.

**Quadra Ice Flat**  
Design by Proli Diffusion Studio.

Optical glass diffuser / Difusor de vidrio óptico.

**1120.**

R7s 117mm.  
230V 300W Max.

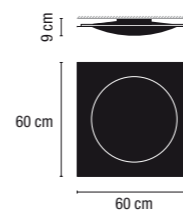

**1121.**

1 x GX13 40W Max (T5).  
1 x GX13 22W Max (T5).

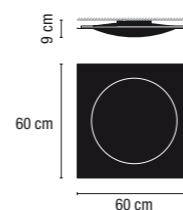

**1125.**

G9 230V 60W Max  
(OSRAM HALOPIN).

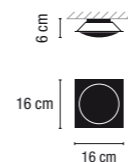

**Quadra Marc**

Design by Proli Diffusion Studio.

Chrome, matt nickel / Cromo, níquel mate.  
Optical glass diffuser / Difusor de vidrio óptico.

**4311.**  
R7s 117 mm.  
230V 300W Max.

**4312.**  
1 x GX13 40W Max (T5).  
1 x GX13 22W Max (T5).

Chrome, satin gold, matt nickel / Cromo, baño oro brósse, níquel mate.  
Optical glass diffuser / Difusor de vidrio óptico.

**4310.**  
R7s 117 mm.  
230V 300W Max.

**4309.**  
R7s 117 mm.  
230V 300W Max.

**4308.**  
R7s 80mm.  
230V 150W Max.

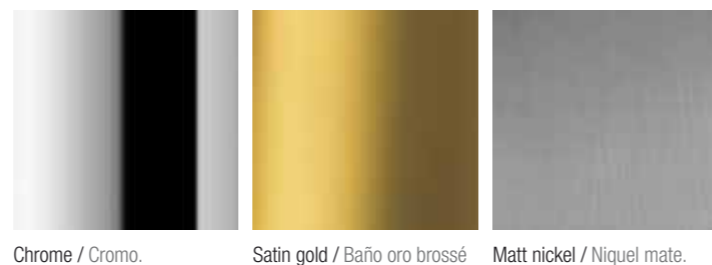

CEILING LAMPS  
PLAFONES

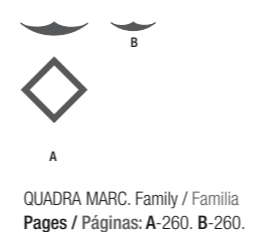



CEILING LAMPS  
PLAFONES

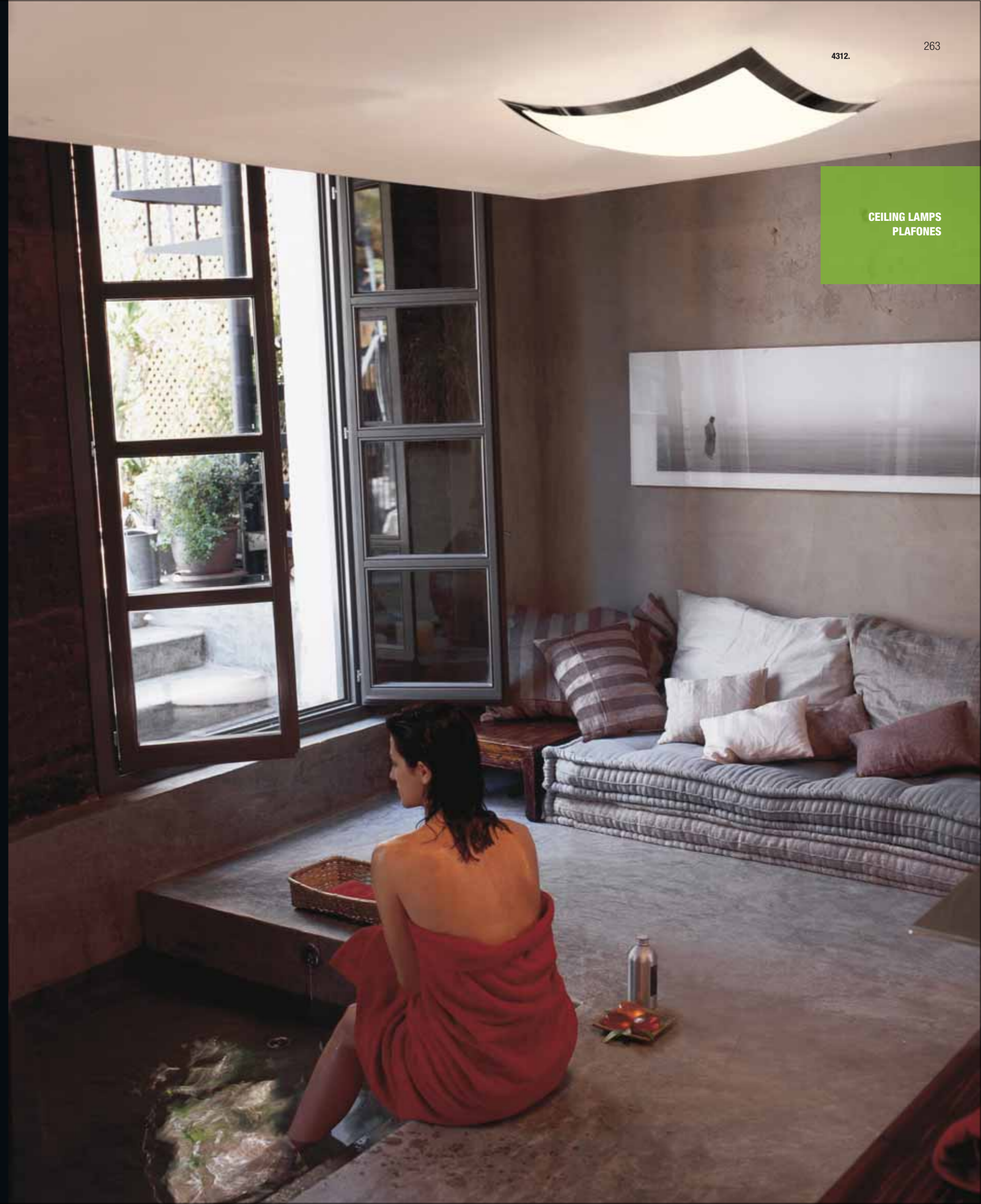





8500.

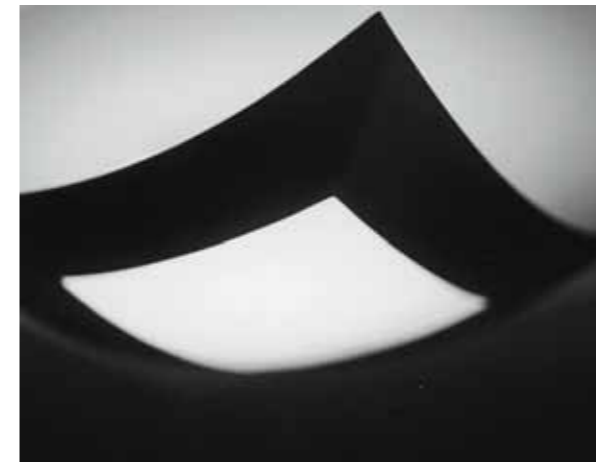

**Mini Top**  
Design by Proli Diffusion Studio.

Matt nickel / Níquel mate.  
Optical glass diffuser / Difusor de vidrio óptico.

**8500.**

G9 230V 60W Max.  
(OSRAM HALOPIN).

5 cm

15,5 cm  
15,5 cm

**Surface / Superficie**

**8502.**

G9 230V 60W Max.  
(OSRAM HALOPIN).

5 cm

15,5 cm  
15,5 cm

**Surface / Superficie**

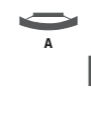

MINI TOP. Family / Familia  
Pages / Páginas: A-265/266. B-403.

mini

15,5 x 15,5 cm



8502.

® THE ORIGINAL

mini

15,5 x 15,5 cm



8500.

® THE ORIGINAL

® THE ORIGINAL

8492.



**Mini Top Glass**

Design by Prolí Diffusion Studio.

Matt nickel / Níquel mate .  
Optical glass diffuser / Difusor de vidrio óptico.

**8490.**

G9 230V 60W Max.  
(OSRAM HALOPIN).

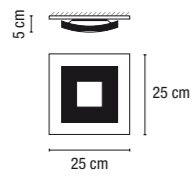

**8491.**

2 x G9 230V 60W Max.  
(OSRAM HALOPIN).

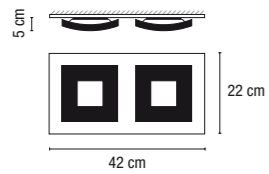

**8492.**

3 x G9 230V 60W Max.  
(OSRAM HALOPIN).

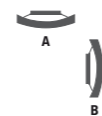
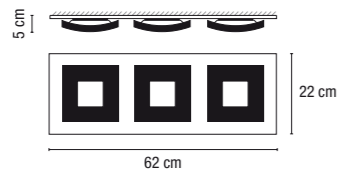

MINI TOP. Family / Familia  
Pages / Páginas: A-265/266. B-403.



8492.

CEILING LAMPS  
PLAFONES





**Lotto**  
Design by Proli Diffusion Studio.

Matt nickel / Níquel mate.  
Optical glass diffuser / Difusor de vidrio óptico.

<p><b>1192.</b> Halógena Tubular E27 230V 250W Max.</p>	<p>19 cm 45 cm x 45 cm</p>
<p><b>1196.</b> Halógena Tubular E27 230V 250W Max.</p>	<p>19 cm 55 cm</p>
<p><b>1186.</b> G9 230V 40W Max. (OSRAM HALOPIN).</p>	<p>8 cm Ø 9 cm Ø 20 cm</p> <p><b>mini</b></p>
<p><b>1187.</b> G9 230V 40W Max. (OSRAM HALOPIN).</p>	<p>8 cm Ø 9 cm 17 cm</p> <p><b>mini</b></p>

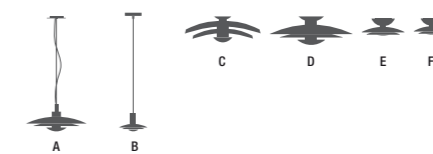



### Round Ice Flat

Design by Prolif Diffusion Studio.

Chrome / Cromo.  
Optical Glass diffuser / Difusor de vidrio óptico.

#### 1114.

1 x GX13 40W Max (T5).  
1 x GX13 22W Max (T5).

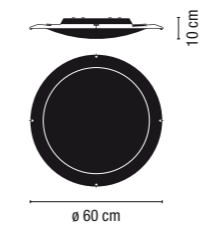

#### 1115.

R7s 117mm.  
230V 300W Max.

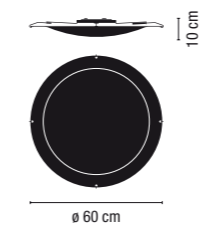

**Surface / Superficie**



Ø 14 cm

8633.



Ø 10 cm

8631.



**Basik**

Design by Proli Diffusion Studio.

Chrome / Cromo.  
Borosilicate diffuser / Difusor de borosilicato.

**8631.**

G9 230V 40W Max.  
(OSRAM HALOPIN).

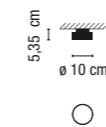

**Surface / Superficie**

**8633.**

G9 230V 40W Max.  
(OSRAM HALOPIN).

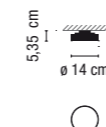

**Surface / Superficie**



CEILING LAMPS  
PLAFONES



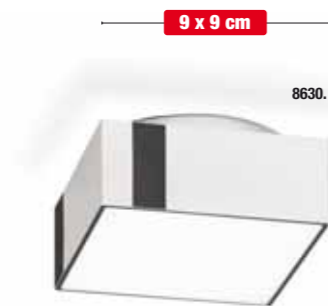

**Basik**  
Design by Proli Diffusion Studio.

Chrome / Cromo.  
Borosilicate diffuser / Difusor de borosilicato.

<p><b>8630.</b> G9 230V 40W Max. (OSRAM HALOPIN).</p>	
<p><b>Surface / Superficie</b></p>	
<p><b>8632.</b> G9 230V 40W Max. (OSRAM HALOPIN).</p>	
<p><b>Surface / Superficie</b></p>	





8111.

**Corner**  
Design by Oscar & Sergi Devesa.

Chrome / Cromo.

**8110.**  
▲  
GU 5,3 12V 50W

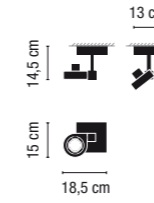

**8111.**  
▲  
2 x GU 5,3 12V 50W

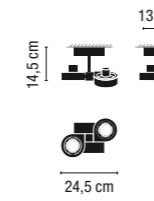

**8112.**  
▲  
4 x GU 5,3 12V 50W

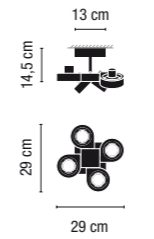

8110.



8111.



8112.

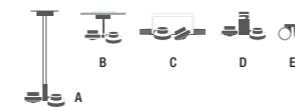





CORNER. Family / Familia  
Pages / Páginas: A-208/210. B-277/278. C-284/286/288.  
D-302/304. E-364/365.

**Corner**

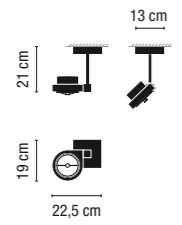
Design by Oscar & Sergi Devesa.

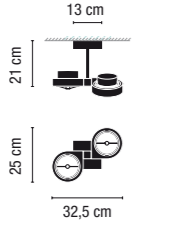
Chrome / Cromo.

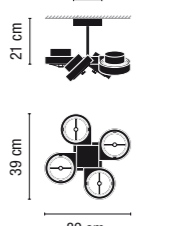
<p><b>8115.</b>                    G53 12V 60W</p>	
<p><b>8116.</b>                    2 x G53 12V 60W</p>	
<p><b>8117.</b>                    4 x G53 12V 60W</p>	

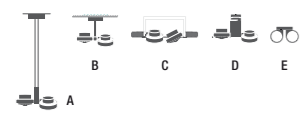

CORNER. Family / Familia  
 Pages / Páginas: A-208/210. B-277/278. C-284/286/288.  
 D-302/304. E-364/365.

CEILING LAMPS  
 PLAFONES





# Downlight Empotrables

Basik	290/292
Corner	284/286/288
Mini Marc	296
Mini Quadra	297
Sixties	294

**Corner**  
Design by Oscar & Sergi Devesa.

Chrome / Cromo.

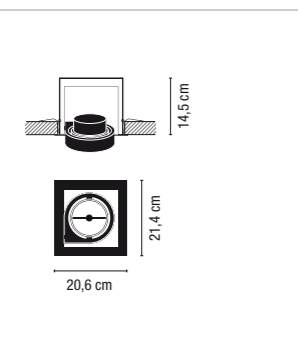
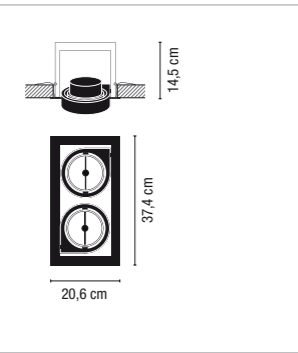
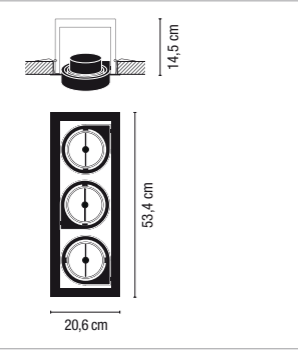
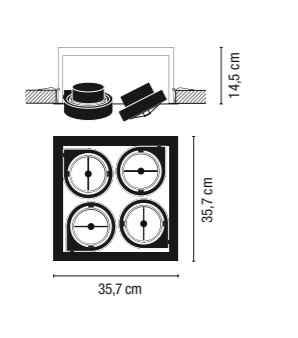
<p><b>8145.</b> 1 G53 12V 60W</p> 
<p><b>8146.</b> 2 x G53 12V 60W</p> 
<p><b>8147.</b> 3 x G53 12V 60W</p> 
<p><b>8148.</b> 4 x G53 12V 60W</p> 

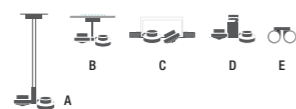

CORNER. Family / Familia  
Pages / Páginas: A-208/210. B-277/278. C-284/286/288.  
D-302/304. E-364/365.

DOWNLIGHT  
EMPOTRABLES

8145.



8146.



8147.



8148.



**Corner**

Design by Oscar & Sergi Devesa.

Chrome / Cromo.

<p><b>8140.</b>   GU 5,3 12V 50W</p> 	
<p><b>8141.</b>   2 x GU 5,3 12V 50W</p> 	
<p><b>8142.</b>   3 x GU 5,3 12V 50W</p> 	
<p><b>8143.</b>   4 x GU 5,3 12V 50W</p> 	

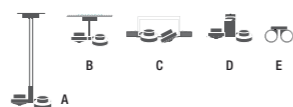

CORNER. Family / Familia  
 Pages / Páginas: A-208/210. B-277/278. C-284/286/288.  
 D-302/304. E-364/365.

8140.



8141.



8142.



8143.



DOWNLIGHT  
 EMPOTRABLES

DOWNLIGHT  
EMPOTRABLES

8149.



Ø 46 cm

**Corner**

Design by Oscar & Sergi Devesa.

Chrome / Cromo.

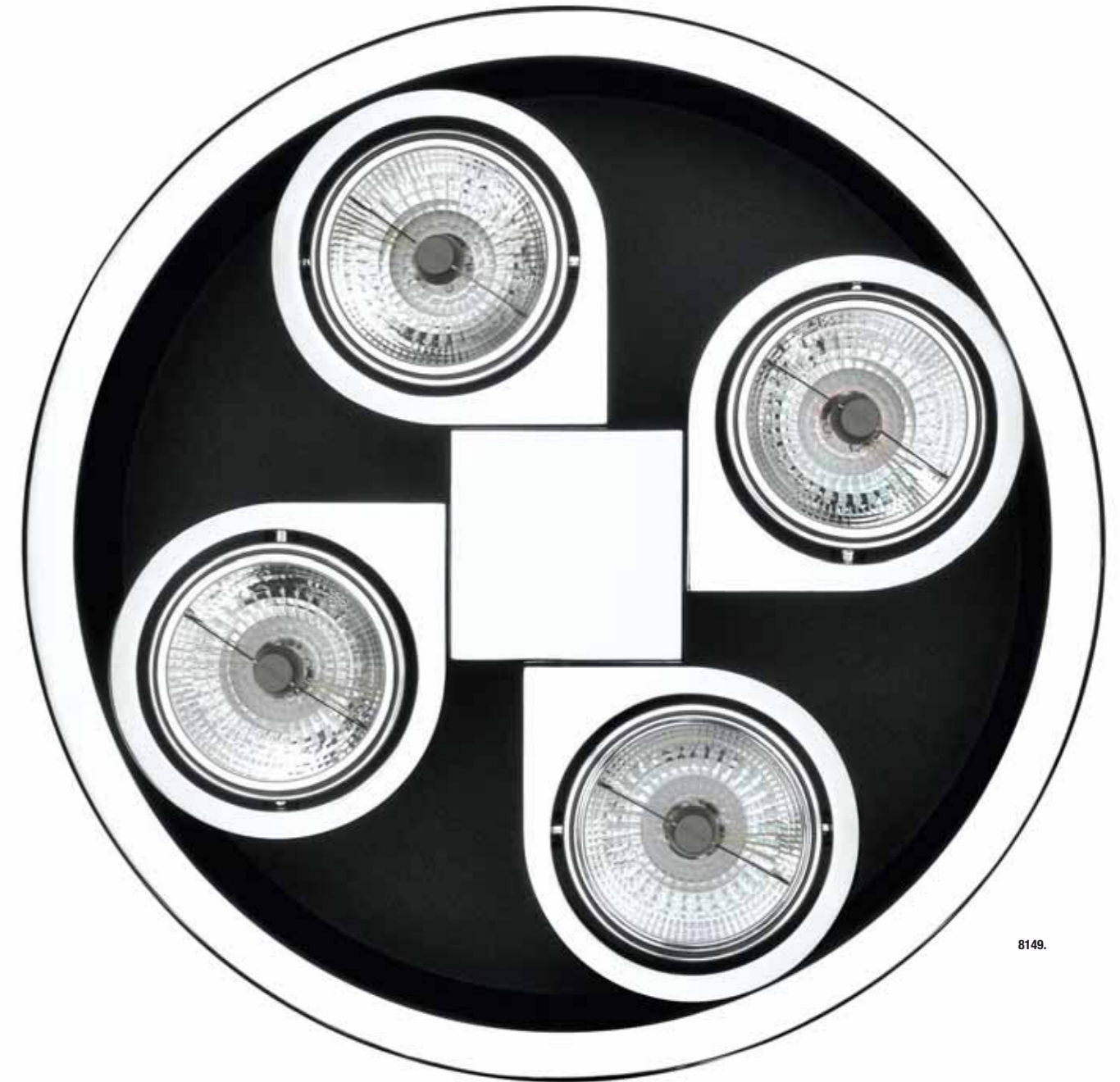

8149.

Ø 46 cm

**8144.**  
4 x GU 5,3 12V 50W  
Ø 31,1 cm  
Ø 35,5 cm  
12,5 cm

**8149.**  
4 x G53 12V 60W  
Ø 42,1 cm  
Ø 46 cm  
14 cm

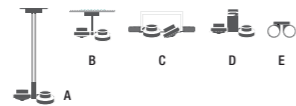

CORNER. Family / Familia  
Pages / Páginas: A-208/210. B-277/278. C-284/286/288.  
D-302/304. E-364/365.

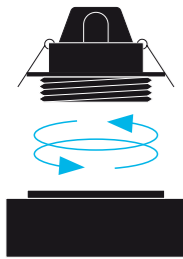

**Basik**  
Profi Diffusion Studio.

Chrome / Cromo.  
Borosilicate diffuser / Difusor de borosilicato.

<p><b>8620.</b></p> <p>G9 230V 60W Max. (OSRAM HALOPIN)</p> <p>Ø 6,7 cm</p>	<p>8,6 cm</p> <p>9 cm</p> <p>9 cm</p>	<p>5 cm</p>
<p><b>8622.</b></p> <p>G9 230V 60W Max. (OSRAM HALOPIN)</p> <p>Ø 6,7 cm</p>	<p>8,6 cm</p> <p>11 cm</p> <p>11 cm</p>	<p>5 cm</p>



DOWNLIGHT  
EMPOTRABLES

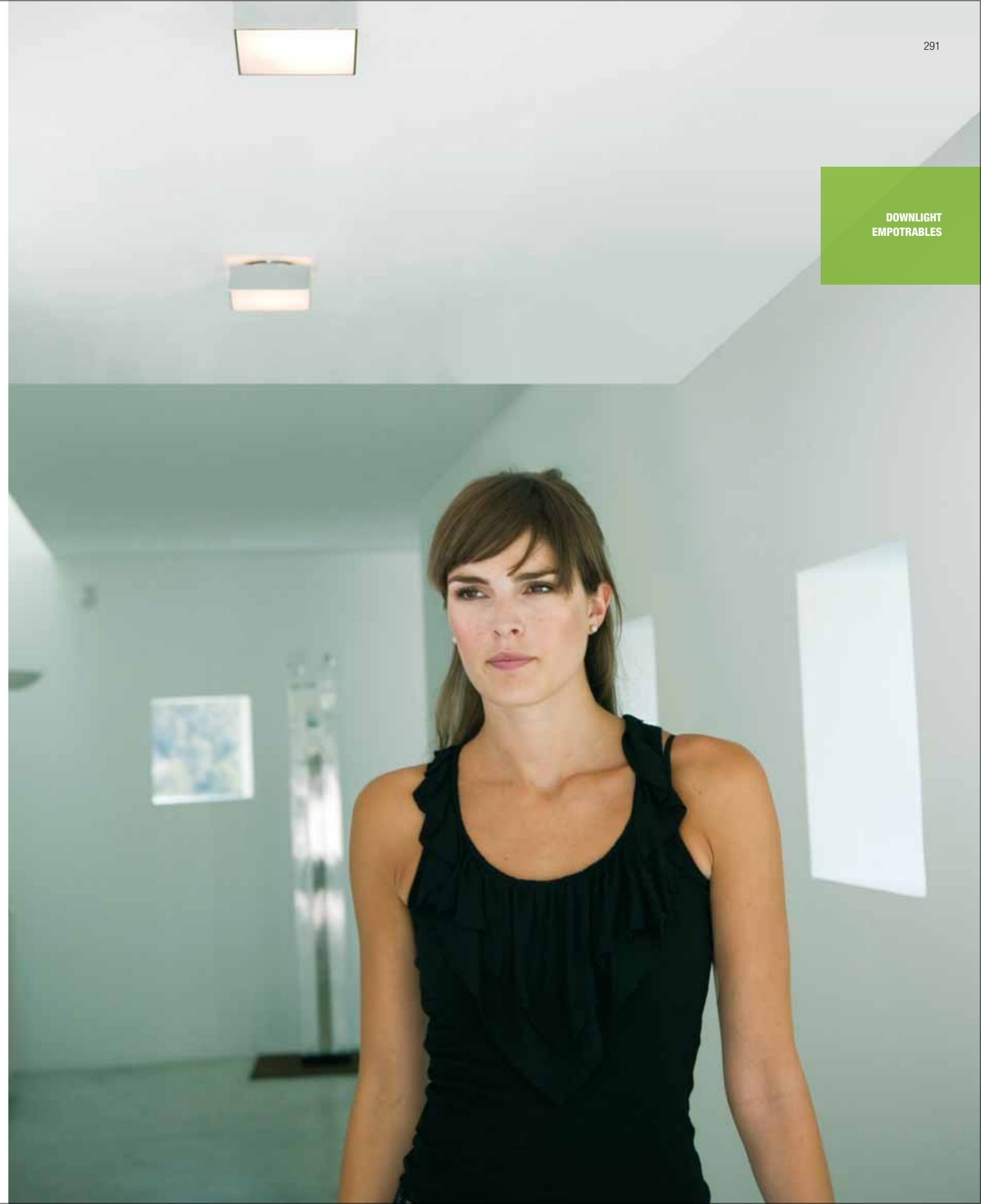

**Basik**  
Proli Diffusion Studio.

Chrome / Cromo.  
Borosilicate diffuser / Difusor de borosilicato.



<p><b>8621.</b></p> <p>G9 230V 60W Max. (OSRAM HALOPIN)</p> <p>Ø 6,7 cm</p>	
<p><b>8623.</b></p> <p>G9 230V 60W Max. (OSRAM HALOPIN)</p> <p>Ø 6,7 cm</p>	

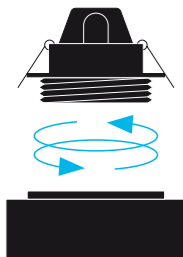

DOWNLIGHT  
EMPOTRABLES



**Sixties**  
Design by Margarita Viarnés.

Chrome and white porcelain /  
Cromo y porcelana blanca.

8938.



**8938.**  
G53 12V 75W  
Ø 11 cm

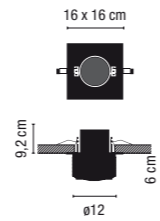

8939.



**8932.**  
GU 5,3 12V 50W  
Ø 11 cm

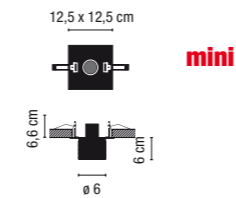

**mini**

8932.



Matt nickel and black porcelain /  
Níquel mate y porcelana negra.

**8939.**  
G53 12V 75W  
Ø 11 cm

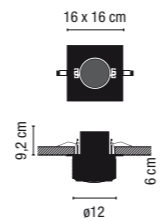

**mini**

8933.



**8933.**  
GU 5,3 12V 50W  
Ø 11 cm

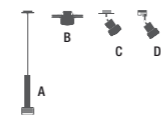
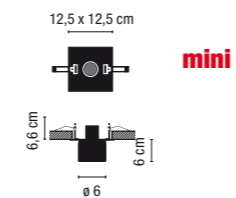

SIXTIES. Family / Familia  
Pages / Páginas: A-196. B-294. C-323/329. D-329.

DOWNLIGHT  
EMPOTRABLES

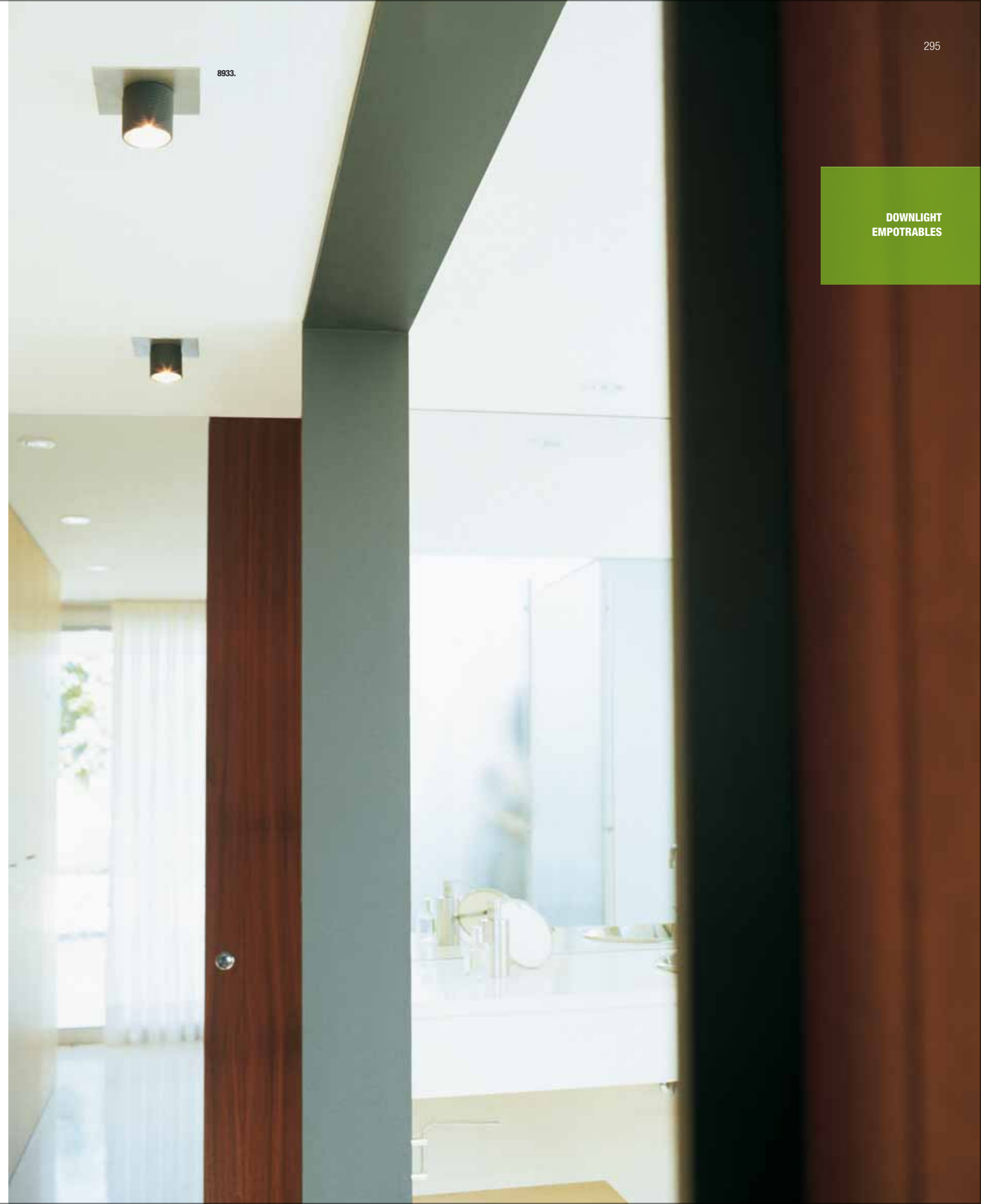

**Mini Marc**

Design by Prolif Diffusion Studio.

Chrome, matt nickel / Cromo, níquel mate.  
Optical glass diffuser / Difusor de vidrio óptico.

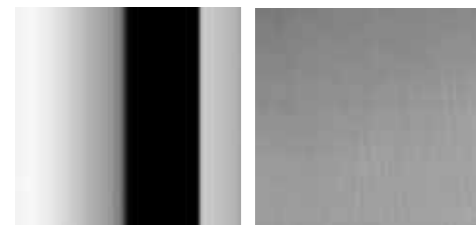
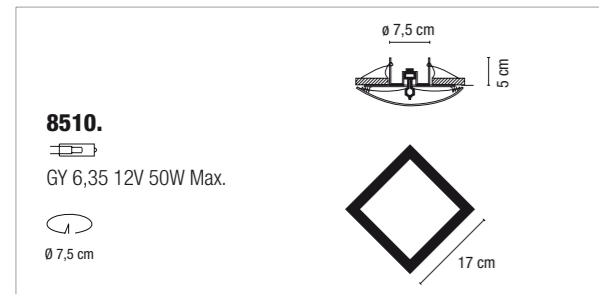

Chrome / Cromo. Matt nickel / Níquel mate.



**Mini Quadra**

Design by Prolif Diffusion Studio.

Optical glass diffuser / Difusor de vidrio óptico.

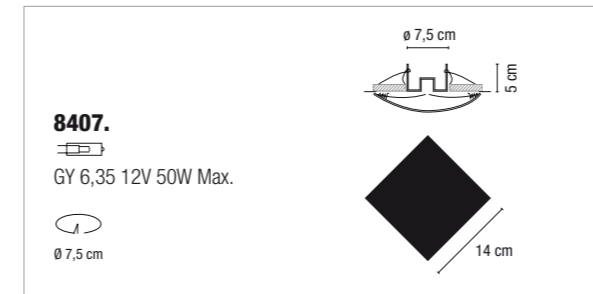



# Spots

Corner	302/304
Sixties	323/325/326/329
Soft	314/318/320
Stage	308/310

SPOTS

**Corner**  
Design by Oscar & Sergi Devesa.

Chrome / Cromo.



<p><b>8135.</b> G53 12V 60W</p>	
<p><b>8136.</b> 2 x G53 12V 60W</p>	

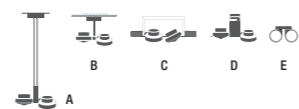

CORNER. Family / Familia  
Pages / Páginas: A-208/210. B-277/278. C-284/286/288.  
D-302/304. E-364/365.

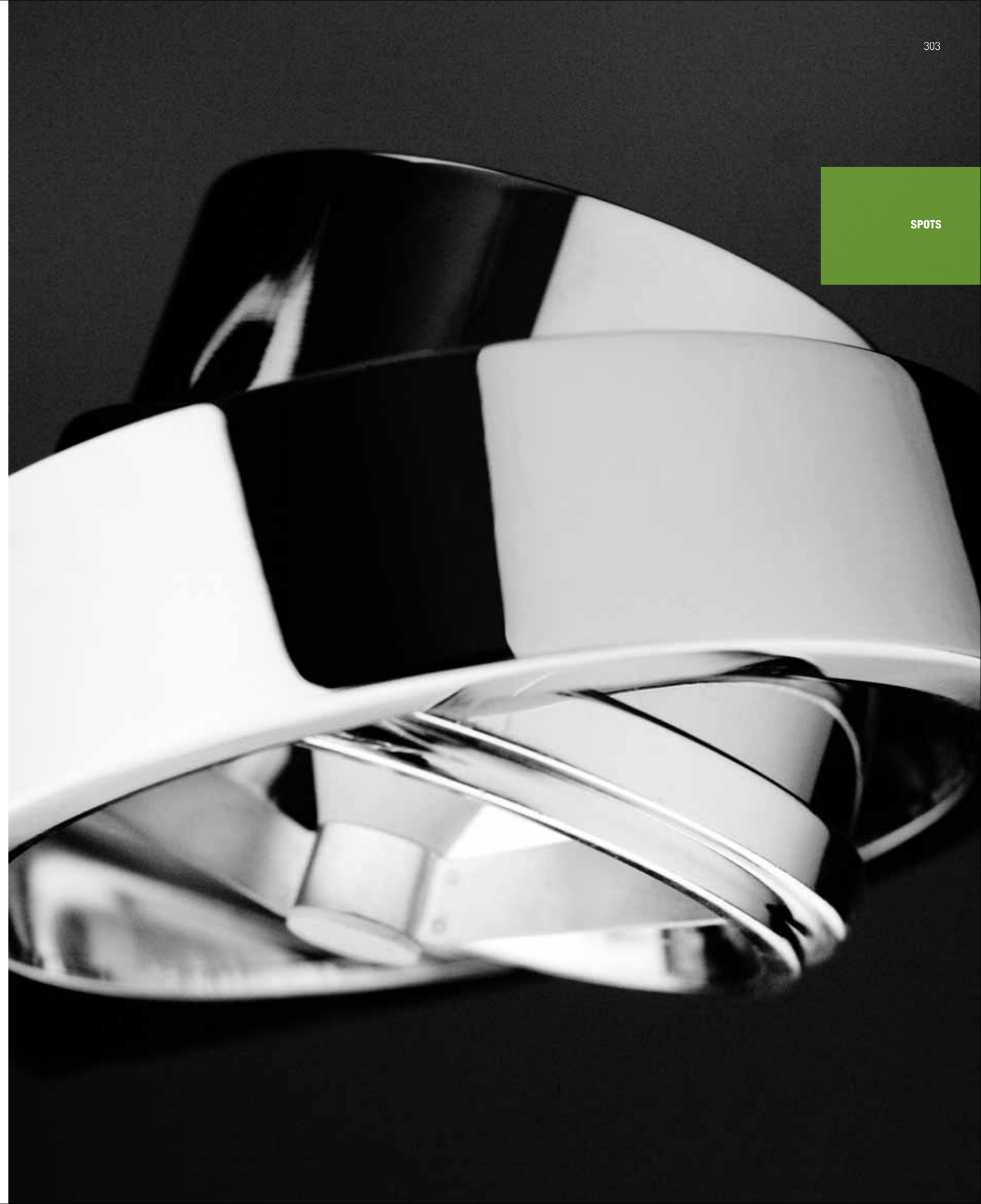

**Corner**  
Design by Oscar & Sergi Devesa.

Chrome / Cromo.



8130.



8131.

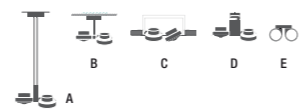
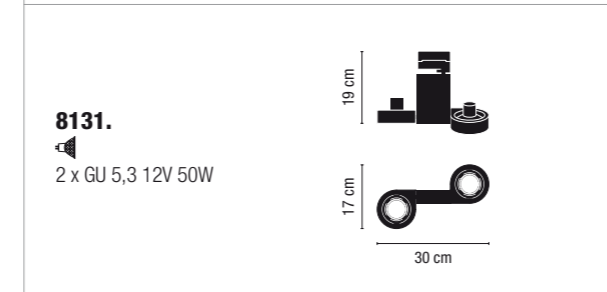
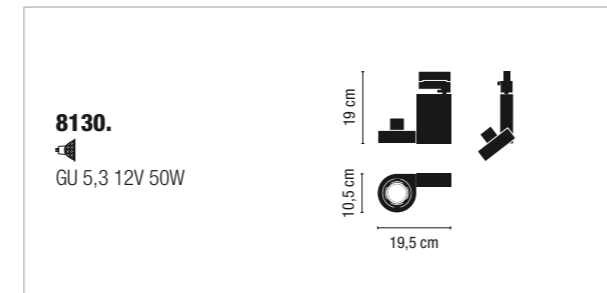

CORNER. Family / Familia  
Pages / Páginas: A-208/210. B-277/278. C-284/286/288.  
D-302/304. E-364/365.



SPOTS



8970-01.



8980-03.



8971-01.



8981-03.



### Stage

Design by X. Claramunt and M. de Mas.

Chrome, white lacquer /  
Cromo, lacado blanco.

#### 8970.

E-27 Par Halógena  
230V 100W

#### 8980.

G53 12V 60W

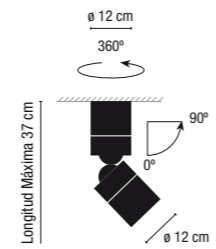

#### 8971.

E-27 Par Halógena  
230V 100W

#### 8981.

G53 12V 60W

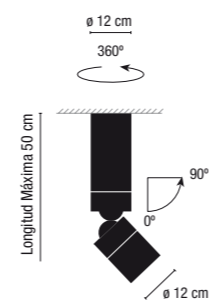

**Stage**

Design by X. Claramunt and M. de Mas.

Chrome and white lacquer /  
Cromo y lacado blanco.

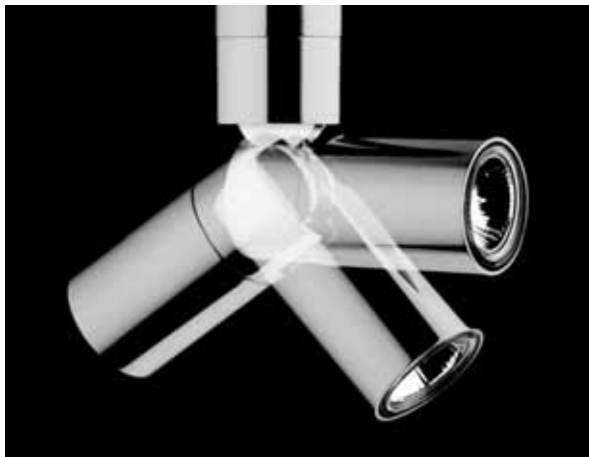
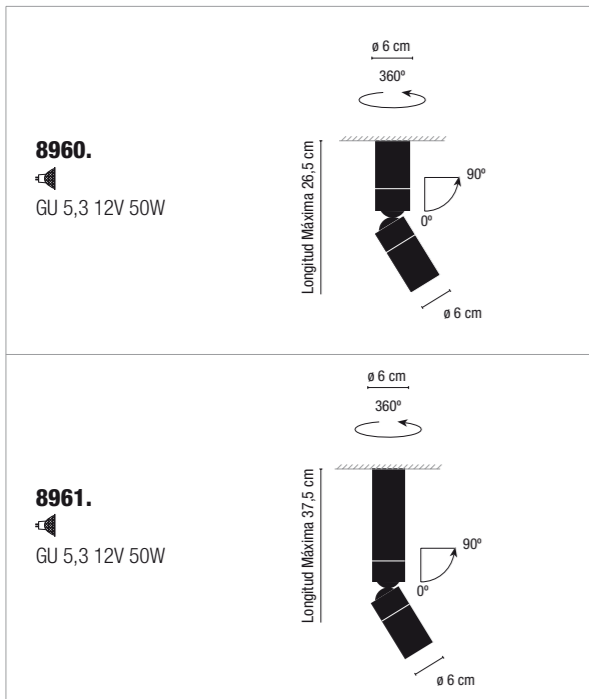

8960-01.



8960-03.



8961-01.



8961-03.



SPOTS

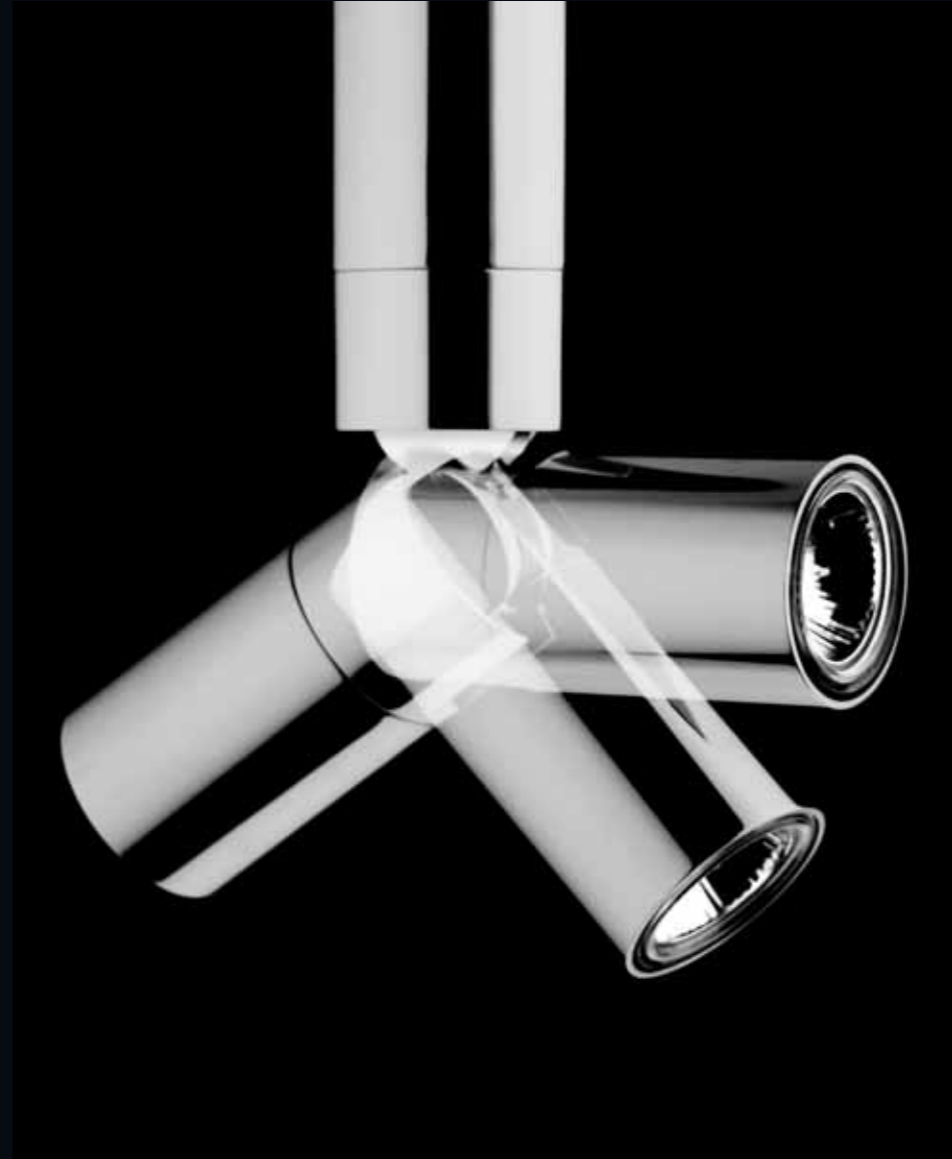

**Soft**  
Design by X. Claramunt & M. de Mas.

Chrome, matt nickel / Cromo, níquel mate.

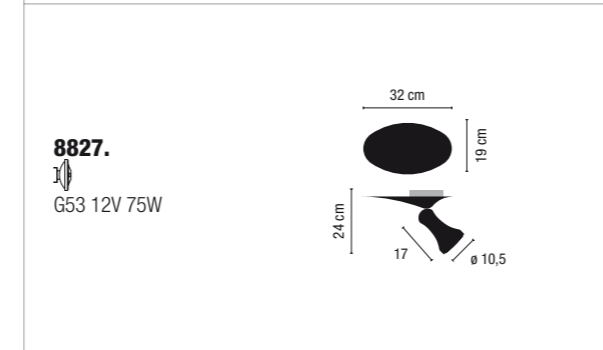
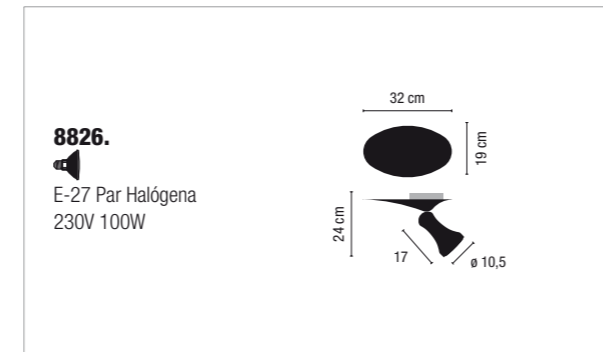
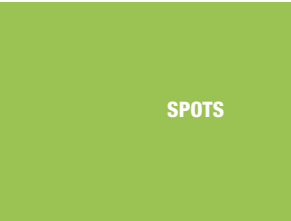

**mini**

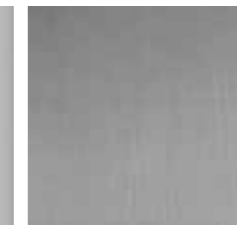
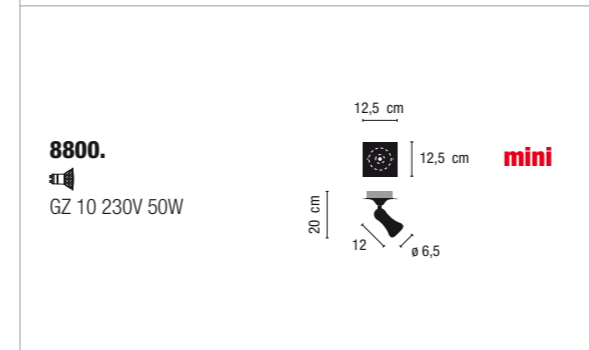
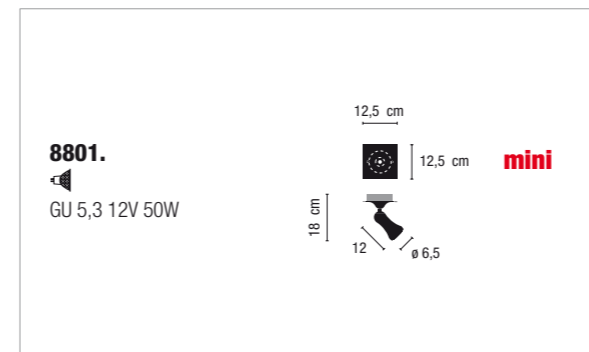
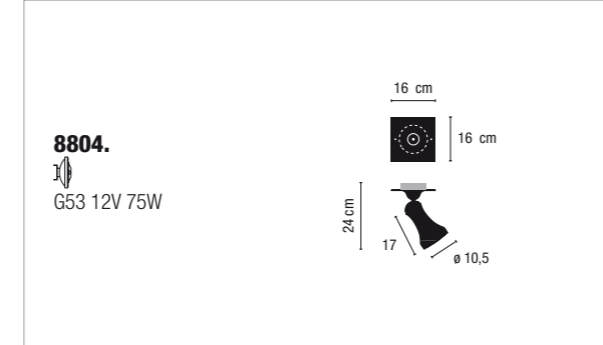
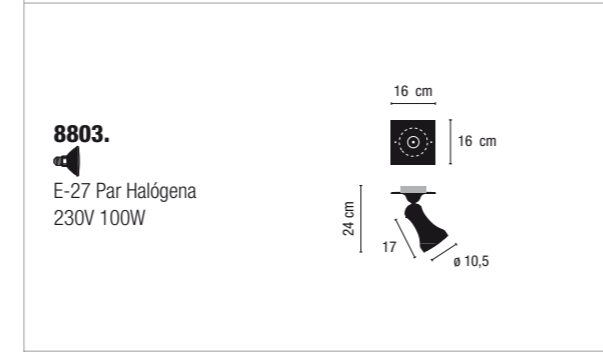

Chrome / Cromo.

Matt nickel / Níquel mate.

**Installation.**

Each individual spot is supplied with its case. Each square-base spot can be surface (Fig.1) or built-in (Fig. 2) installed. In case of a built-in installation, it is possible to use a special ring (ref. 8895, to be bought separately) of 13 cm diameter or (ref. 8896, to be bought separately) of 10,5 cm diameter (Fig. 3).

**Instalación.**

Cada referencia de spot individual incluye tanto el spot como la caja posterior. El spot de florón cuadrado puede ser instalado en superficie (Fig. 1) o empotrando la caja (Fig. 2) o adquiriendo adicionalmente un aro circular de empotrar (Ref. 8895) de 13 cm o (Ref. 8896) de 10,5 cm (Fig. 3). Para empotrar los spots de florón circular se debe adquirir adicionalmente un aro circular de empotrar (Ref. 8895) de 13 cm o (Ref. 8896) de 10,5 cm (Fig. 3).

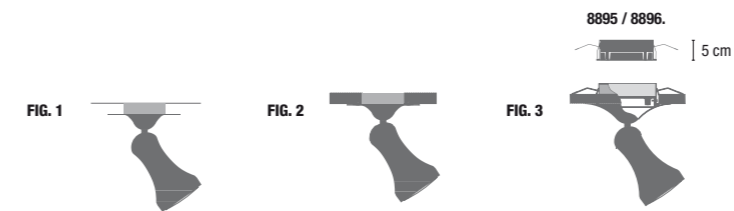





SPOTS

**Soft**  
Design by Proli Diffusion Studio.

Chrome, matt nickel / Cromo, níquel mate.

8990. + (2 x 8803.)



**8990.**  
Two-spot installation case / Caja anclaje de dos spots.

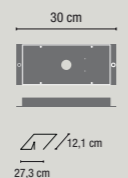

**8991.**  
Three-spot installation case / Caja anclaje de tres spots.

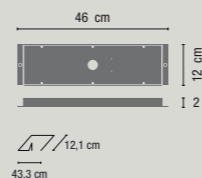

**8992.**  
Four-spot installation case / Caja anclaje de cuatro spots.

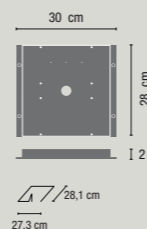

**8993.**  
Two-spot installation case / Caja anclaje de dos spots.

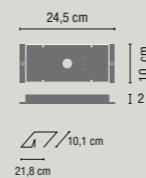

**8994.**  
Three-spot installation case / Caja anclaje de tres spots.

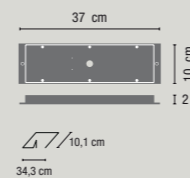

**8995.**  
Four-spot installation case / Caja anclaje de cuatro spots.



8991. + (3 x 8803.)



8992. + (4 x 8803.)



**2 x 8803.**

E-27 Par Halógena  
230V 100W

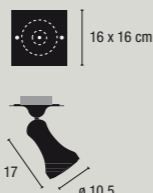

**3 x 8803.**

E-27 Par Halógena  
230V 100W

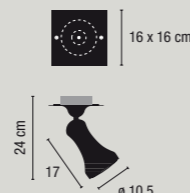

**4 x 8803.**

E-27 Par Halógena  
230V 100W

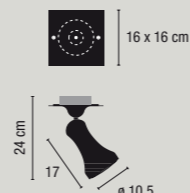

**2 x 8804.**

G53 12V 75W

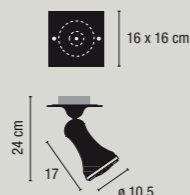

**3 x 8804.**

G53 12V 75W

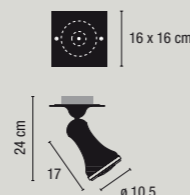

**4 x 8804.**

G53 12V 75W

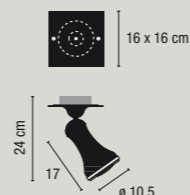

**2 x 8801.**

GU 5,3 12V 50W



**3 x 8801.**

GU 5,3 12V 50W



**4 x 8801.**

GU 5,3 12V 50W



**2 x 8800.**

GZ 10 230V 50W



**3 x 8800.**

GZ 10 230V 50W



**4 x 8800.**

GZ 10 230V 50W

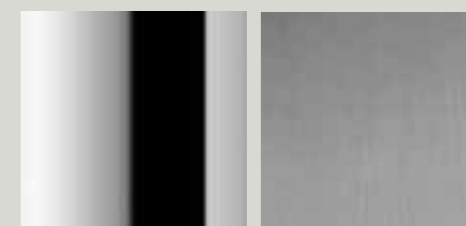

Chrome / Cromo.

Matt nickel / Níquel mate.

**Installation.**

All spots are sold by single unit. For a multiple-base installation, you will need the sufficient quantity of spots and the corresponding case (Ref. 8990, 8991 or 8992).

**Instalación.**

Cada spot se suministra individualmente. Para instalar bases múltiples, se debe adquirir la cantidad de spots necesarios y, adicionalmente la caja base correspondiente (Ref. 8990, 8991 o 8992).

**Installation.**

All spots are sold by single unit. For a multiple-base installation, you will need the sufficient quantity of spots and the corresponding case (Ref. 8993, 8994 or 8995).

**Instalación.**

Cada spot se suministra individualmente. Para instalar bases múltiples, se debe adquirir la cantidad de spots necesarios y, adicionalmente la caja base correspondiente (Ref. 8993, 8994 o 8995).



**Soft**  
Design by X. Claramunt & M. de Mas.

Chrome, matt nickel / Cromo, níquel mate.

<p><b>8842.</b> E-27 Par Halógena 230V 100W</p>	
<p><b>8843.</b> G53 12V 75W</p>	

<p><b>8841.</b> GU 5,3 12V 50W</p>	<p><b>mini</b></p>
<p><b>8840.</b> GZ 10 230V 50W</p>	<p><b>mini</b></p>

All spots are sold by single unit, each one complete with its three-phase track adapter (mod. GLOBAL). Tracks are not supplied. / Cada spot se suministra individualmente con su adaptador a carril trifásico (mod. GLOBAL). No se suministran carriles.

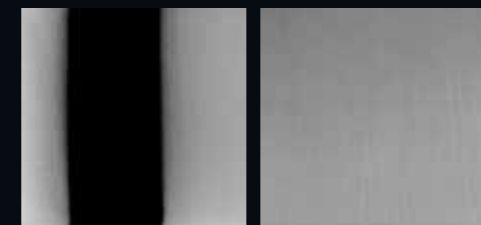

Chrome / Cromo.

Matt nickel / Níquel mate.



**SPOTS**

SIXTIES, 8906.

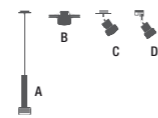

SIXTIES. Family / Familia  
Pages / Páginas: A-196. B-294. C-323/329. D-329.

**Sixties**  
Design by Margarita Viarnés.

Chrome and white porcelain /  
Cromo y porcelana blanca.

Matt nickel and black porcelain /  
Niquel mate y porcelana negra.

**8906.**  
E-27 Par Halógena  
230V 100W

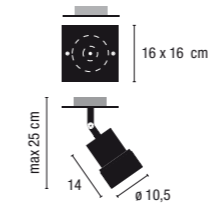

**8908.**  
G53 12V 75W

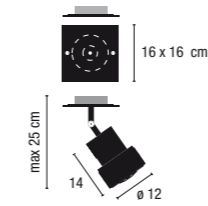

**8907.**  
E-27 Par Halógena  
230V 100W

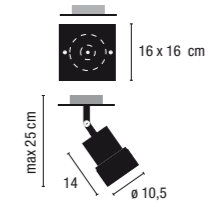

**8909.**  
G53 12V 75W

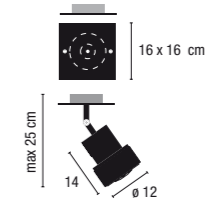

**Installation.**

Each individual spot is supplied with its case. Each spot can be surface (Fig.1) or built-in (Fig. 2) installed. In case of a built-in installation, it is possible to use a special ring (ref. 8895, to be bought separately) of 13 cm diameter (Fig. 3).

**Instalación.**

Cada referencia de spot individual incluye tanto el spot como la caja posterior. Cada spot puede ser instalado en superficie (Fig. 1) o empotrando la caja (Fig. 2). Si se desea empotrar la caja, se puede adquirir adicionalmente un aro circular de empotrar (ref. 8895) de 13 cm (Fig. 3).

FIG. 1

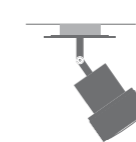

FIG. 2

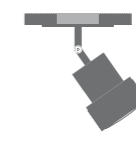
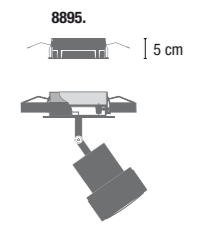

FIG. 3





SPOTS

**Sixties**  
Design by Margarita Viarnés.

Chrome and white porcelain /  
Cromo y porcelana blanca.

Matt nickel and black porcelain /  
Niquel mate y porcelana negra.



**8902.**  
GU 5,3 12V 50W

**8900.**  
GZ 10 230V 50W

**8903.**  
GU 5,3 12V 50W

**8901.**  
GZ 10 230V 50W



**Installation.**

Each individual spot is supplied with its case. Each spot can be surface (Fig. 1) or built-in (Fig. 2) installed. In case of a built-in installation, it is possible to use a special ring (ref. 8896, to be bought separately) of 10,5 cm diameter (Fig. 3).

**Instalación.**

Cada referencia de spot individual incluye tanto el spot como la caja posterior. Cada spot puede ser instalado en superficie (Fig. 1) o empotrando la caja (Fig. 2). Si no se desea empotrar la caja, se puede adquirir adicionalmente un aro circular de empotrar (Ref. 8896) de 10,5 cm (Fig. 3).

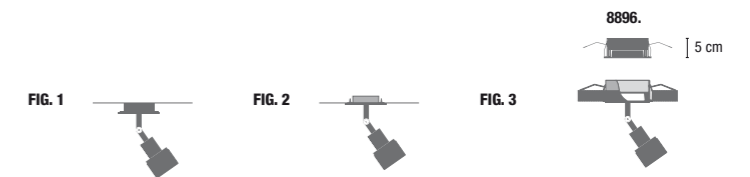
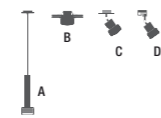

**Sixties**

Design by Margarita Viarnés.

Chrome, matt nickel / Cromo, níquel mate.

**Mini Sixties**

Design by Margarita Viarnés.

Chrome, matt nickel / Cromo, níquel mate.

8990. + (2 x 8909.)



8991. + (3 x 8908.)



8992. + (4 x 8909.)

**8990.**

Two-spot installation case / Caja anclaje de dos spots.

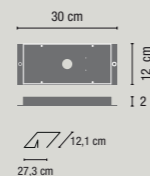
**8991.**

Three-spot installation case / Caja anclaje de tres spots.

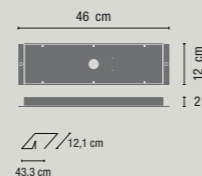
**8992.**

Four-spot installation case / Caja anclaje de cuatro spots.

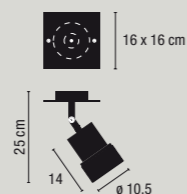
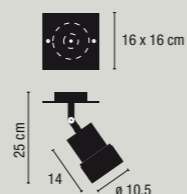
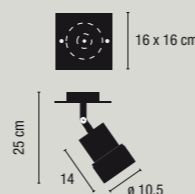
**2 x 8906.  
2 x 8907.**E-27 Par Halógena  
230V 100W**3 x 8906.  
3 x 8907.**E-27 Par Halógena  
230V 100W**4 x 8906.  
4 x 8907.**E-27 Par Halógena  
230V 100W**2 x 8908.  
2 x 8909.**

G53 12V 75W

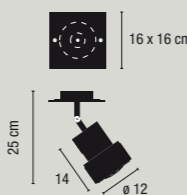
**3 x 8908.  
3 x 8909.**

G53 12V 75W

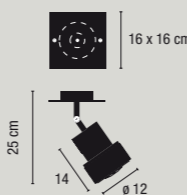
**4 x 8908.  
4 x 8909.**

G53 12V 75W

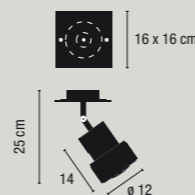
**8993.**

Two-spot installation case / Caja anclaje de dos spots.

**8994.**

Three-spot installation case / Caja anclaje de tres spots.

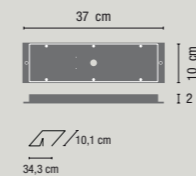
**8995.**

Four-spot installation case / Caja anclaje de cuatro spots.

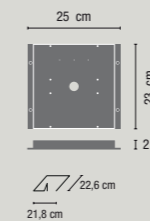
**2 x 8902.  
2 x 8903.**

GU 5,3 12V 50W

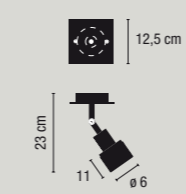
**3 x 8902.  
3 x 8903.**

GU 5,3 12V 50W

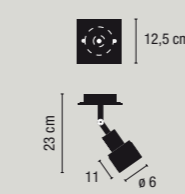
**4 x 8902.  
4 x 8903.**

GU 5,3 12V 50W

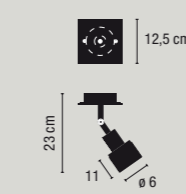
**2 x 8900.  
2 x 8901.**

GZ 10 230V 50W

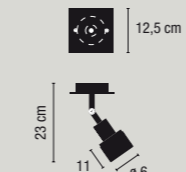
**3 x 8900.  
3 x 8901.**

GZ 10 230V 50W

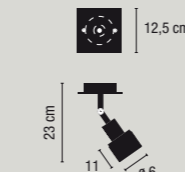
**4 x 8900.  
4 x 8901.**

GZ 10 230V 50W

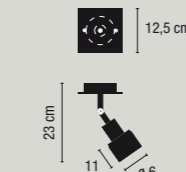
**Installation.**

All spot are sold by single unit. For a multiple-base installation, you will need the sufficient quantity of spots and the corresponding case (Ref. 8990, 8991 or 8992).

**Instalación.**

Cada spot se suministra individualmente. Para instalar bases múltiples, se debe adquirir la cantidad de spots necesarios y, adicionalmente la caja base correspondiente (Ref. 8990, 8991 o 8992).

**Installation.**

All spot are sold by single unit. For a multiple-base installation, you will need the sufficient quantity of spots and the corresponding case (Ref. 8993, 8994 or 8995).

**Instalación.**

Cada spot se suministra individualmente. Para instalar bases múltiples, se debe adquirir la cantidad de spots necesarios y, adicionalmente la caja base correspondiente (Ref. 8993, 8994 o 8995).

SPOTS

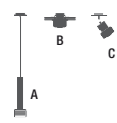



SPOTS

**Sixties**  
Design by Margarita Viarnés.



8924



8925



mini

8920



mini

8921

**8924.** Chrome and white porcelain / Cromo y porcelana blanca.  
**8925.** Matt nickel and black porcelain / Niquel mate y porcelana negra.



E-27 Par Halógena  
230V 100W

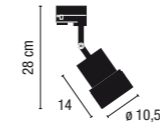

**8926.** Chrome and white porcelain / Cromo y porcelana blanca.  
**8927.** Matt nickel and black porcelain / Niquel mate y porcelana negra.



G53 12V 75W

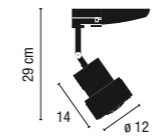

**8922.** Chrome and white porcelain / Cromo y porcelana blanca.  
**8923.** Matt nickel and black porcelain / Niquel mate y porcelana negra.



GU 5,3 12V 50W

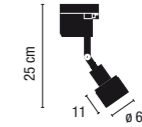

mini

**8920.** Chrome and white porcelain / Cromo y porcelana blanca.  
**8921.** Matt nickel and black porcelain / Niquel mate y porcelana negra.



GZ 10 230V 50W

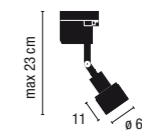

mini

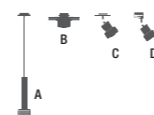

SIXTIES. Family / Familia  
Pages / Páginas: A-196. B-294. C-323/329. D-329.

All spots are sold by single unit, each one complete with its three-phase track adapter (mod. GLOBAL). Tracks are not supplied. / Cada spot se suministra individualmente con su adaptador a carril trifásico (mod. GLOBAL). No se suministran carriles.



## **Picture Light Iluminacuadros**

<b>Barcel'art</b>	<b>343</b>
<b>Da Vinci</b>	<b>340</b>
<b>Flauta</b>	<b>338</b>
<b>Gugen'art</b>	<b>335</b>





**Gugen'art**  
Design by Prolif Diffusion Studio.

Matt nickel / Níquel mate.

**5300.**

FM 6W (OSRAM T2).

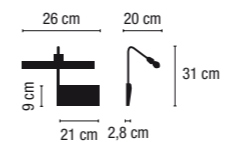

**5310.**

2 x G4 12V 20W Max.

**5302.**

FM 11W (OSRAM T2).

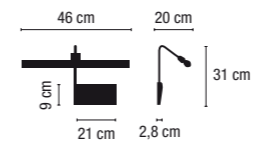

**5303.**

FM 13W (OSRAM T2).

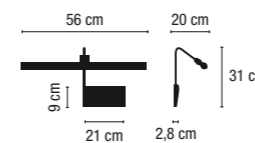

**5301.**

FM 8W (OSRAM T2).

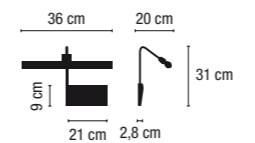

**5311.**

2 x G4 12V 20W.

**5312.**

3 x G4 12V 20W Max.

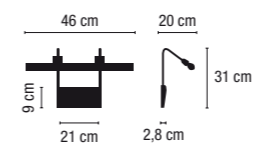

**5313.**

3 x G4 12V 20W.

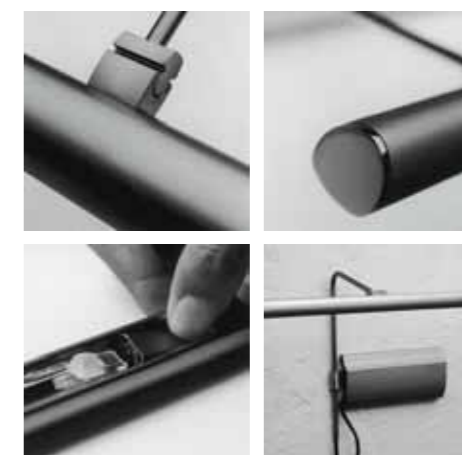
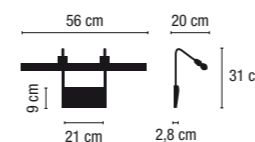

PICTURE LIGHT  
ILUMINACUADROS









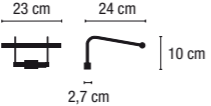

PICTURE LIGHT  
ILUMINACUADROS

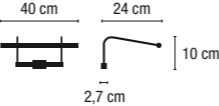
**Flauta**  
Design by Proli Diffusion Studio.

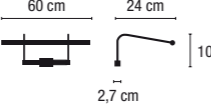
Shiny and satin brass combined,  
shiny and satin chrome combined /  
Dorado mate y brillo combinado,  
cromo mate y brillo combinado.

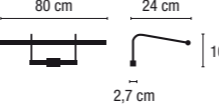
<p><b>1015.</b>  2 x GY 6,35 12V 20W Max.</p> 	<p><b>1016.</b>  2 x GY 6,35 12V 20W Max.</p> 
<p><b>1017.</b>  4 x GY 6,35 12V 20W Max.</p> 	<p><b>1018.</b>  4 x GY 6,35 12V 20W Max.</p> 

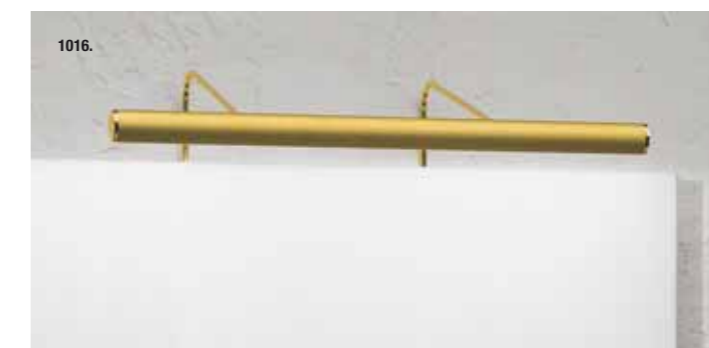



PICTURE LIGHT  
ILUMINACUADROS

**Da Vinci**  
Design by Prolif Diffusion Studio.

Shiny and satin chrome combined /  
Cromo mate y brillo combinado.

**1025.**

FM 6W (OSRAM T2).

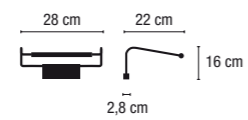

**1026.**

FM 8W (OSRAM T2).

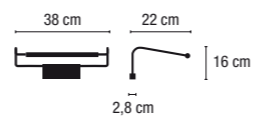

**1027.**

FM 11W (OSRAM T2).

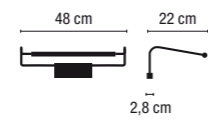

**1028.**

FM 13W (OSRAM T2).

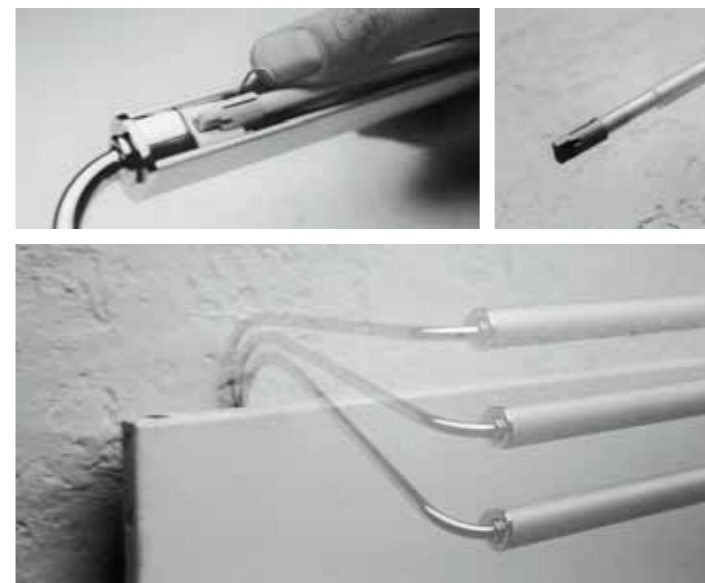
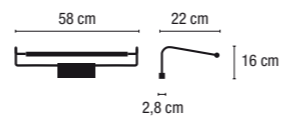



**Barcel'art**  
Design by Proli Diffusion Studio.

Satin gold, matt nickel /  
Baño oro brossé, níquel mate.

**1033.**

E14 Tubular 40W

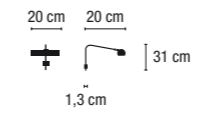

**1034.**

2 x E14 Tubular 40W.

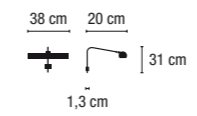

**1035.**

2 x E14 Tubular 40W.

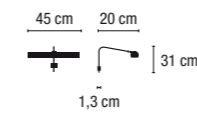

**1036.**

3 x E14 Tubular 40W.

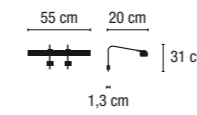

**1037.**

4 x E14 Tubular 40W.

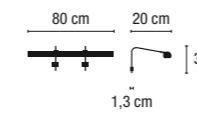



## Bath Lamps Baño

Linestra	358
Llisa	354/357
Look	351/353
Millenium	349

**Millenium**

Design by Ramons &amp; Bassols.

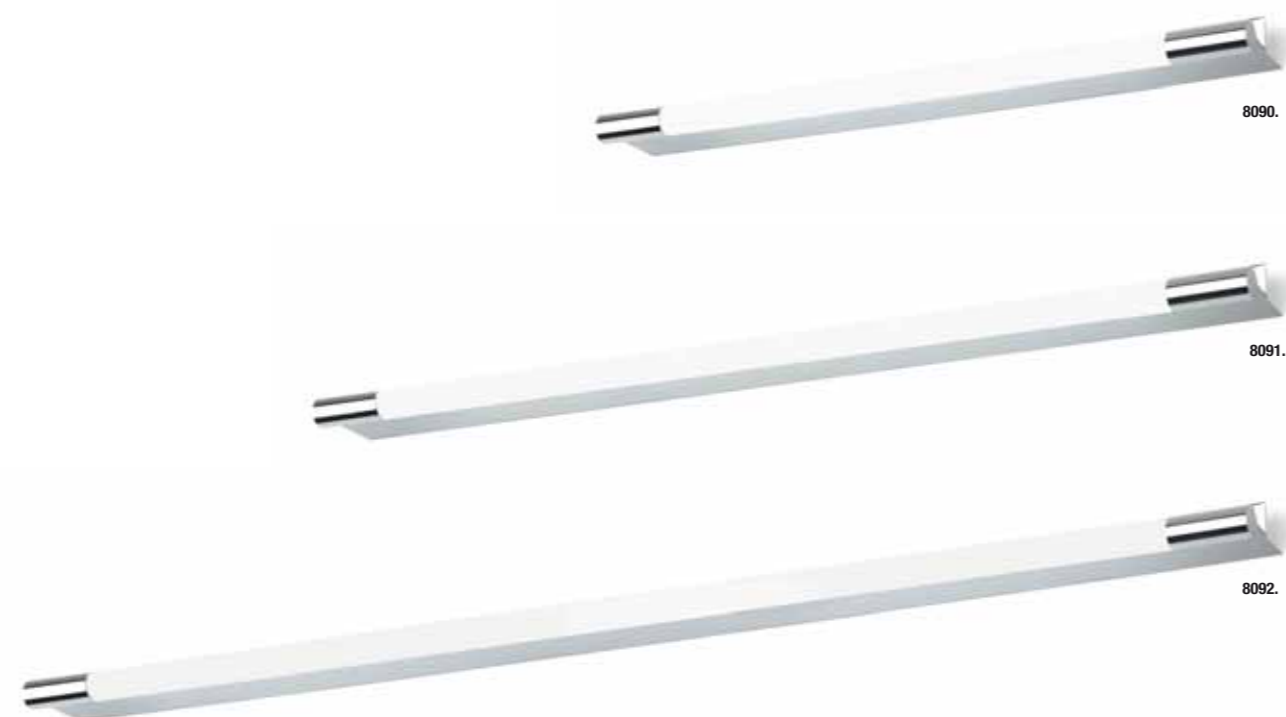
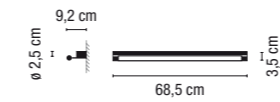
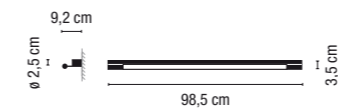
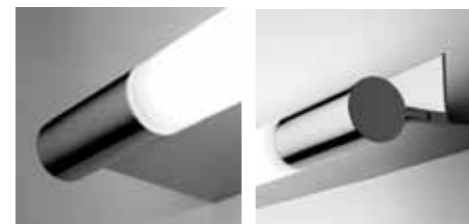
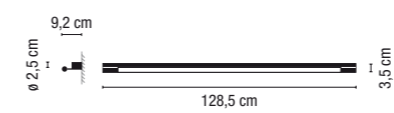
Chrome / Cromo.  
Polycarbonate diffuser /  
Difusor de policarbonato.**8090.**  
G5 24W (T5)**8091.**  
G5 39W (T5)**8092.**  
G5 54W (T5)

**Look**  
Design by Proli Diffusion Studio.

IP43

Matt stainless steel, shiny stainless steel,  
/ Acero inoxidable brillo, acero inoxidable mate.  
Methacrylate diffuser / Difusor de metacrilato.

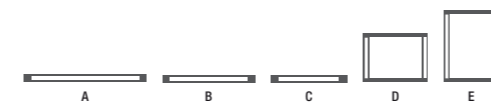
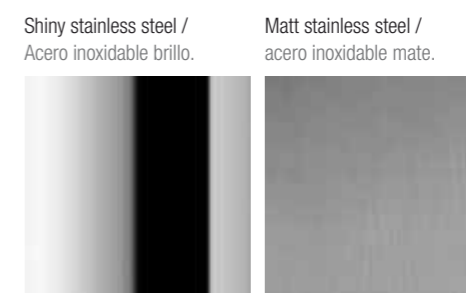
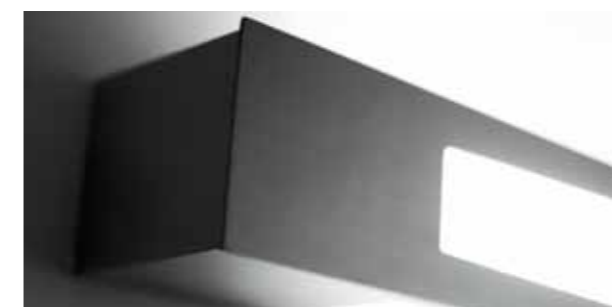
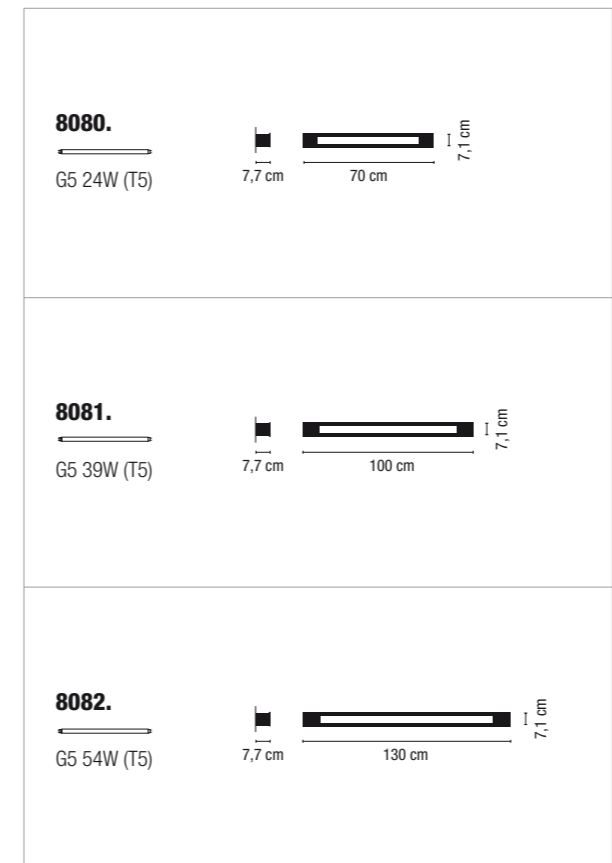
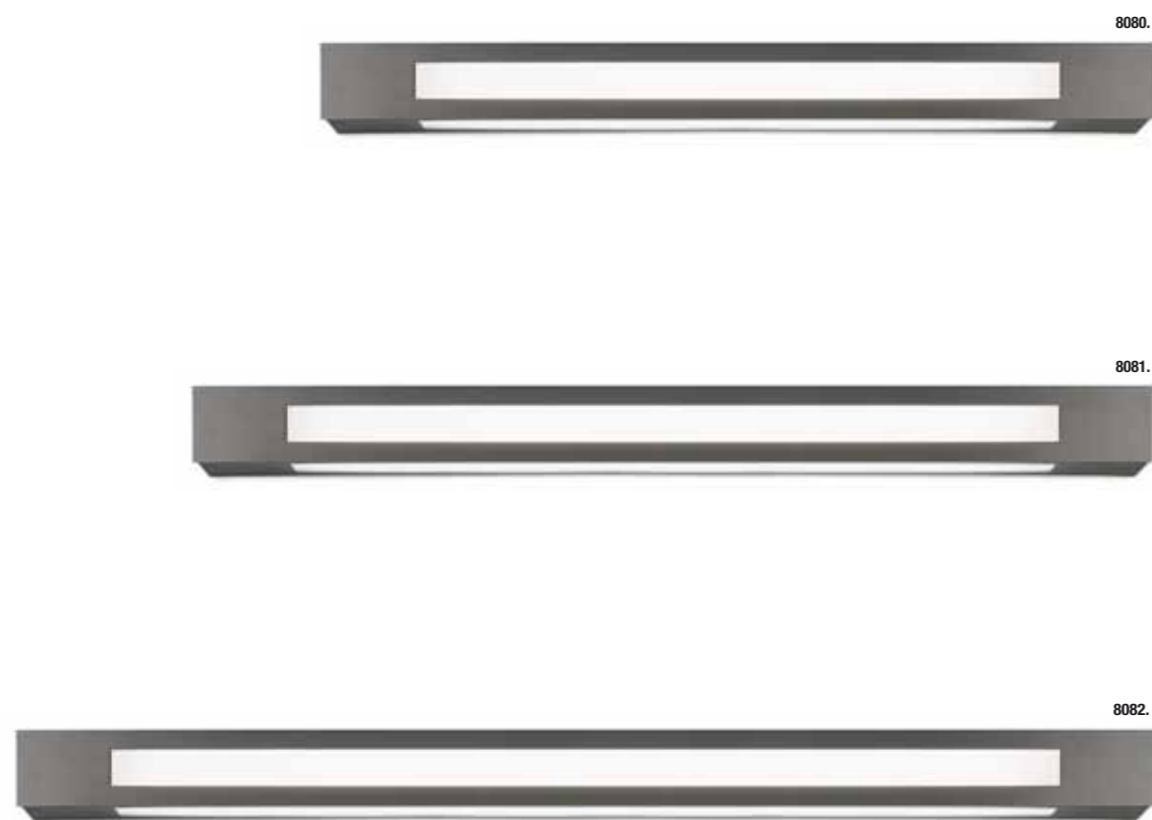





**Look**  
Design by Proli Diffusion Studio.

Stainless steel / Acero inoxidable.  
Methacrylate diffuser / Difusor de metacrilato.

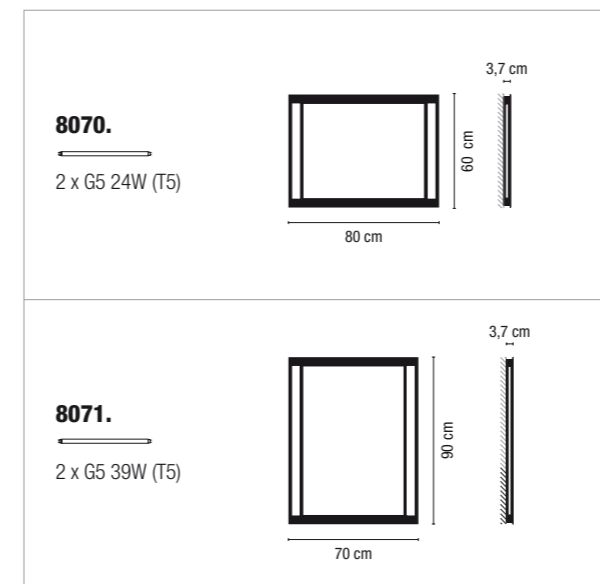

LOOK. Family / Familia  
Pages / Páginas: A-351. B-351. C-351. D-353. E-353.

**Lisa**  
Design by Proli Diffusion Studio.

IP43

Optical glass diffuser / Difusor de vidrio óptico.  
Chrome / Cromo.

**8032.**

G5 24W (T5)

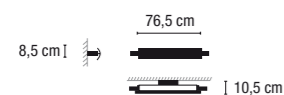
**8033.**

G5 39W (T5)

**8034.**

G5 54W (T5)

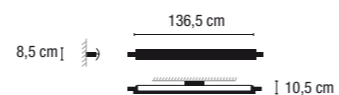

8034.

BATH LAMPS  
BAÑO



8034.



**Mini Lisa**  
Design by Prolif Diffusion Studio.

IP43

Chrome / Cromo.  
Optical glass diffuser / Difusor de vidrio óptico.

**8038.**  
G23 11W Max.

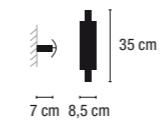



8030.

BATH LAMPS  
BAÑO



8031.

**Linestra**  
Design by Proli Diffusion Studio.

Chrome, matt nickel / Cromo, níquel mate.

**8030.**

S14d 35W: **30 cm.**

S14s 60W: **50 cm.**

S14s 120W: **100 cm.**

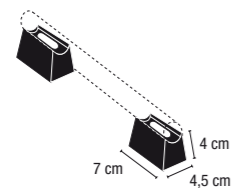

**8031.**

S14d 35W: **30 cm.**

S14d 60W: **50 cm.**



## Wall Lamps Apliques

Aina	426
Arms Biluz	438
Basik	417
Corner	364/365
Cross	420
Diva	434/436
Funnel	370/375
Lollipop	430
Mini Quadra	390
Mini Sandwich	395
Mini Sandwich Glass	397
Mini Top	403
Ona	412
Pad	378
Quadra Ice	390
Scotch	404/406
Shell	419
Signal	399
Sinuosa	414
Slim	432
Soho	400
Swing	440/444
Tatiana	428
Te	410/425
Tecto	383/384/386/388
Tulip	422
Watch	393
Zero	408



8100.



8101.

**Corner**

Design by Oscar & Sergi Devesa.

Chrome / Cromo.

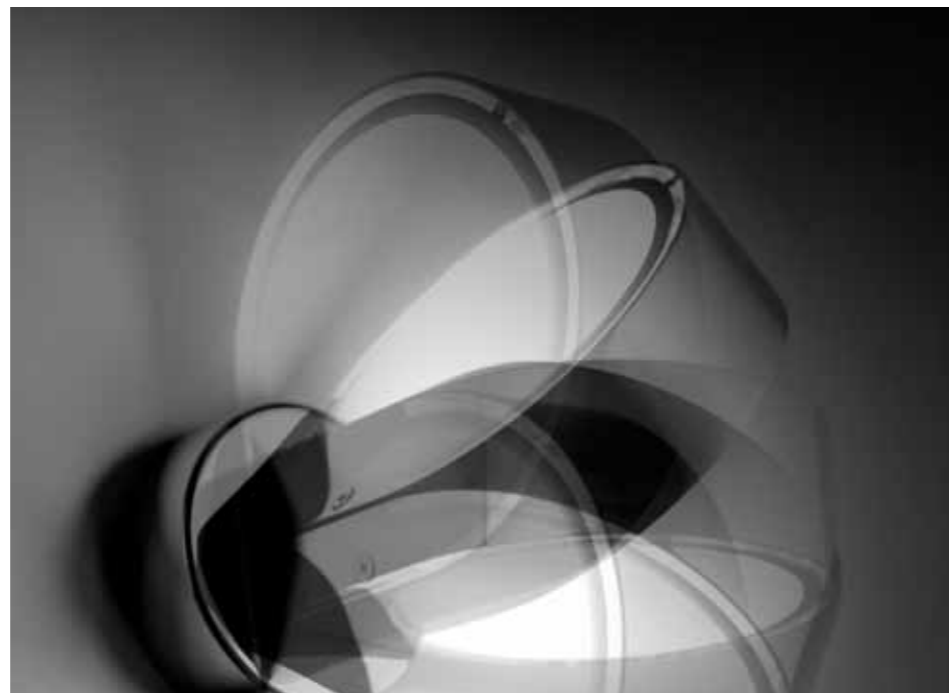

**8100.**

G9 230V 40W Max.  
(OSRAM HALOPIN)



12 cm

**Corner**

Design by Oscar & Sergi Devesa.

Chrome / Cromo.



8101.

**8101.**

2 x G9 230V 40W Max.  
(OSRAM HALOPIN)

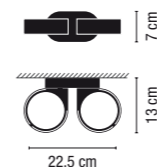

22,5 cm

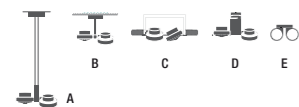

CORNER. Family / Familia  
Pages / Páginas: A-208/210. B-277/278. C-284/286/288.  
D-302/304. E-364/365.

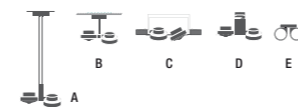

CORNER. Family / Familia  
Pages / Páginas: A-208/210. B-277/278. C-284/286/288.  
D-302/304. E-364/365.



8101-01.



8100-01.



WALL LAMPS  
APLIQUES



2004.  
Lacado negro / black lacquer.



2004.  
Lacado blanco / White lacquer.



2004.  
Gold finish / Acabado oro.



2004.  
Lacado rojo / Red lacquer.



2004.  
Cromo / Chrome.

WALL LAMPS  
APLIQUES





**Mini Funnel**

White lacquer, black lacquer, red lacquer, chrome or gold finish / Lacado blanco, lacado negro, lacado rojo, cromo y acabado oro. Aluminium diffuser / Difusor de aluminio.

2004-03. White lacquer / Lacado blanco. 2004-04. Black lacquer / Lacado negro. 2004-06. Red lacquer / Lacado rojo.



2004-01. Chrome / Cromo. 2004-51. Gold finish / Acabado oro.

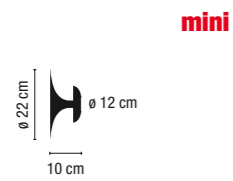

**2004.**  
2 x G9 230V 75W Max.  
(OSRAM HALOPIN).

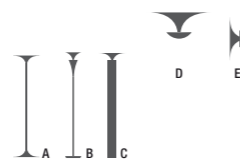

FUNNEL. Family / Familia  
Pages / Páginas: A-32. B-34. C-37. D-218/222. E-370/375.

WALL LAMPS  
APLIQUES



2004-51.



Ø 22 cm

mini



WALL LAMPS  
APLIQUES



2004-49.





**Funnel**  
Design by Ramon Benedito.

White lacquer, black lacquer,  
red lacquer or chrome /  
Lacado blanco, lacado negro,  
lacado rojo o cromo.  
Aluminium diffuser / Difusor de aluminio.

White lacquer / Lacado blanco  
Aluminium diffuser / Difusor de aluminio.

**2010.**  
3 x R7s 80mm. 230V 100W Max.

**2011.**  
GX13 22W Max (T5).

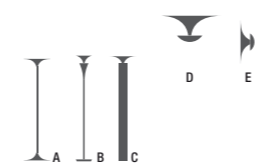
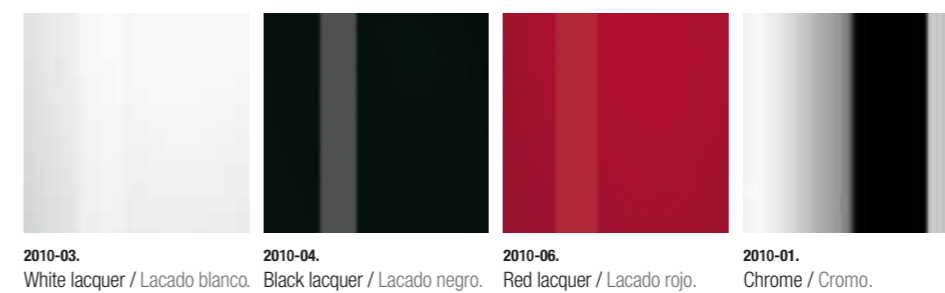

WALL LAMPS  
APLIQUES





Glass on top and bottom / Vidrio en la parte superior e inferior.

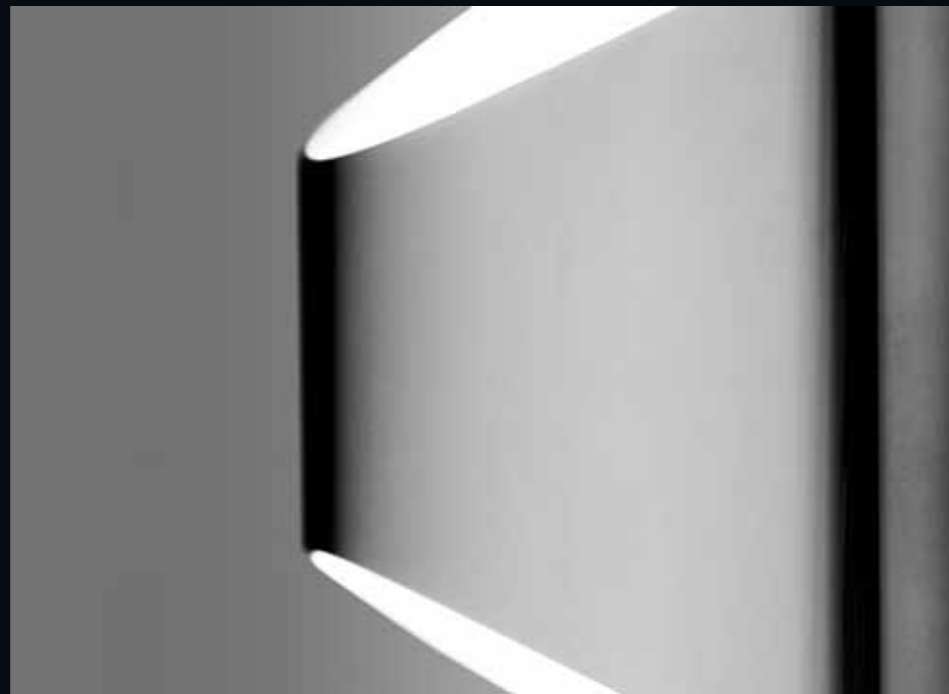

**Pad**  
Design by Proli Diffusion Studio.

Chrome / Cromo.  
Aluminum and borosilicate diffuser / Difusor de borosilicato y aluminio.

**0975.**

R7s 80mm.  
230V 60W Max.



**0976.**

R7s 80mm.  
230V 60W Max.

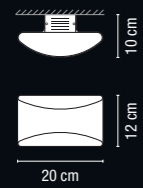

**0977.**

R7s 80mm.  
230V 60W Max.



WALL LAMPS  
APLIQUES

0975.



0976.



0977.





0976.



0977.



0975.

WALL LAMPS  
APLIQUES

30 cm



4351.

® THE ORIGINAL

mini  
16 x 16 cm

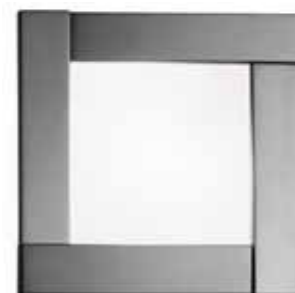

4350.

® THE ORIGINAL

**Tecto**  
Design by Proli Diffusion Studio.

Matt stainless steel, shiny stainless steel, /  
Acero inoxidable mate, acero inoxidable brillo.  
Optical glass diffuser / Difusor de vidrio óptico.

<p><b>4351.</b> R7s 80 mm. 230V 150W Max.</p>	
<p><b>4350.</b> G9 230V 60W Max. (OSRAM HALOPIN). Opal glass diffuser / Difusor de vidrio opal.</p>	<p style="color: red; font-weight: bold;">mini</p>

WALL LAMPS  
APLIQUES



30 x 30 cm  
TECTO, 4351.

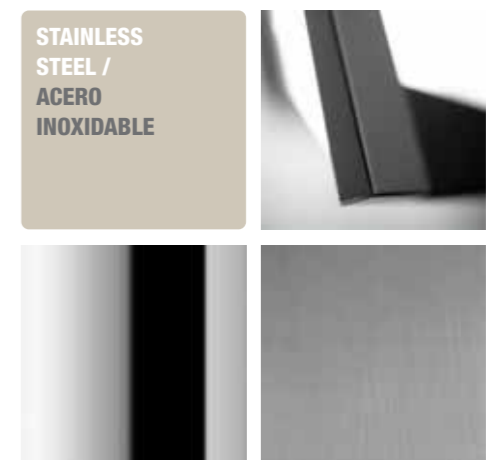

SHINY STAINLESS STEEL / ACERO INOXIDABLE BRILLO      MATT STAINLESS STEEL / ACERO INOXIDABLE MATE

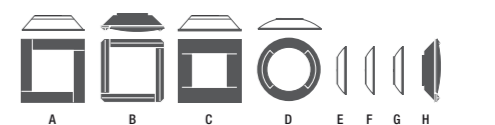

**Tecto**

Design by Prolif Diffusion Studio.

Matt stainless steel, shiny stainless steel /  
Acero inoxidable mate, acero inoxidable brillo  
Optical glass diffuser / Difusor de vidrio óptico.

**4356.**  
R7s 80 mm.  
230V 150W Max.

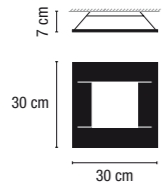

**4355.**  
G9 230V 60W Max.  
(OSRAM HALOPIN).  
Opal glass diffuser /  
Difusor de vidrio opal.

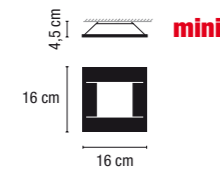

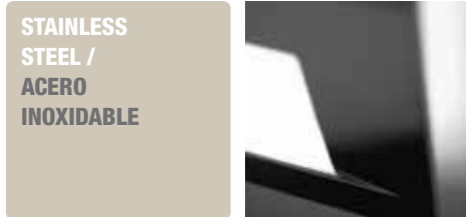

4356.

® THE ORIGINAL



4355.

® THE ORIGINAL

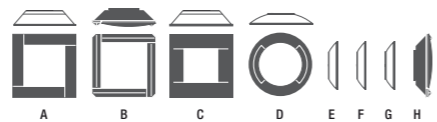

TECTO. Family / Familia  
Pages / Páginas: A-231. B-235. C-237. D-239. E-383. F-384. G-386. H-388.

WALL LAMPS  
APLIQUES



16 x 16 cm

MINI TECTO, 4355.



**Tecto**  
Design by Prolif Diffusion Studio.

Matt stainless steel, shiny stainless steel, /  
Acero inoxidable mate, acero inoxidable brillo.  
Optical glass diffuser / Difusor de vidrio óptico.

<p><b>4366.</b></p> <p>R7s 80 mm. 230V 150W Max.</p>	 <p>6.5 cm</p> <p>ø 33 cm</p>
<p><b>4365.</b></p> <p>G9 230V 60W Max. (OSRAM HALOPIN). Opal glass diffuser / Difusor de vidrio opal.</p>	 <p>4.5 cm</p> <p>mini</p> <p>ø 18 cm</p>

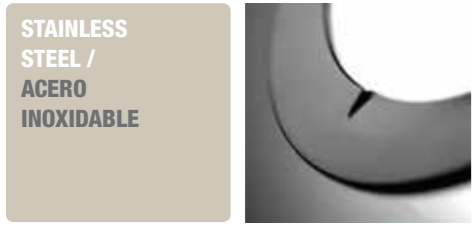

ø 33 cm

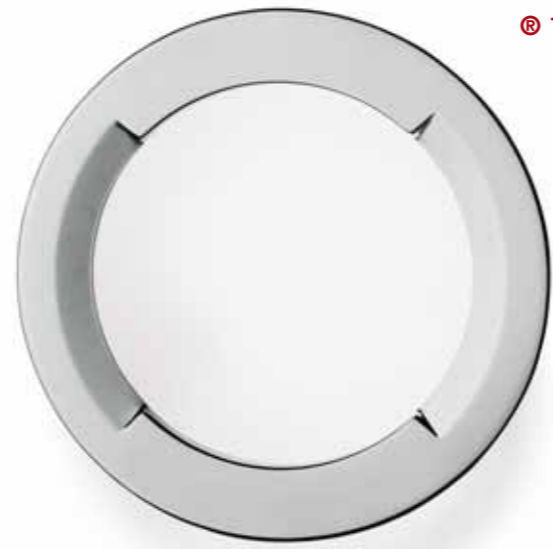

® THE ORIGINAL

4366.

mini

ø 18 cm



® THE ORIGINAL

4365.



TECTO. Family / Familia  
Pages / Páginas: A-231. B-235. C-237. D-239. E-383. F-384. G-386. H-388.

WALL LAMPS  
APLIQUES

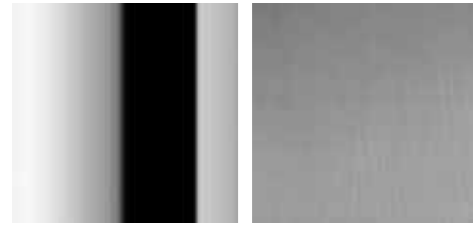

Shiny stainless steel / Acero inoxidable brillo  
Matt stainless steel / Acero inoxidable mate.

**Tecto**  
Design by Proli Diffusion Studio.

Shiny stainless steel or matt stainless steel / Acero inoxidable brillo o acero inoxidable mate.  
Opal glass diffuser / Difusor de vidrio opal.

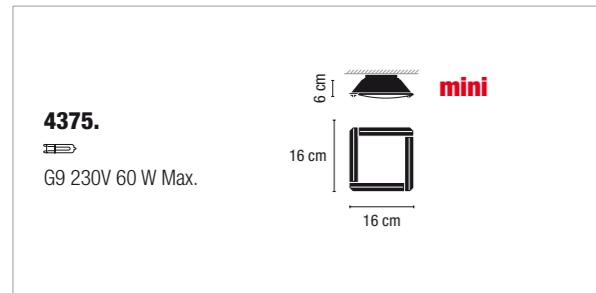

STAINLESS  
STEEL /  
ACERO  
INOXIDABLE

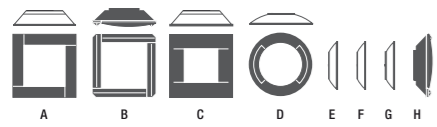

TECTO. Family / Familia  
Pages / Páginas: A-231. B-235. C-237. D-239. E-383. F-384. G-386. H-388.

WALL LAMPS  
APLIQUES



4375.  
mini

mini

16 x 16 cm



4375-01.

® THE ORIGINAL



42 cm

® THE ORIGINAL

**Quadra Ice**  
Design by Proli Diffusion Studio.

Optical glass diffuser / Difusor de vidrio óptico.

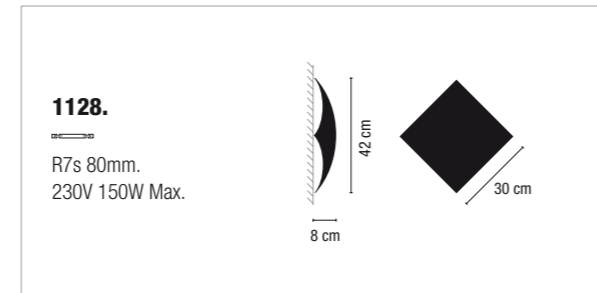

**1128.**  
R7s 80mm.  
230V 150W Max.

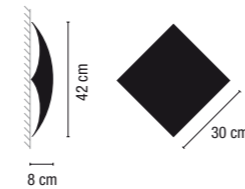

**Mini Quadra**  
Design by Proli Diffusion Studio.

Optical glass diffuser / Difusor de vidrio óptico.



mini

16,8 cm

® THE ORIGINAL



**8400.**  
G9 230V 60 W Max.

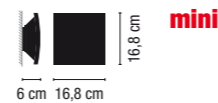

**Surface / Superficie**

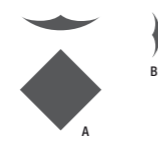

QUADRA ICE. Family / Familia  
Pages / Páginas : A-253. B-390.

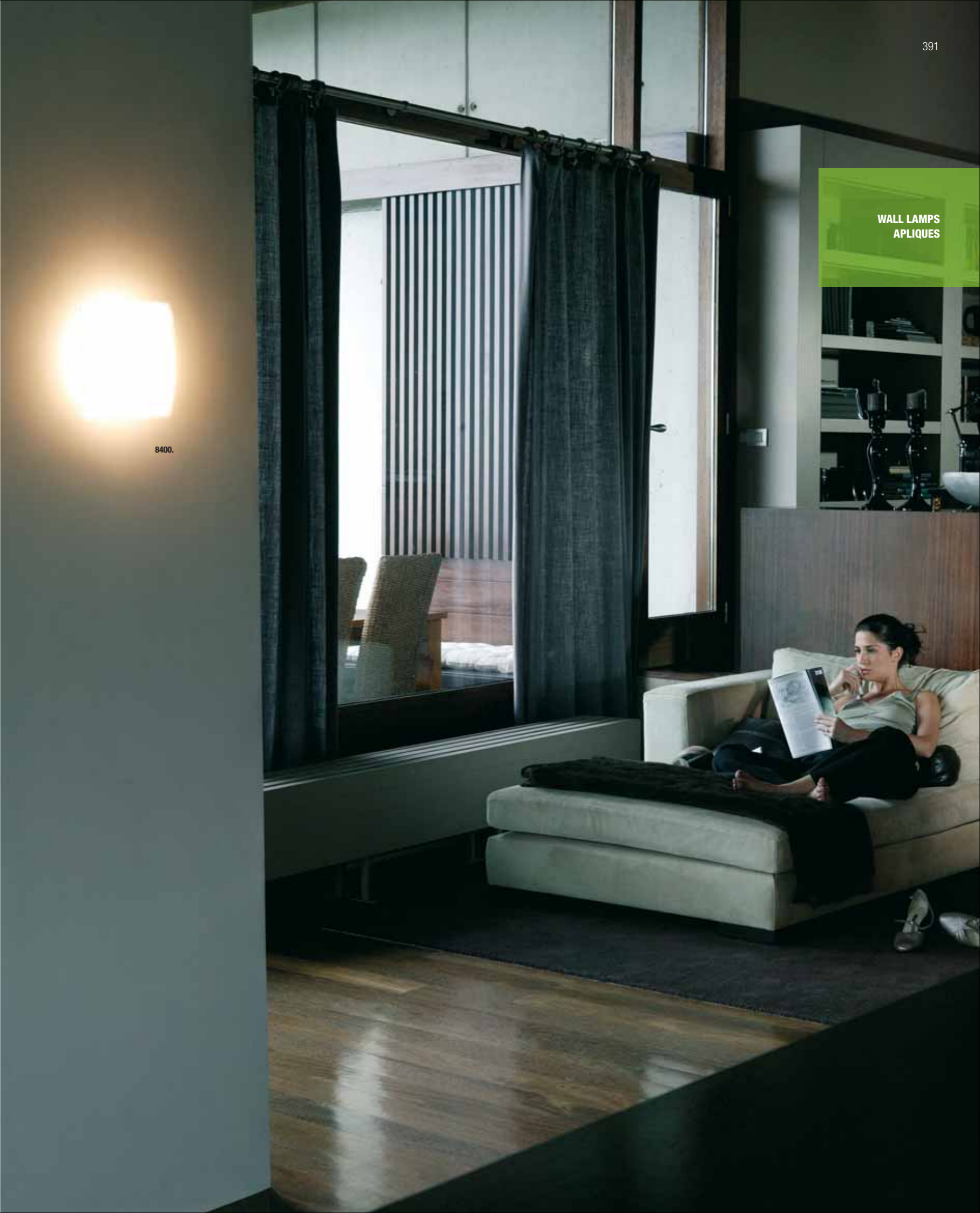

WALL LAMPS  
APLIQUES

8400.



4255.

45 x 45 cm

**Watch**

Design by Proli Diffusion Studio.

Chrome / Cromo

Opal triplex blown-glass diffuser / Difusor de vidrio soplado opal triplex.

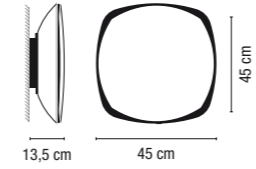
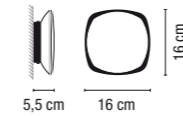
**4255.**R7s 117mm.  
230V 200W Max.**4250.**G9 230V 60W Max.  
(OSRAM HALOPIN)**mini****4251.**

GX53 9W.

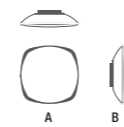
WATCH. Family / Familia  
Pages / Páginas: A-249. B-393.

mini

16 x 16 cm



8604.

mini

Ø 17,5 cm



8606.

® THE ORIGINAL



8600.



8608.

® THE ORIGINAL

® THE ORIGINAL

**Mini Sandwich**

Design by Proli Diffusion Studio.

Chrome, matt nickel / Cromo, Níquel mate.  
Opal glass diffuser / Difusor de vidrio opal.

**8600 / 8604 / 8608.**

G9 230V 60W Max.  
OSRAM HALOPIN).

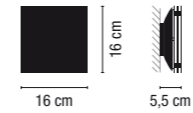

**8606.**

G9 230V 60W Max.  
OSRAM HALOPIN).

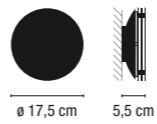

**Surface / Superficie**



**NEW CHROME FINISH /  
NUEVO ACABADO CROMO**

Chrome / Cromo.

Matt nickel / Níquel mate.

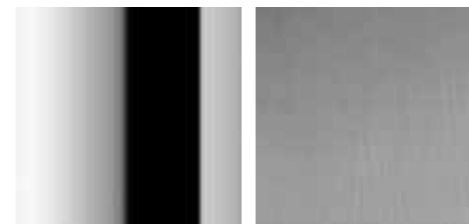

WALL LAMPS  
APLIQUES

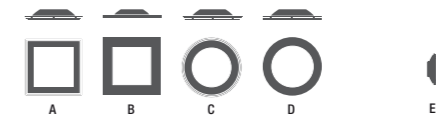

SANDWICH. Family / Familia  
Pages / Páginas: A-243. B-243. C-245. D-245. E-395/397.

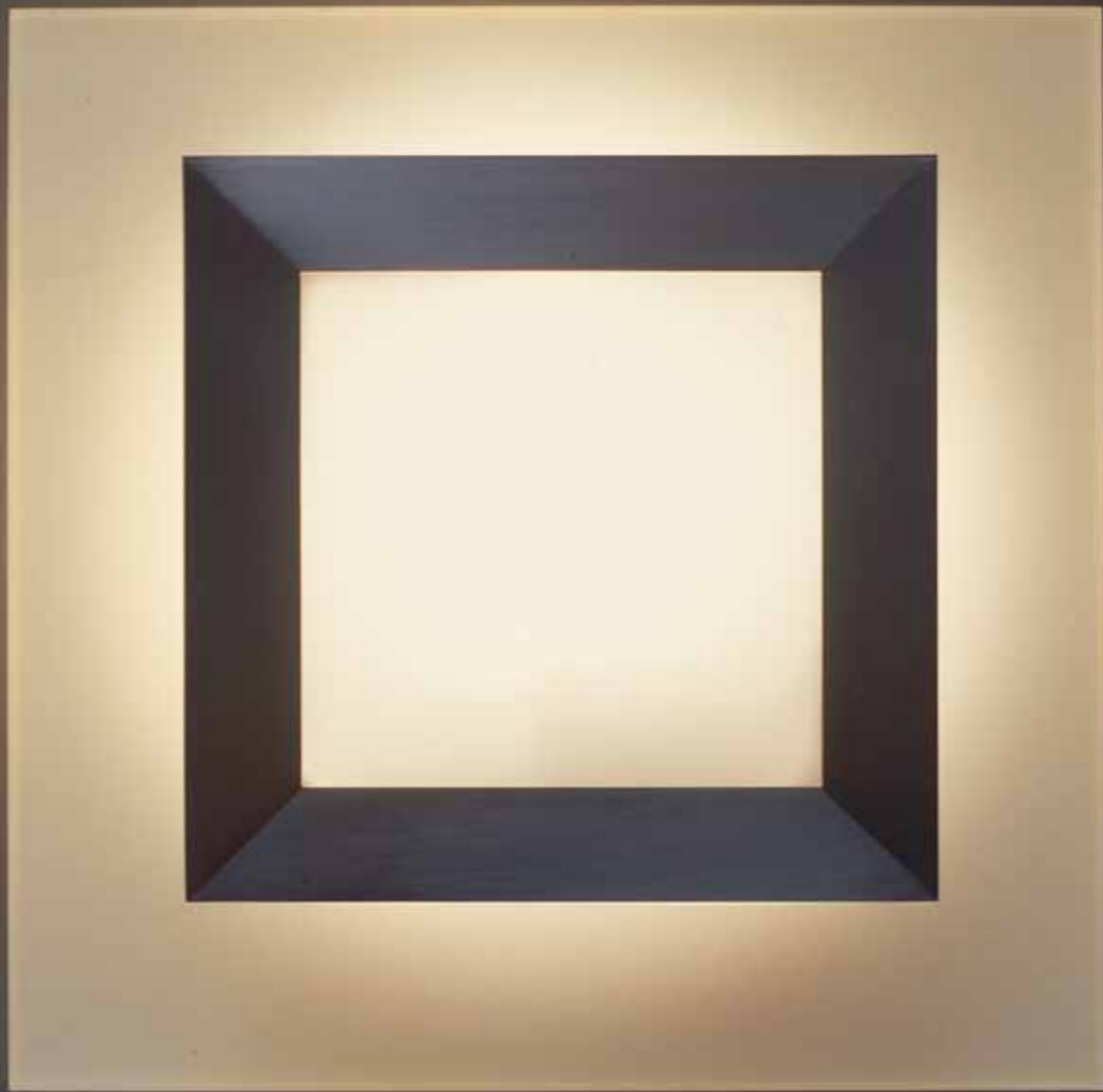

8614.

**25 x 25 cm**

Mini Sandwich Glass

WALL LAMPS  
APLIQUES

**Mini Sandwich Glass**

Design by Prolí Diffusion Studio.

Chrome, matt nickel / Cromo, Níquel mate.  
Glass diffuser / Difusor de vidrio.

**8614.**

G9 230V 60W Max.  
(OSRAM HALOPIN).

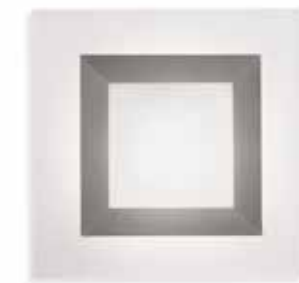
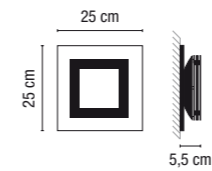

® THE ORIGINAL



OPTICAL GLASS / VIDRIO ÓPTICO.



**25 x 25 cm**

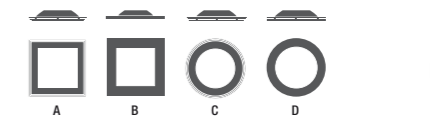

SANDWICH. Family / Familia  
Pages / Páginas: A-243. B-243. C-245. D-245. E-395/397.

WALL LAMPS  
APLIQUES

Ø 17,5 cm



8720-30.

® THE ORIGINAL

16 cm



8772-30.

® THE ORIGINAL

Signal

Product design by Proli Difussion Studio.  
Signage graphic design by Joan Buxadé.

Stainless steel / Acero inoxidable.  
Opal glass diffuser / Difusor de vidrio opal.

**8700 / 8701 / 8702**  
**8708 / 8720 / 8721.**  
GX53 9W.

**8751 / 8752 / 8753**  
**8759 / 8771 / 8772.**  
GX53 9W.



© THE ORIGINAL

1276.

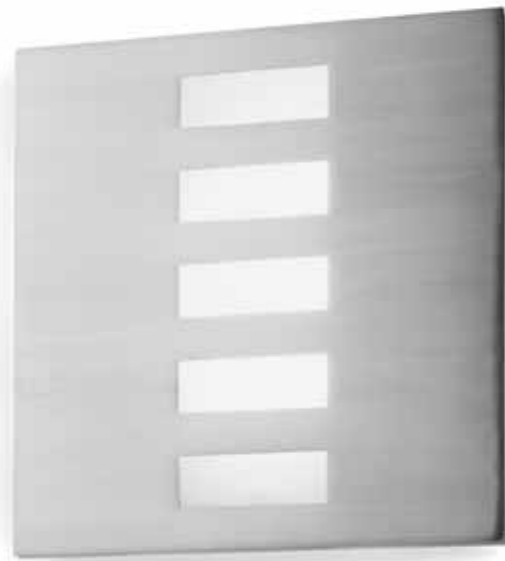

30 x 30 cm

**Soho**  
Design by Proli Diffusion Studio.

Matt nickel / Niquel mate.  
Optical glass diffuser / Difusor de vidrio óptico.

<p><b>1276.</b> 2G10 36W Max.</p>	
<p><b>1281.</b> 2G10 36W Max.</p>	
<p><b>1290.</b> R7s 80mm. 230V 150W Max.</p>	
<p><b>1291.</b> R7s 80mm. 230V 150W Max.</p>	



HALOGENE OR COMPACT FLUORESCENT /  
HALÓGENA O FLUORESCENTE COMPACTA

SOHO

30 x 30 cm

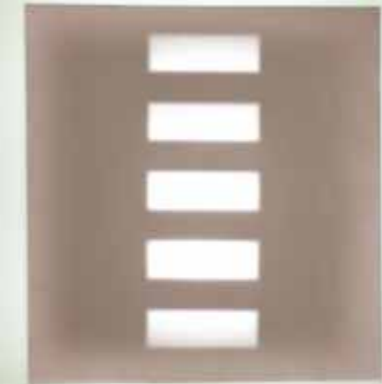

WALL LAMPS  
APLIQUES

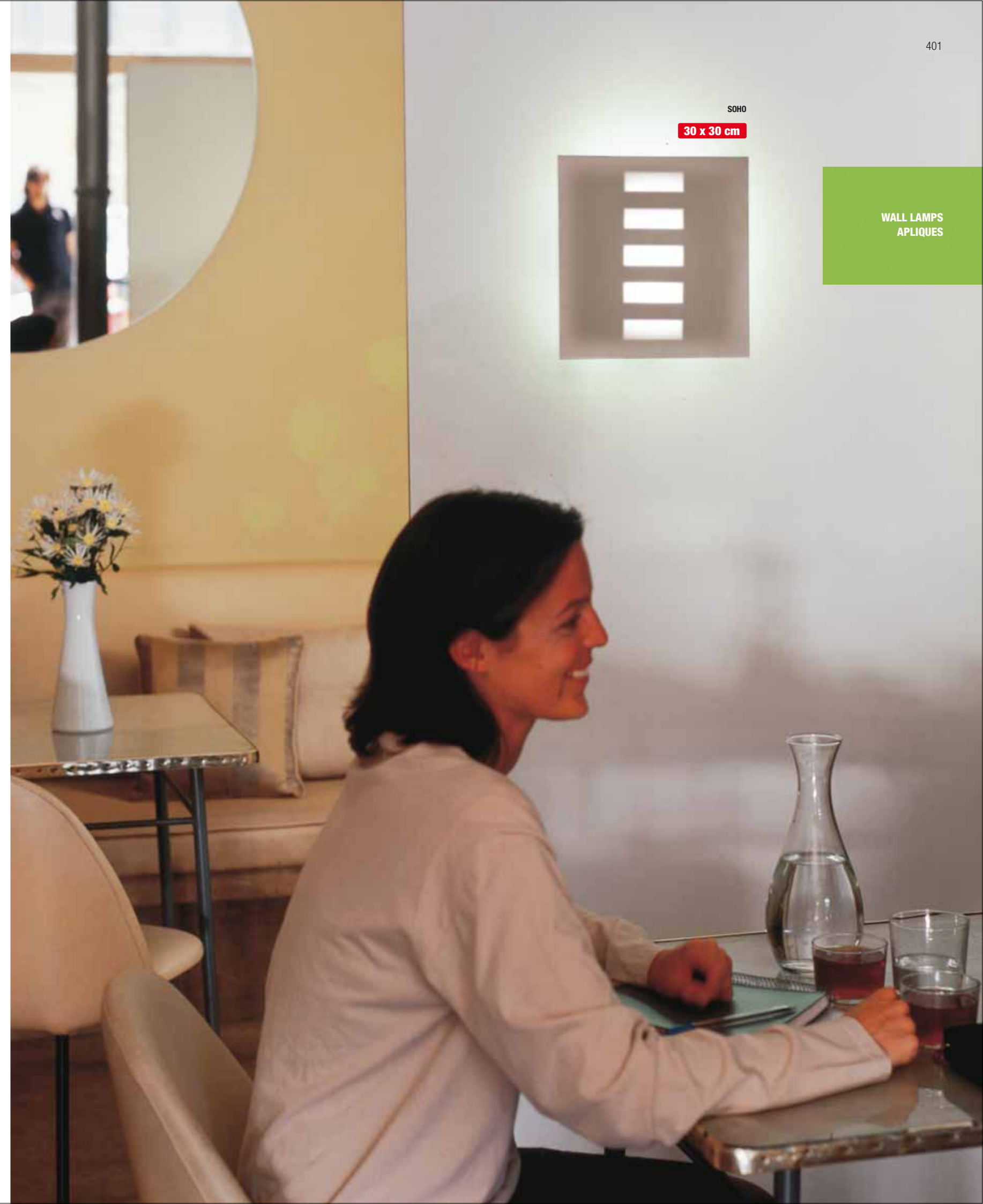



**mini**  
SIZE / TAMAÑO  
15,5 x 15,5 cm

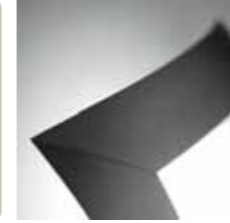

WALL LAMPS  
APLIQUES

**Mini Top**  
Design by Prolif Diffusion Studio.

Matt nickel / Níquel mate.  
Optical glass diffuser / Difusor de vidrio óptico.

**8500.**  
  
G9 230V 60W Max.  
OSRAM HALOPIN).

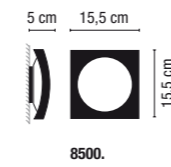

**8502.**  
  
G9 230V 60W Max.  
OSRAM HALOPIN).

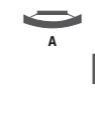
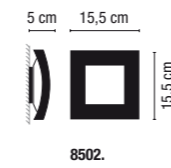

**Scotch**

Design by Oscar and Sergi Devesa.

Chrome / Cromo.  
White glass diffuser /  
Difusor de vidrio blanco.

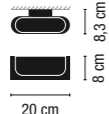
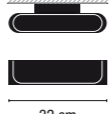
<p><b>0950.</b></p>  <p>2 x G9 230V 60 W Max. (OSRAM HALOPIN)</p>	<p><b>0952.</b></p>  <p>2G11 18W Max.</p>
--	--

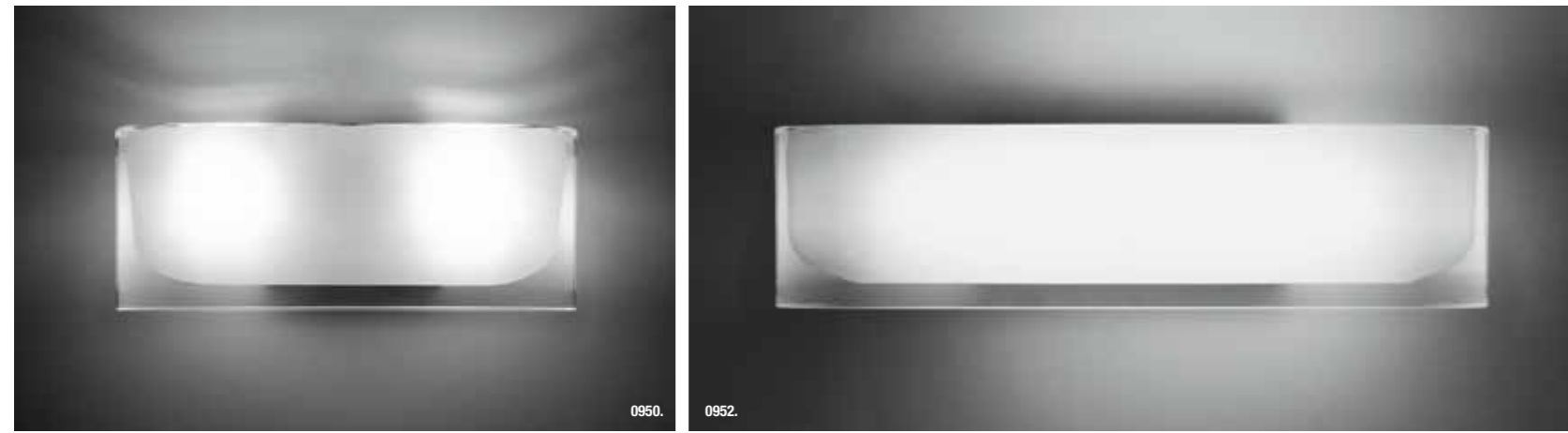

WITHOUT TRANSFORMER / SIN TRANSFORMADOR

NEW SIZE / NUEVO TAMAÑO

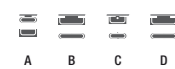

WALL LAMPS  
APLIQUES



**Scotch**

Design by Oscar and Sergi Devesa.

Chrome / Cromo.  
White glass diffuser /  
Difusor de vidrio blanco.

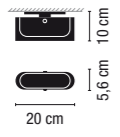
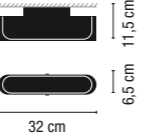
<p><b>0951.</b></p>  <p>2 x G9 230V 60 W Max. (OSRAM HALOPIN)</p>	<p><b>0953.</b></p>  <p>2G11 18W Max.</p>
--	--

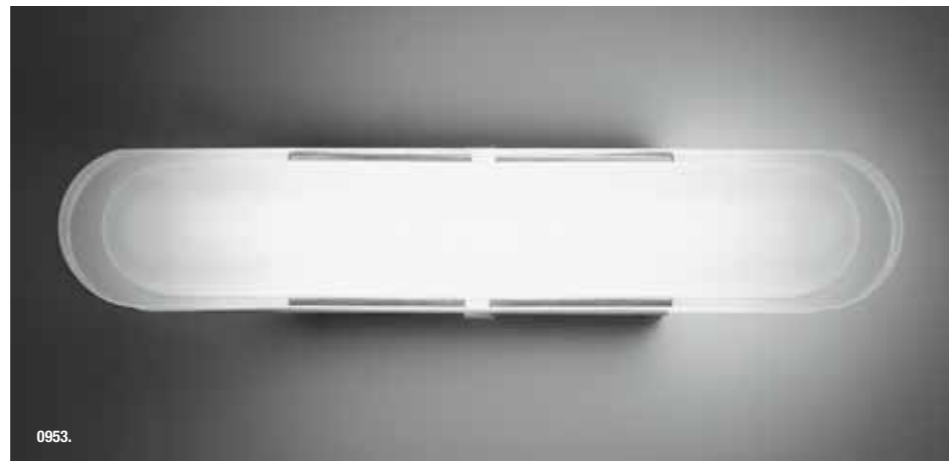
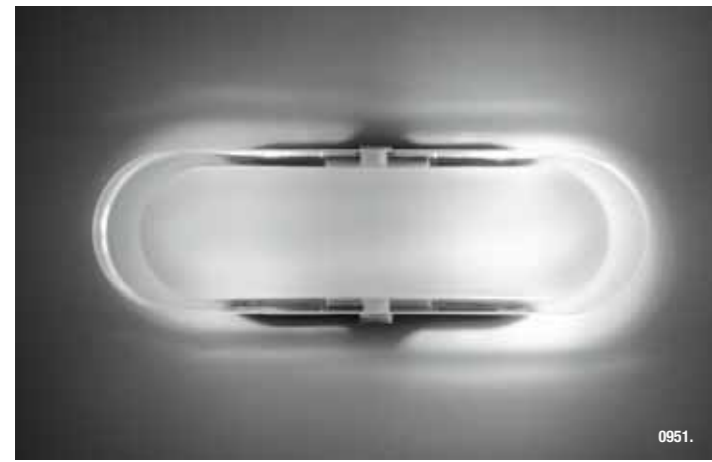

WITHOUT TRANSFORMER / SIN TRANSFORMADOR

NEW SIZE / NUEVO TAMAÑO

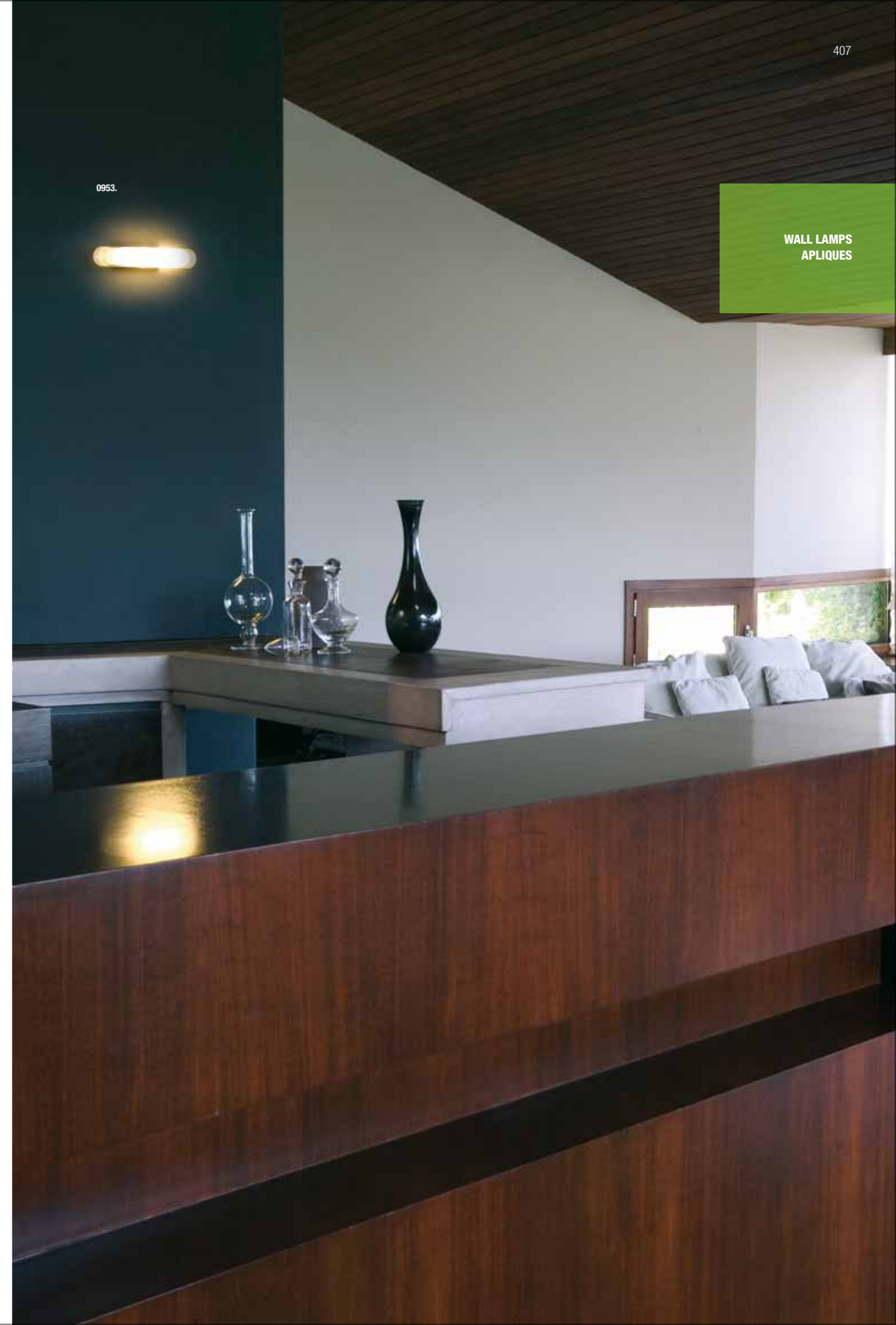
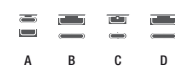

WALL LAMPS  
APLIQUES

Chrome / Cromo. Matt nickel / Níquel mate.

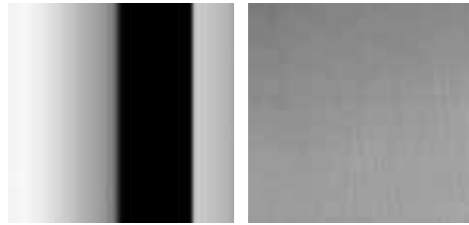

**Zero**  
Design by Oscar & Sergi Devesa.

Chrome, matt nickel / Cromo, Níquel mate.

**5245.**

R7s 80mm.  
230V 60W Max.  
Borosilicate and aluminium  
diffuser / Difusor de borosilicato  
y aluminio.

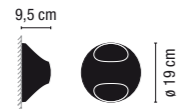

**5246.**

GX53 9W.  
Aluminium diffuser /  
Difusor de aluminio.



5245.

Ø 19 cm



5246.

Ø 19 cm



WALL LAMPS  
APLIQUES

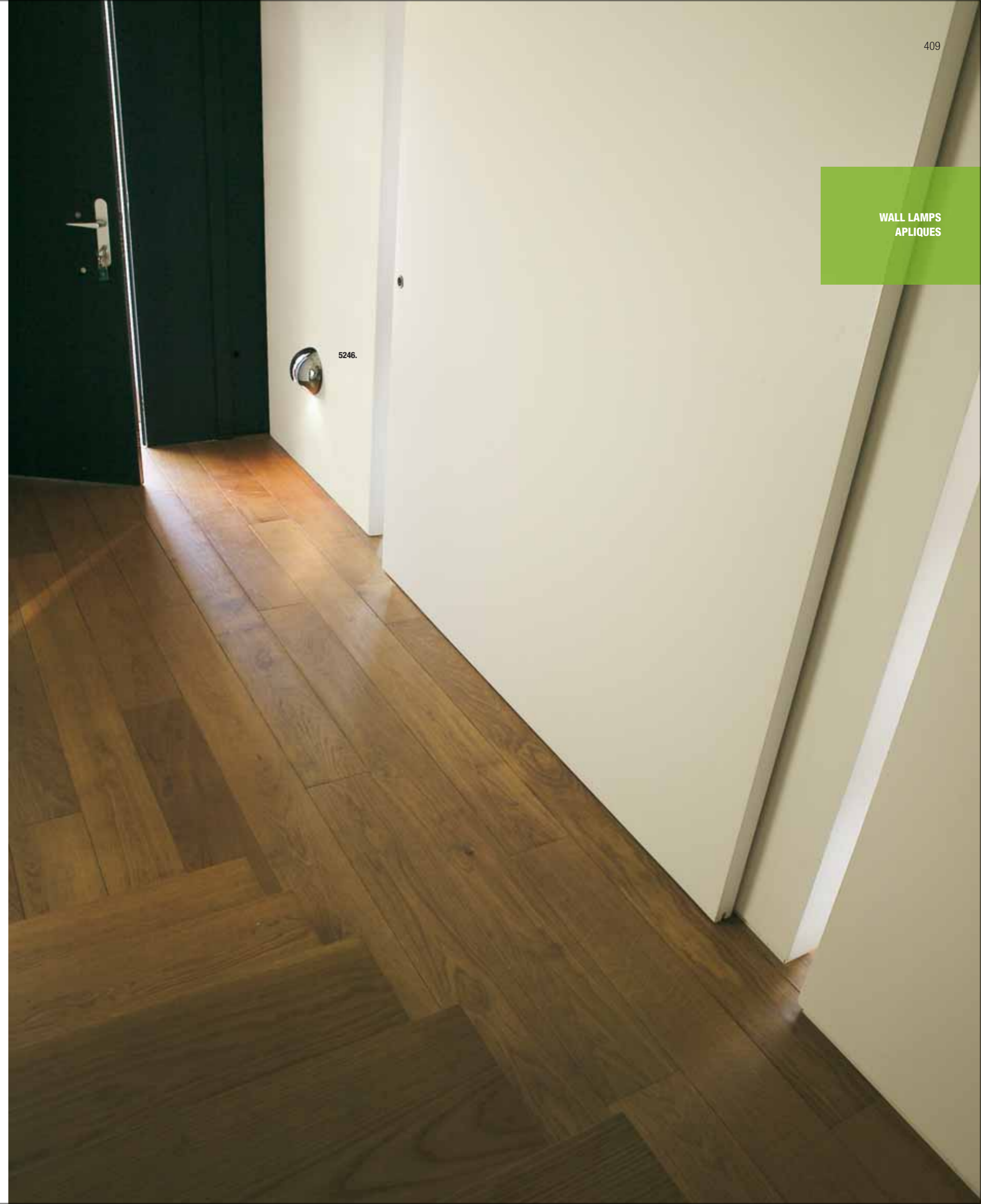



5257.

## Te

Design by Lievore, Alther, Molina.

Metallic silver / Lacado plata.  
Optical glass diffuser / Difusor de vidrio óptico.

### 5257.

R7s 80mm.  
230V 150W Max.

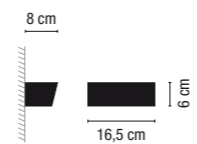

### 5258.

R7s 117mm.  
230V 200W Max.

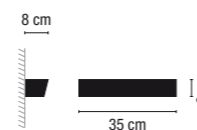

## HALOGEN / HALÓGENO

Metallic silver / Lacado plata.  
Methacrylate diffuser / Difusor de metacrilato.

### 5263.

2G11 24W Max.

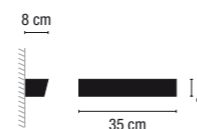

## COMPACT FLUORESCENT / FLUORESCENTE COMPACTA



TE. Family / Familia  
Pages / Páginas: A-46. B-425. C-410. D-410.

5258.

**Ona**  
Design by Jordi Vilardell.

Chrome / Cromo.  
Aluminium diffuser / Difusor de aluminio.



1250.

**1250.**

R7s 80mm.  
230V 150W Max.

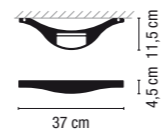
**1251.**

R7s 117mm.  
230V 200W Max.

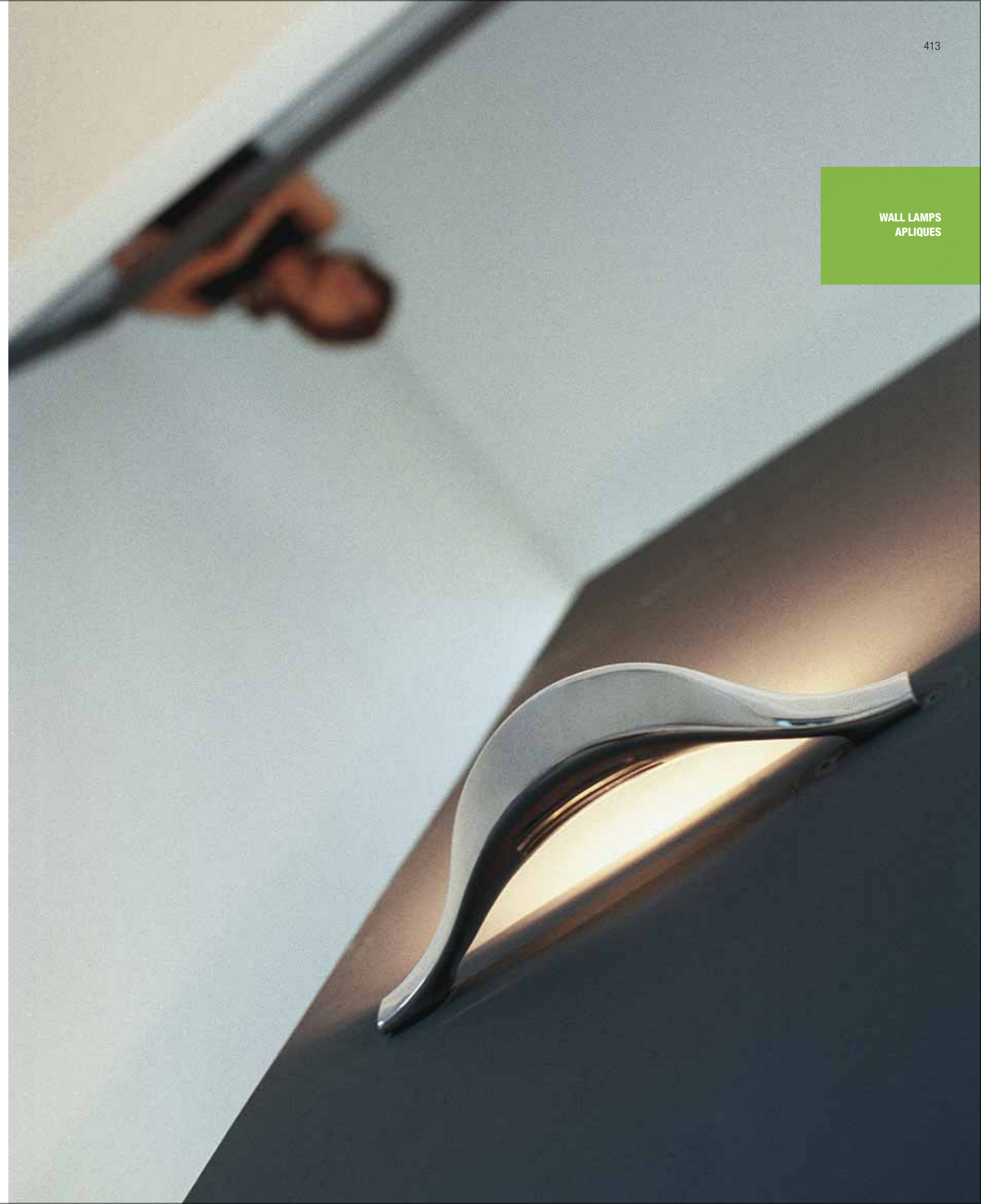
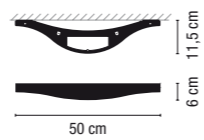



1320.

**Sinuosa**

Design by Proli Diffusion Studio.

Matt nickel / Niquel mate.  
Methacrylate diffuser / Difusor de metacrilato.

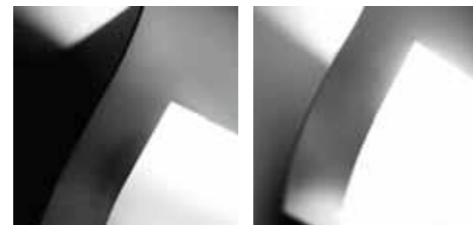

**1320.**

R7s 117mm.  
230V 100W Max.

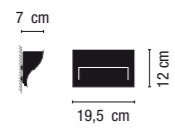

**1325.**

2G11 36W Max.

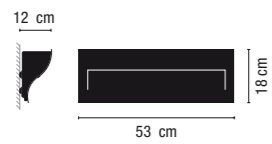

WALL LAMPS  
APLIQUES

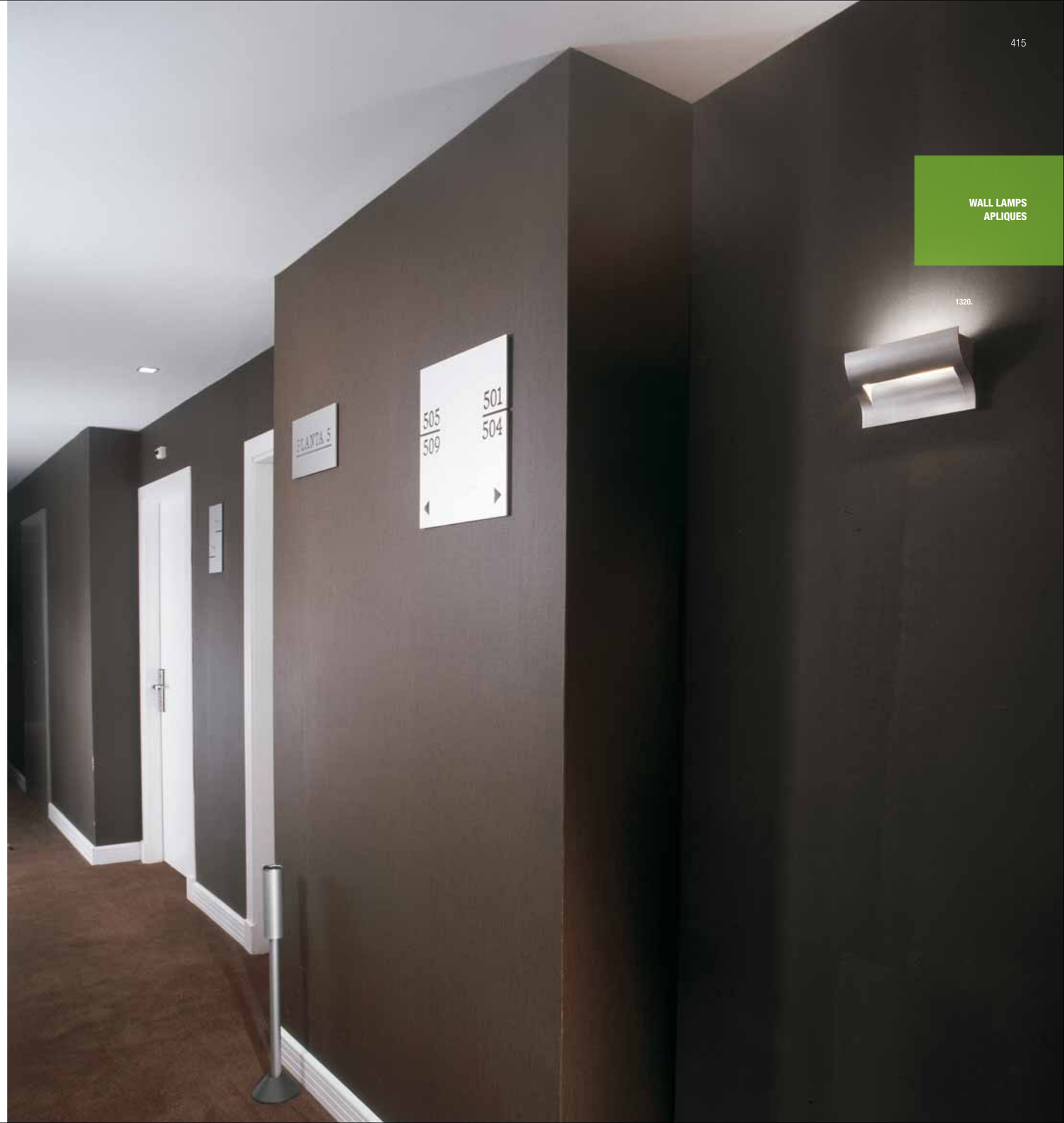

1320.



8633.

Ø 14 cm



8631.

Ø 10 cm



8632.

11 x 11 cm



8630.

9 x 9 cm

**Basik**  
Design by Proli Diffusion Studio.

Chrome / Cromo.  
Glass and borosilicate diffuser / Difusor de vidrio y borosilicato.

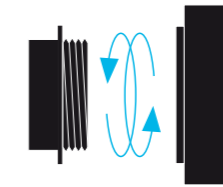

**8631.**

G9 230V 40W Max.  
(OSRAM HALOPIN).

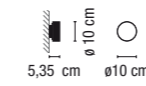

**8633.**

G9 230V 40W Max.  
(OSRAM HALOPIN).

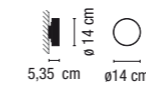

**8630.**

G9 230V 40W Max.  
(OSRAM HALOPIN).

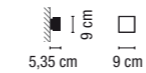

**8632.**

G9 230V 40W Max.  
(OSRAM HALOPIN).

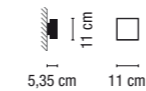

WALL LAMPS  
APLIQUES





5240.

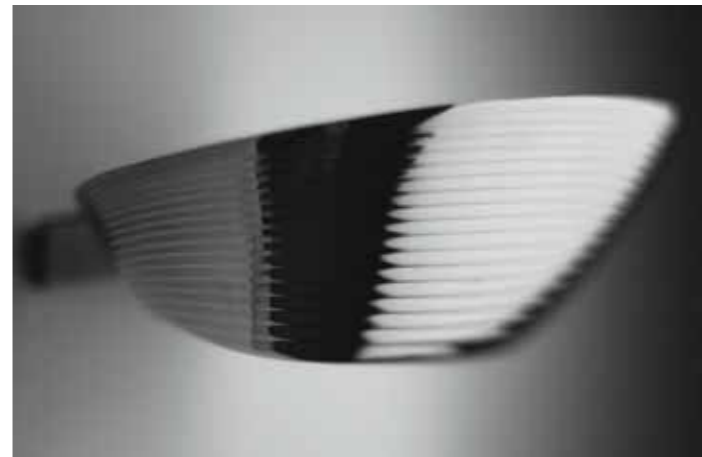

**Shell**

Design by Jordi Vilardell.

**5240.**

Chrome, matt nickel / Cromo, Niquel mate.  
Aluminium diffuser / Difusor de aluminio.  
R7s 117mm. 230V 200W Max.

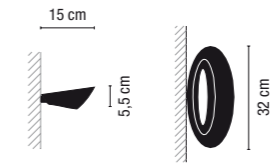

WALL LAMPS  
APLIQUES

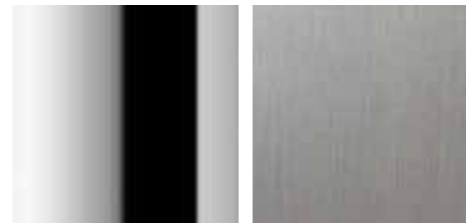

Chrome / Cromo.

Matt nickel / Niquel mate.

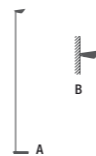

SHELL. Family / Familia  
Pages / Páginas: A-60. B-419.

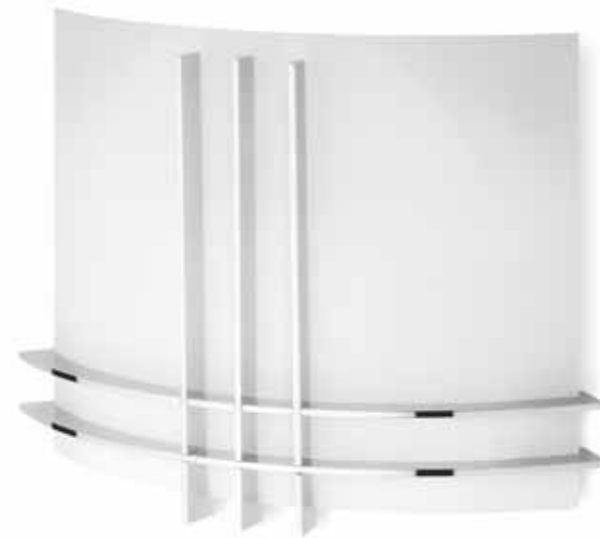

1275.

**Cross**  
Design by Proli Difussion Studio.

**1275.**  
Chrome, matt nickel / Cromo, níquel mate.  
Optical glass diffuser / Difusor de vidrio óptico.  
R7s 80mm. 230V 150W Max.

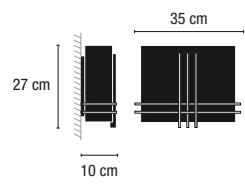

WALL LAMPS  
APLIQUES

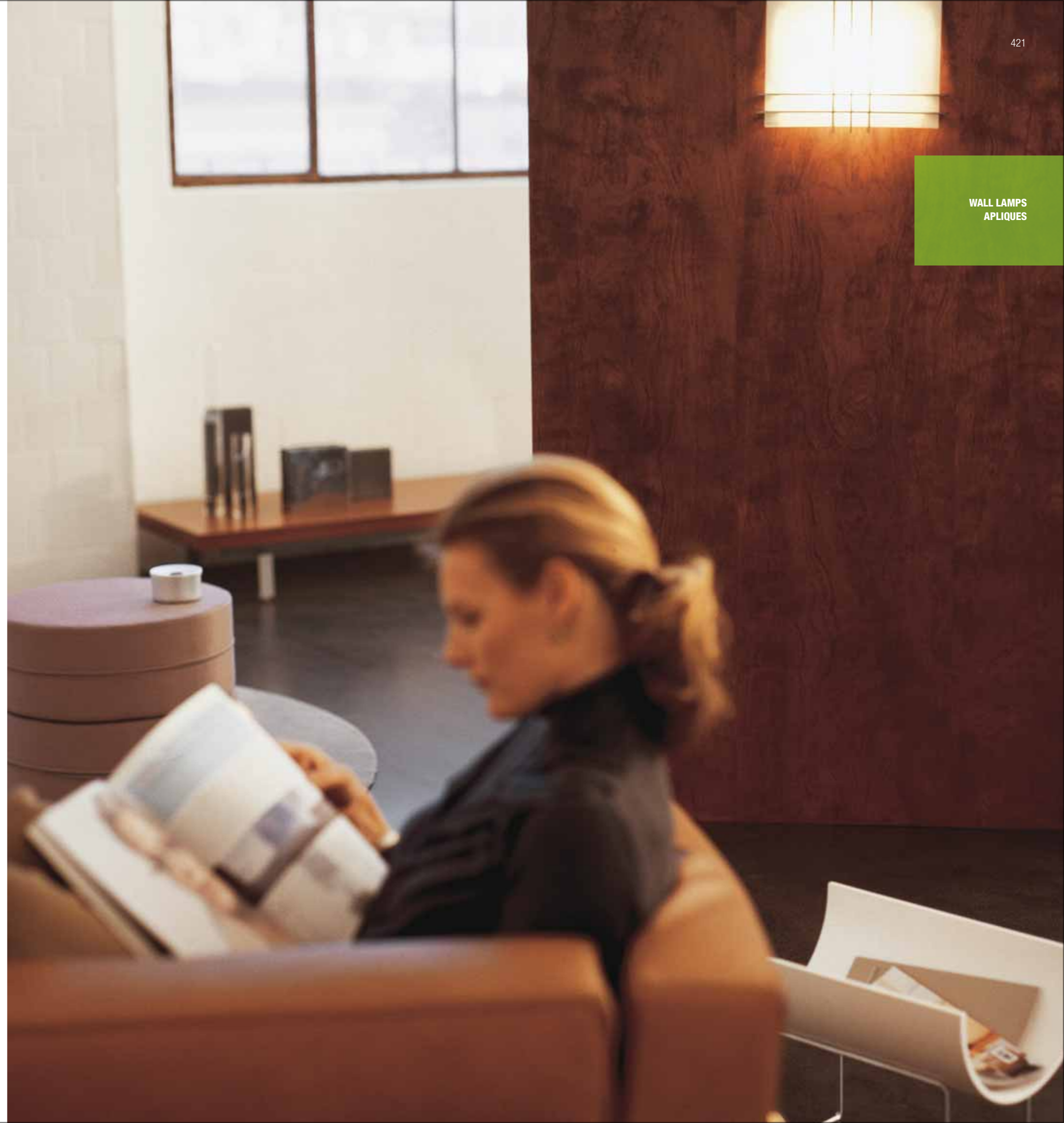

**Tulip**  
Design by Lievore, Altherr, Molina.

**0361.**  
Chrome / Cromo.  
Opal triplex blown-glass diffuser /  
Difusor de vidrio soplado opal triplex.  
E14 Esférica Mate 60W Max.

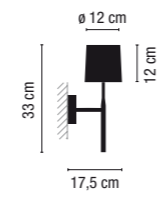

0361.

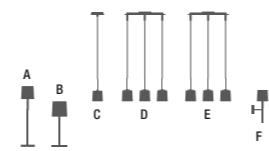

TULIP. Family / Familia  
Pages / Páginas: A-106. B-106. C-166. D-166. E-166. F-422.

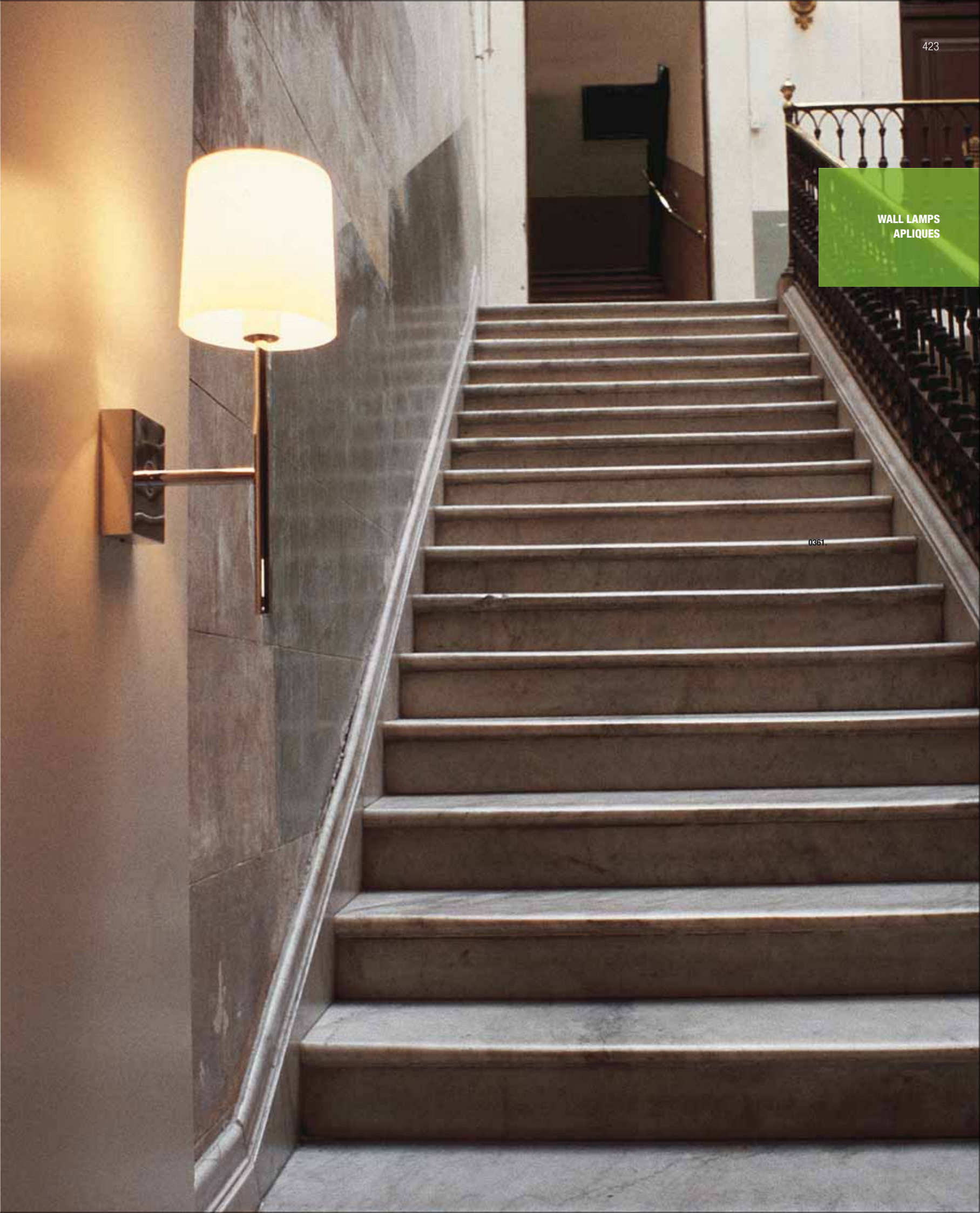

WALL LAMPS  
APLIQUES

0361

5262.



5262.



**Te**  
Design by Lievore, Alther, Molina.

**5262.**  
Metallic silver / Lacado plata.  
Halógena Tubular E14 230V 100W Max.  
G9 230V 60W Max. (OSRAM HALOPIN).

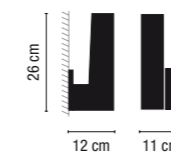

**HALOGEN / HALÓGENO**

The tubular bulb lights upwards  
and the G9 downwards / La bombilla tubular de aluminio  
hacia arriba y la bombilla G9 hacia abajo.



TE. Family / Familia  
Pages / Páginas: A-46. B-425. C-410. D-410.

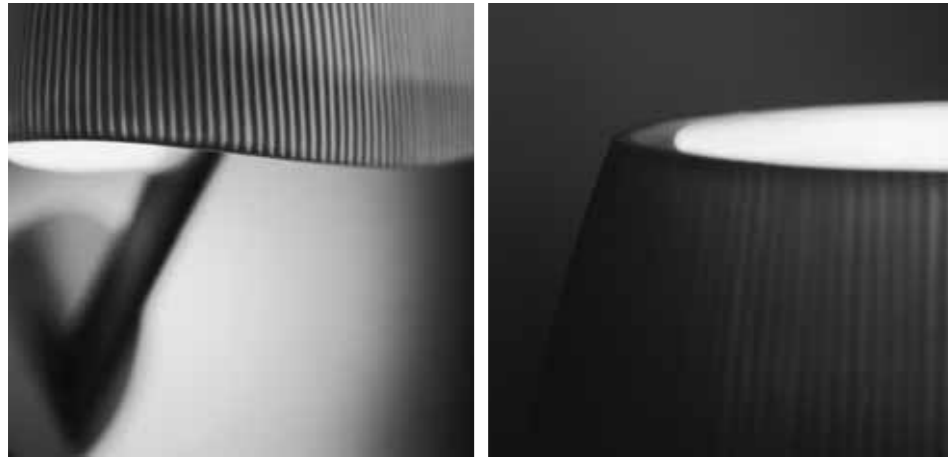

Porcelain diffuser. Glass on the top / Difusor de porcelana. Vidrio en la parte superior

mini

18 cm



5135.

**Mini Aina**  
Design by Jordi Vilardell.

**5135.**  
Matt nickel / Niquel mate.  
Porcelain diffuser / Difusor de porcelana.  
2 x G9 230V 75W Max. (OSRAM HALOPIN).  
⚡

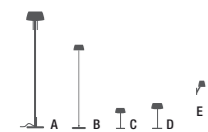

Aina. Family / Familia  
Pages / Páginas: A-38. B-40. C-112. D-112. E-426.

WALL LAMPS  
APLIQUES

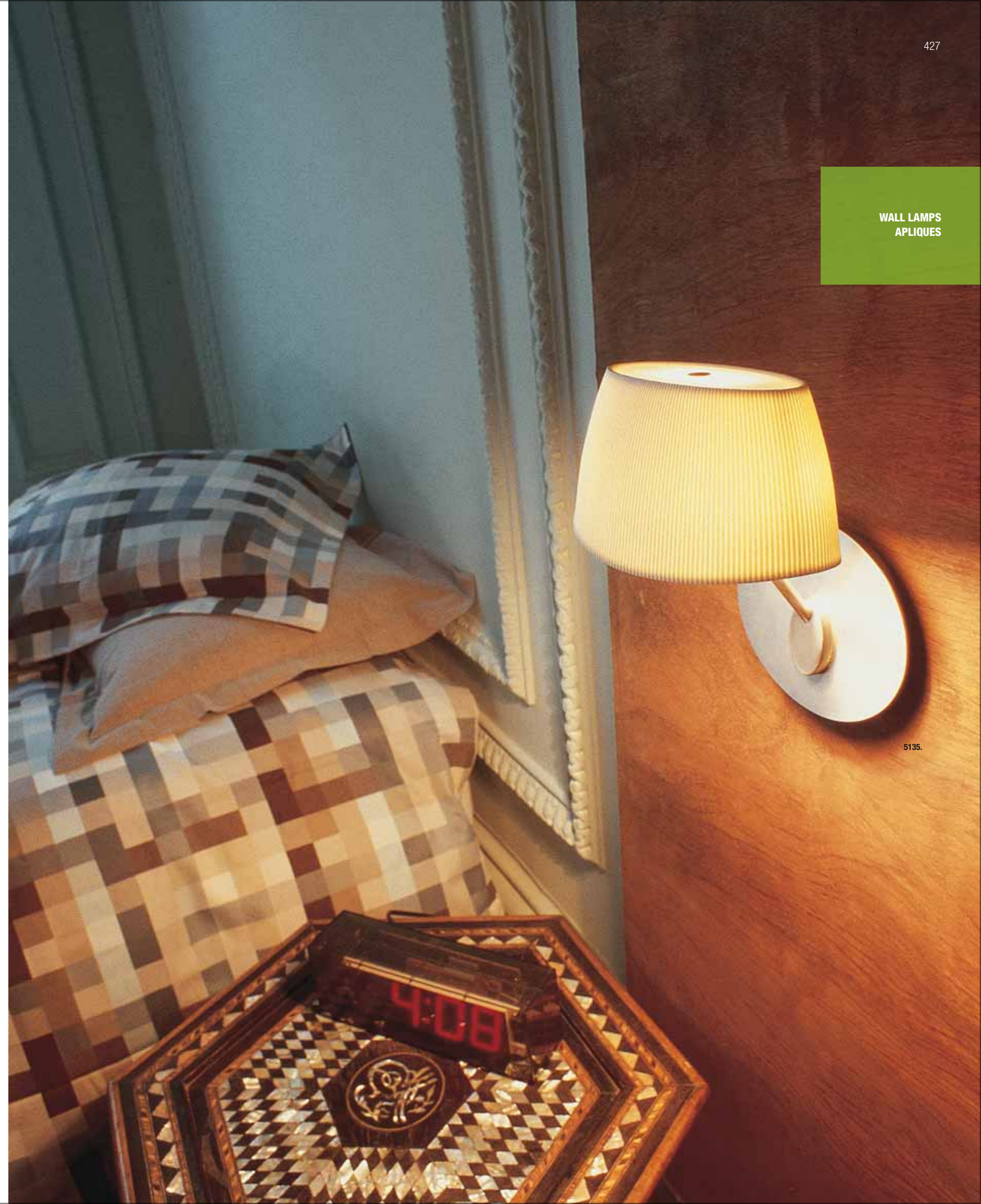

5135.



**8520.**  
Chrome / Cromo.

**Tatiana**  
Design by Estudi Blanc.

**8520.**  
Chrome, silver lacquer / Cromo, lacado plata.  
Opal triplex blown-glass diffuser /  
Difusor de vidrio soplado opal triplex.  
E14 Esférica Mate 60W Max.

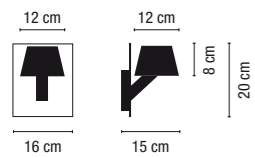

WALL LAMPS  
APLIQUES

8520.

**Mini Lollipop**  
Design by Hopf & Wortman, büro für form.

**0686.**  
White lacquer, black lacquer / Lacado blanco, lacado negro.  
GX53 9W.

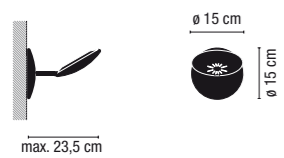

The wall fitting can rotate both at the base and the diffuser, thus allowing any possible lighting angle. /  
La articulación de la pared puede rotar. La cabeza también es giratoria, por lo que cualquier ángulo de iluminación del aplique es posible.



0686-03.



**0686-03.**  
White lacquer /  
Lacado blanco.



**0686-04.**  
Black lacquer /  
Lacado negro.



**mini**  
— **ø 15 cm** —



0686.

WALL LAMPS  
APLIQUES

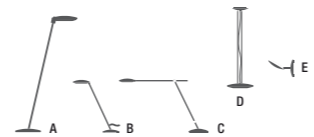

LOLLIPOP. Family / Familia  
Pages / Páginas: A-42. B-120. C-120. D-198. E-430.

**Slim**

Design by Jordi Vilardell.

**0905.**

White lacquer, black lacquer /  
Lacado blanco, lacado negro.  
Borosilicate diffuser / Difusor de borosilicato.  
GY 6,3 (Osram ministar axial) 12V 20W Max.  
G4 12V 20W Max (Osram Halostar standard).

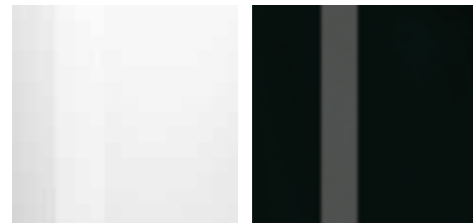
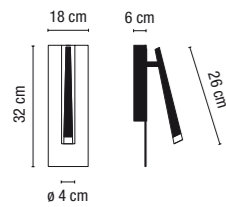

White lacquer / Lacado blanco. Black lacquer / Lacado negro.

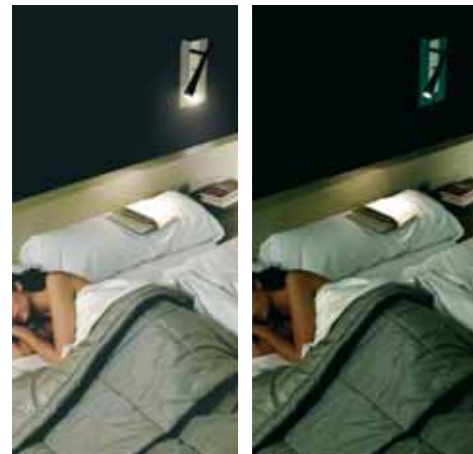

0905.

WALL LAMPS  
APLIQUES

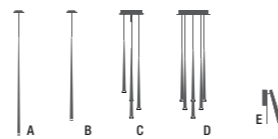

SLIM. Family / Familia  
Pages / Páginas: A-144. B-144. C-148. D-150. E-432.



**Diva**

**0670.**  
Silver lacquer, chrome /  
Lacado plata, cromo.  
E27 60W Max.

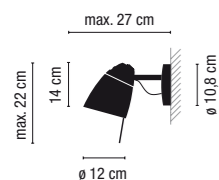

Silver lacquer / Lacado plata  
0670-30.



Chrome / Cromo  
0670-01.

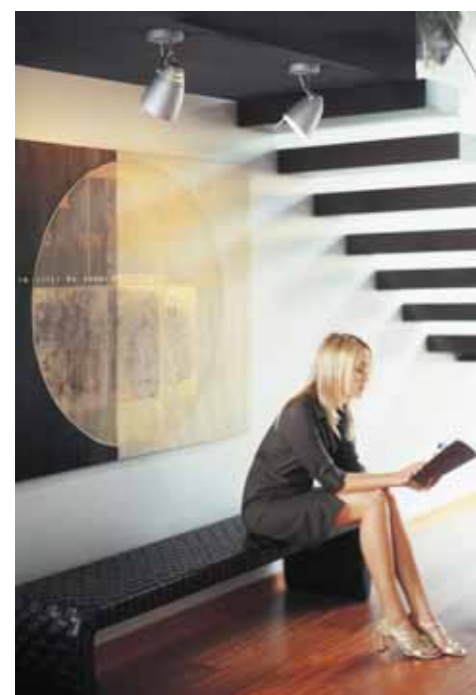

Switch on top of the diffuser / Interruptor en la parte superior.

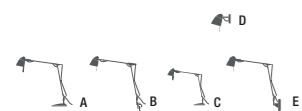

DIVA. Family / Familia  
Pages / Páginas: A-104. B-104. C-104. D-434. E-436.

**WALL LAMPS  
APLIQUES**

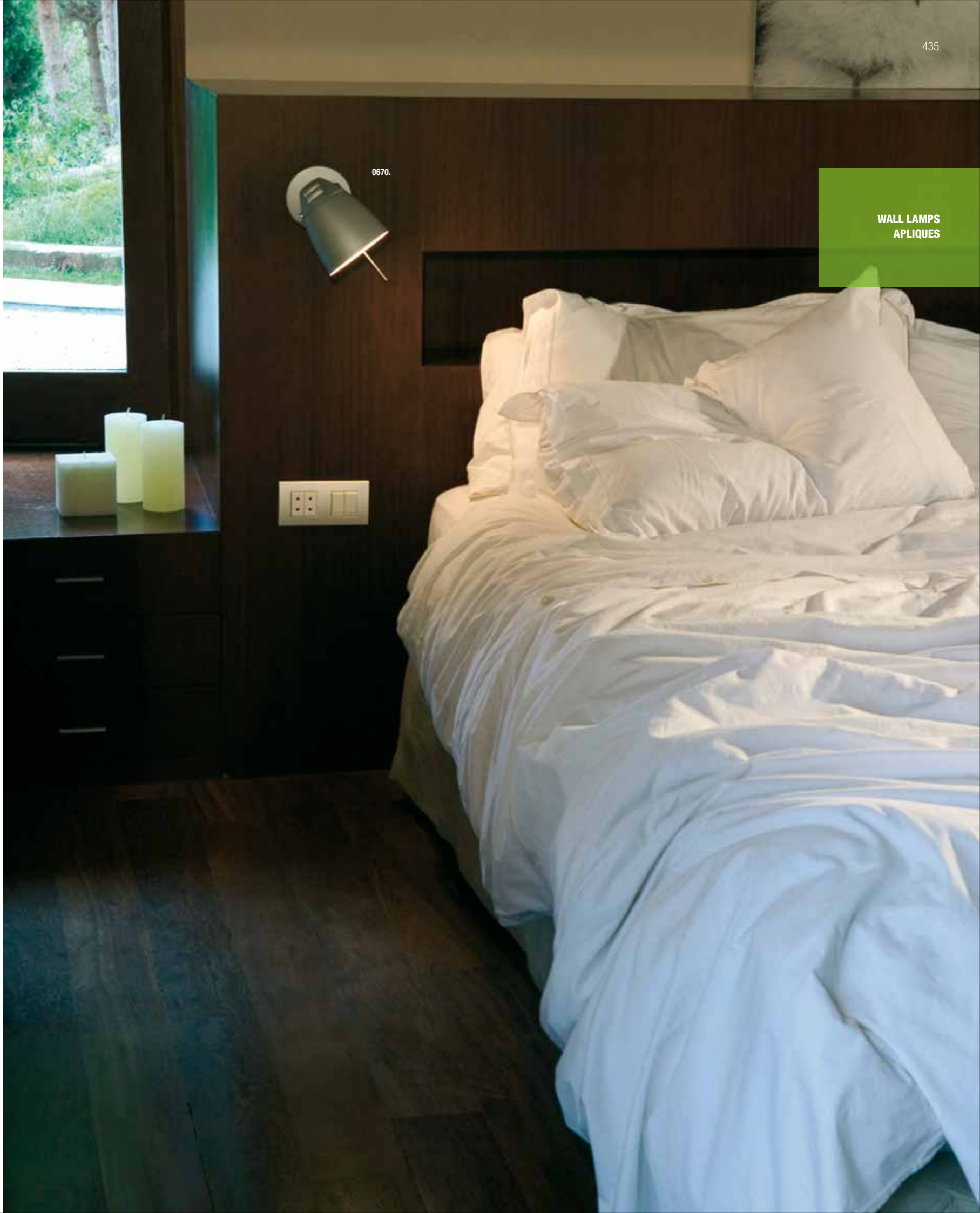



0665.



Chrome / Cromo



Silver lacquer / Lacado plata



Switch on top of the diffuser / Interruptor en la parte superior.



### Diva

**0665.**

Silver lacquer, chrome /  
Lacado plata, cromo.

E27 60W Max.

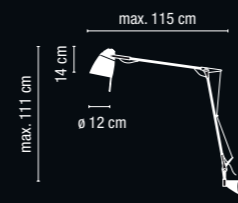

DIVA. Family / Familia  
Pages / Páginas: A-104. B-104. C-104. D-434. E-436.

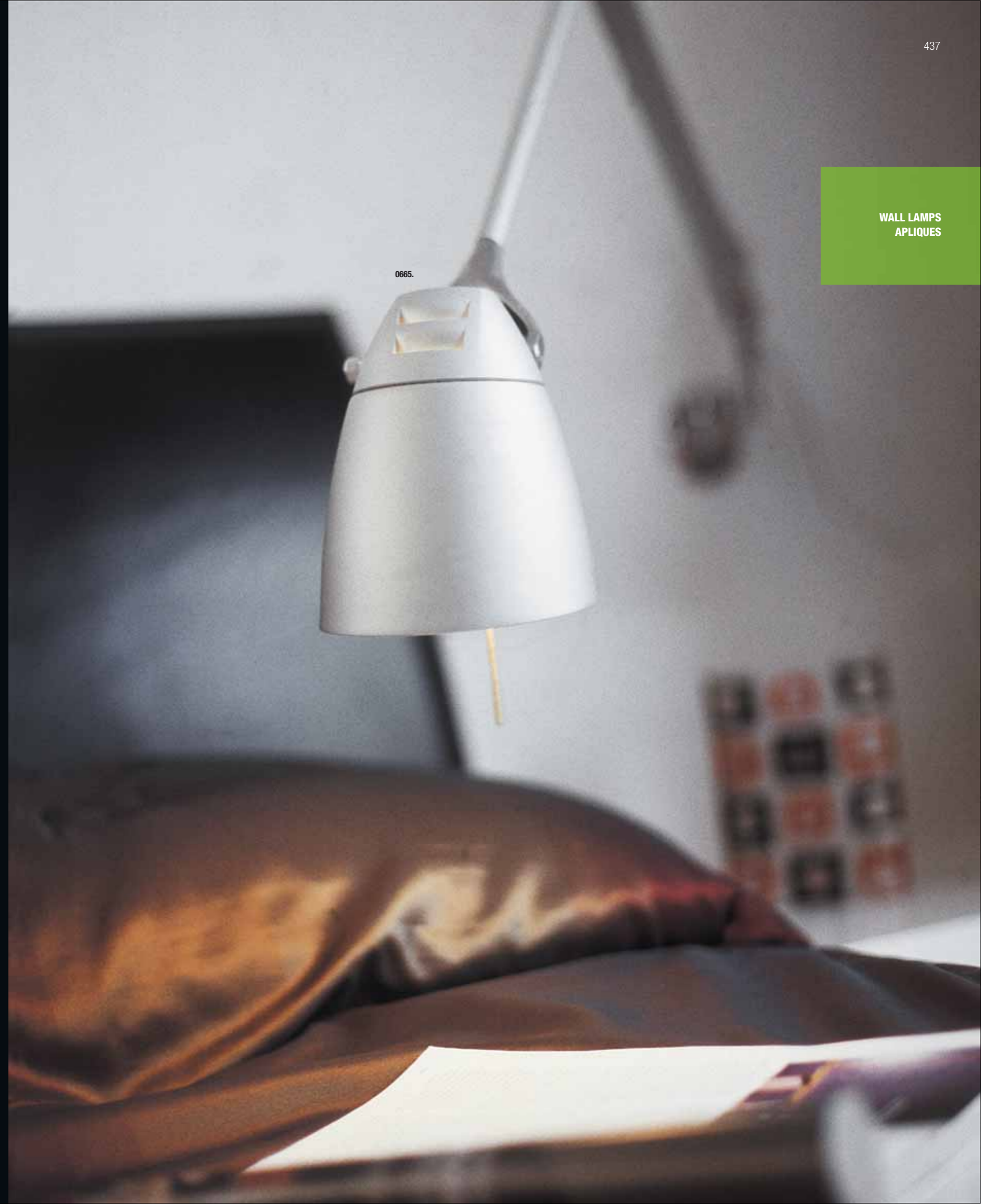

0665.



**Arms - Biluz**  
Design by Ramón Benedito.

**0211 / 0212.**  
Satin brass, matt nickel / Baño oro brossé, níquel mate .  
Fabric diffuser / Difusor de algodón.  
E27 Mate 230V 100W Max.  
E27  
GU4 12V 20W Max.  
GU4

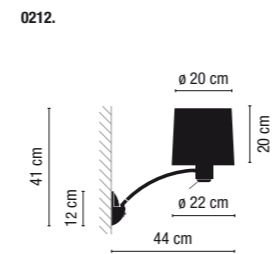
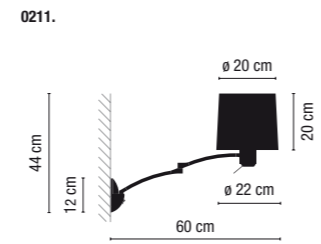

WALL LAMPS  
APLIQUES

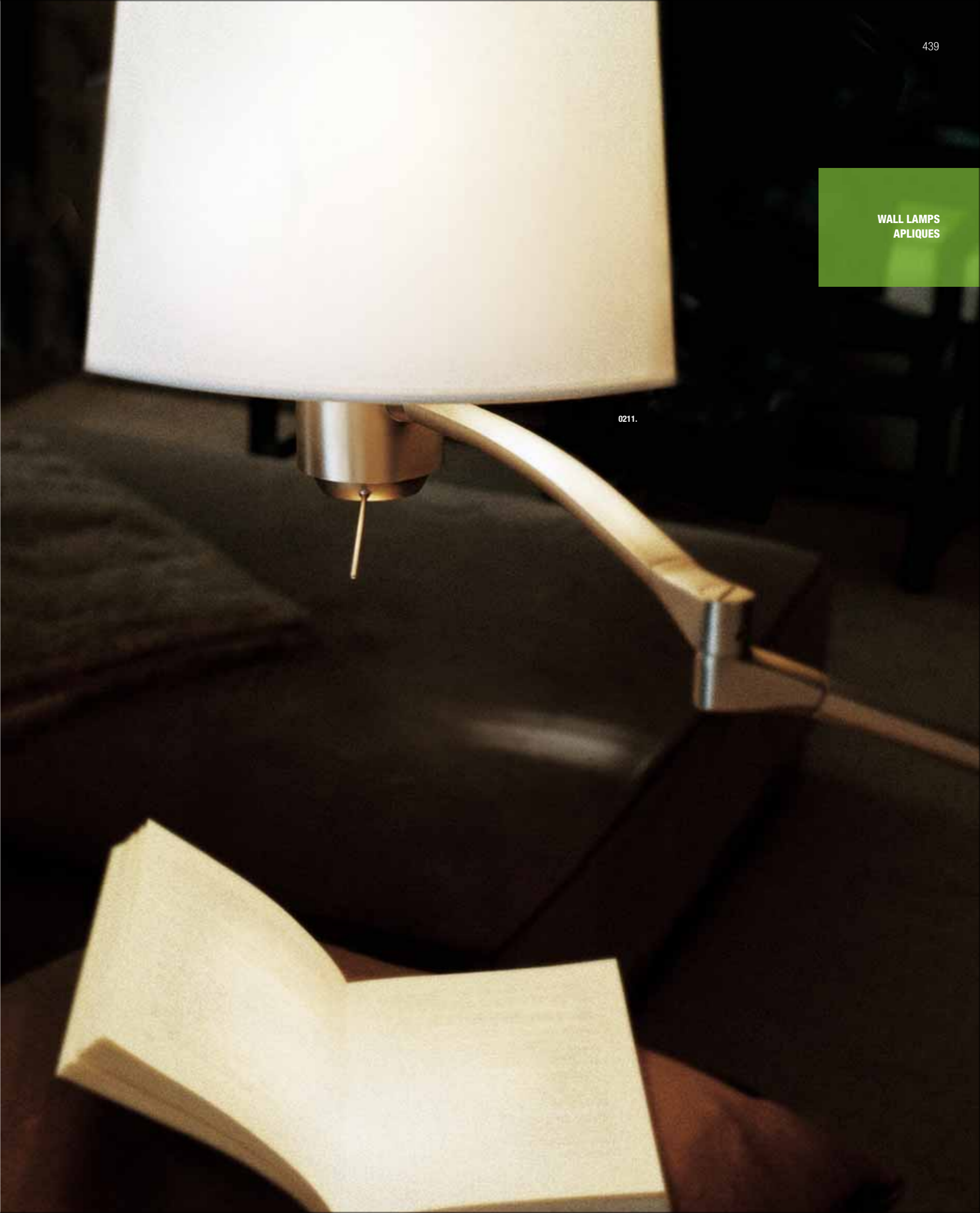

**Swing**  
Design by Lievore, Altherr, Molina.

**0511.**  
Chrome, matt nickel / Cromo, níquel mate.  
Fabric diffuser / Difusor de algodón.  
E27 Mate 230V 100W Max.  
💡

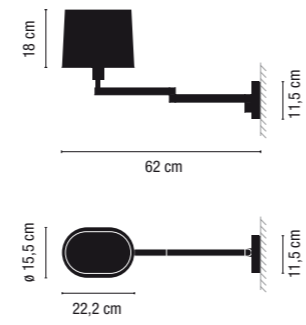

0511.



Chrome / Cromo.

Matt nickel / Níquel mate.

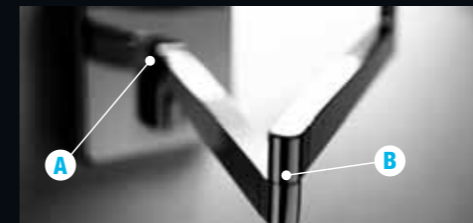

Double articulation (A+B) / Doble articulación (A+B).

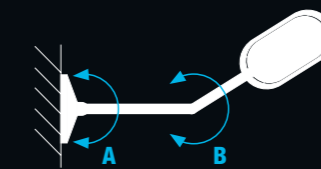

WALL LAMPS  
APLIQUES

0511.

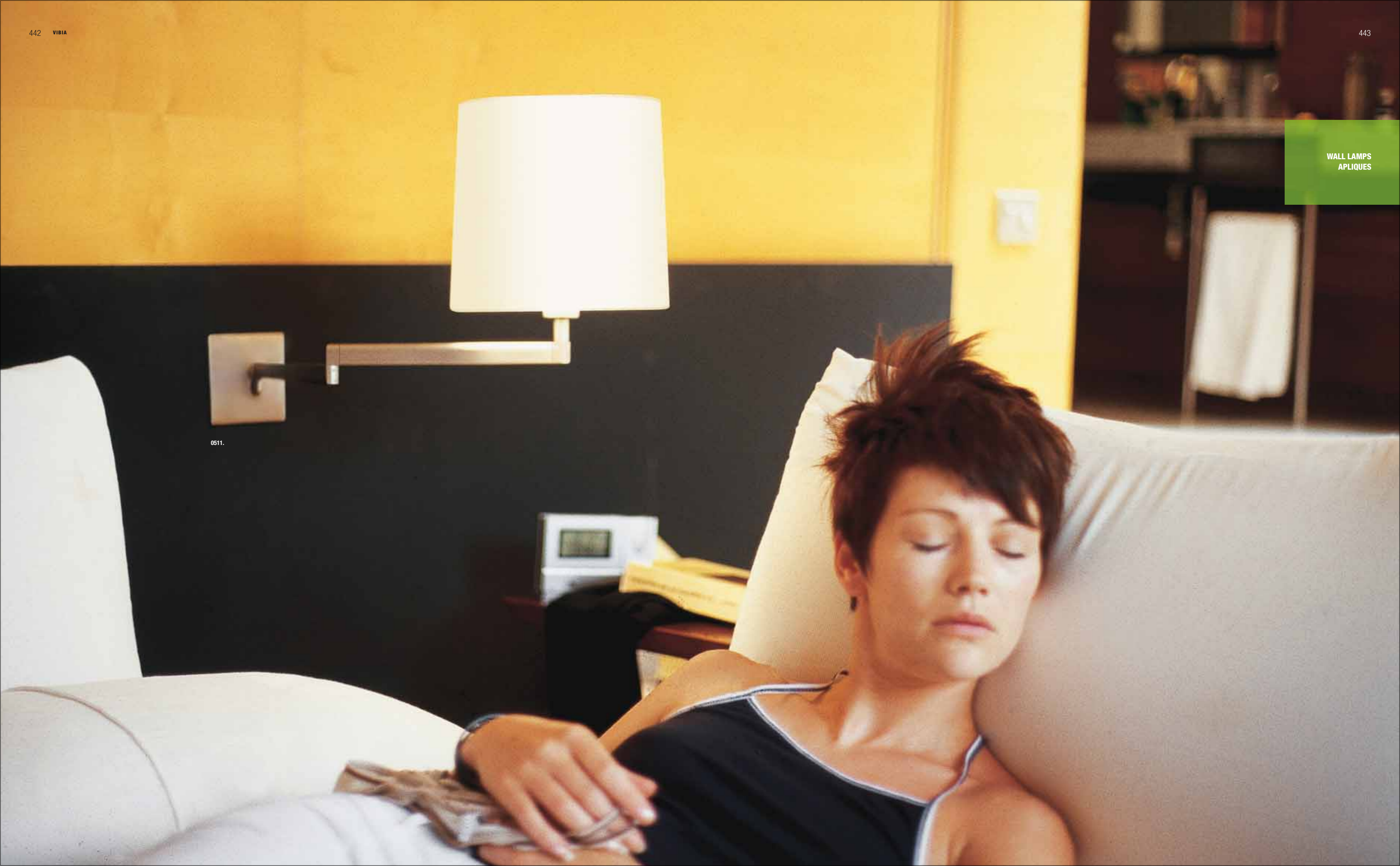



0525.

**Swing**  
Design by Lievore, Altherr, Molina.

**0525.**  
Matt nickel, chrome / Niquel mate, cromo.  
Orientable metal diffuser /  
Difusor de metal orientable.  
G9 230V 60W Max. (OSRAM HALOPIN)

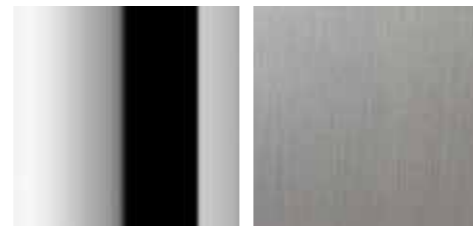
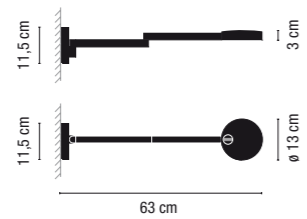

Chrome / Cromo.

Matt nickel / Niquel mate.



SWING. Family / Familia  
Pages / Páginas: A-62. B-66. C-116. D-114. E-440. F-444.

WALL LAMPS  
APLIQUES

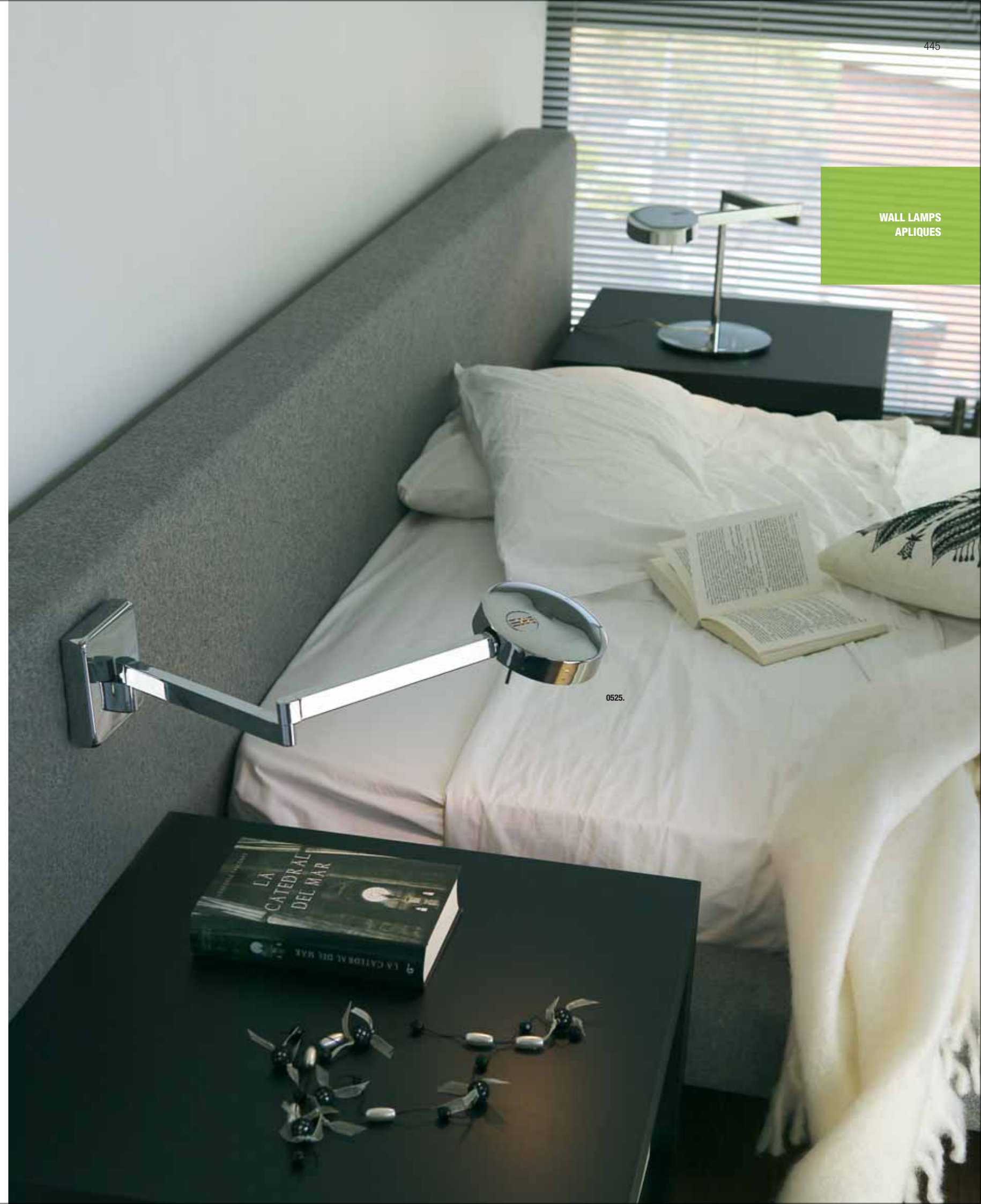

0525.

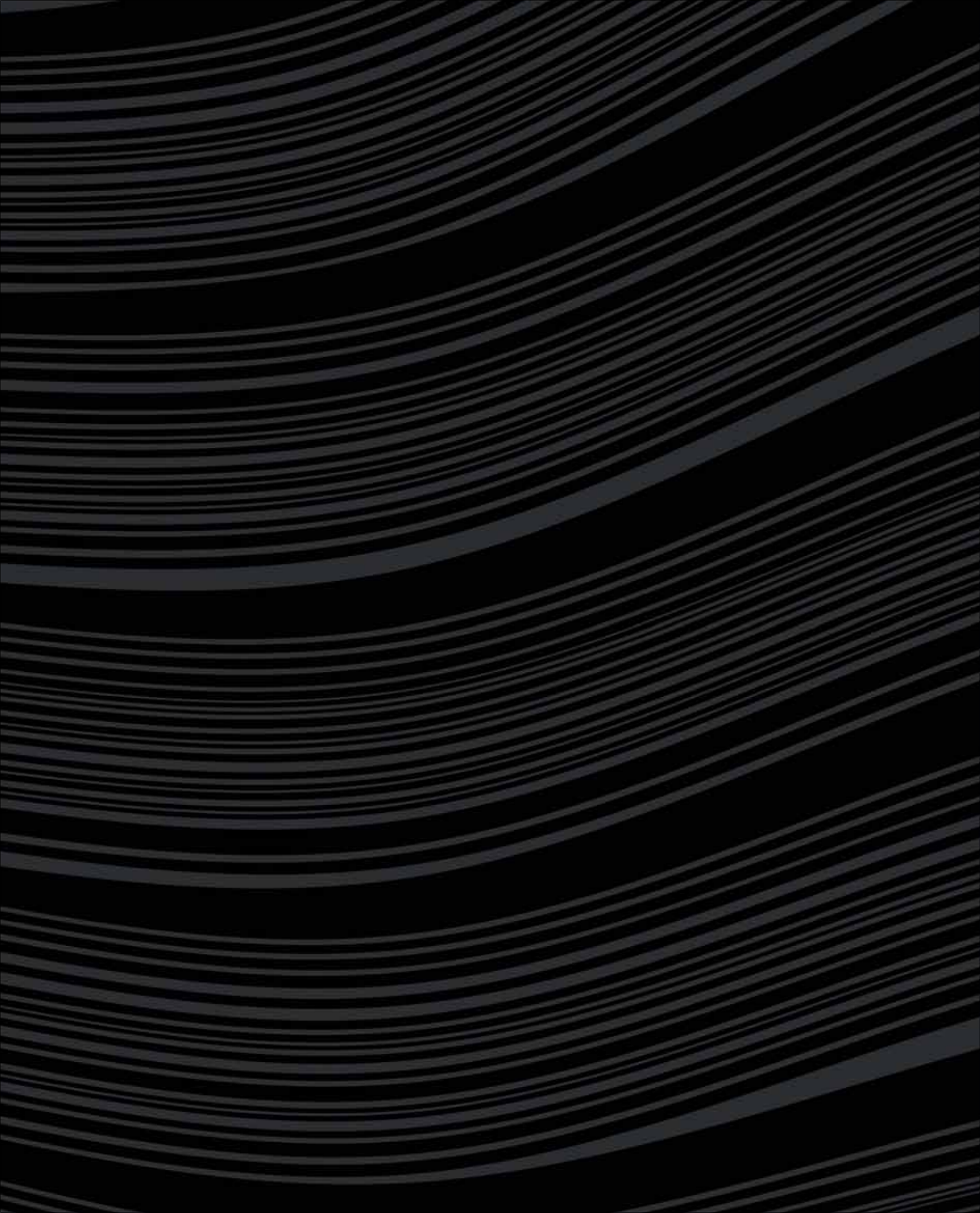

# Garden Jardin

Tree 452/456

GARDEN  
JARDIN





**Tree**

Design by Pete Sans.

**4000 / 4005 / 4010 / 4015.**

White lacquer or oxide / Lacado blanco o óxido.

Polyethylene diffuser / Difusor de polietileno.

**4000 / 4005:** 2 x 2G11 55W Max.



**4010:** E27 20W ( Osram Dulux E).



**4015:** E27 15W ( Osram Dulux E).



White lacquer /  
Lacado blanco.



Oxide / Óxido.

**4000.**

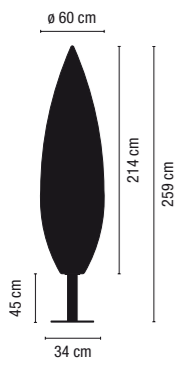

**4005.**

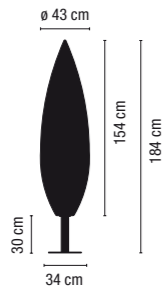

**4010.**

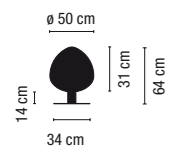

**4015.**

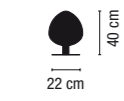

4010.



4015.



4005.



4000.



4015.

4005.

4005.

GARDEN  
JARDIN

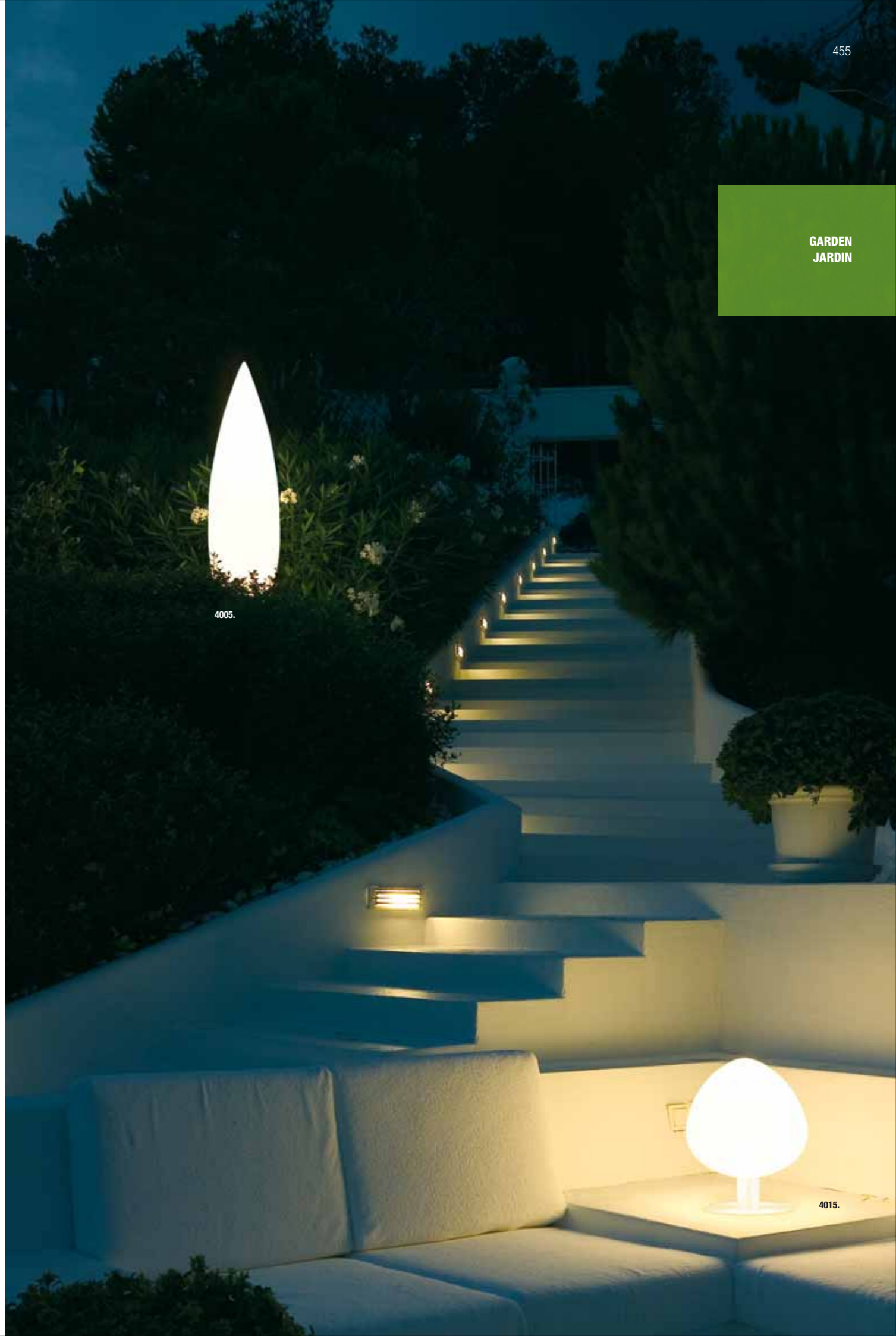

4015.

**Tree**

Design by Pete Sans.

**4020.**

White lacquer or oxide / Lacado blanco o óxido.

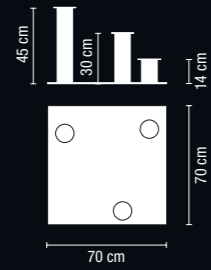

Triple composition:  
 Combinations between ref. 4000 / 4005 / 4010  
 Composición triple:  
 Combinaciones entre ref.4000 / 4005 / 4010.

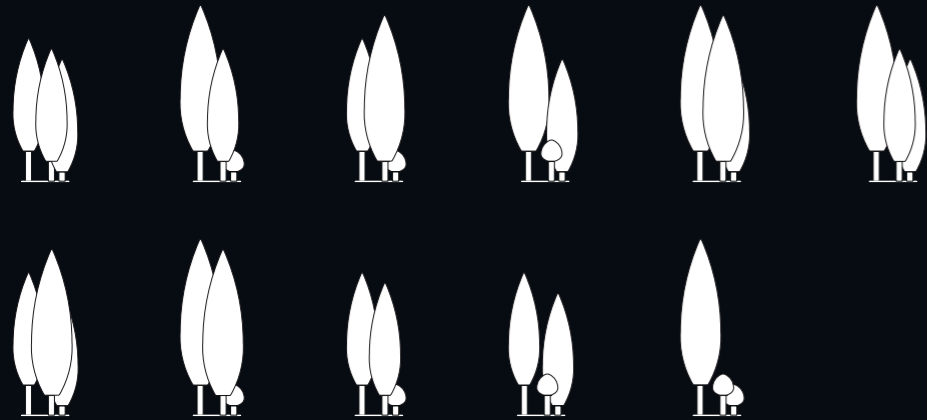

GARDEN  
JARDIN

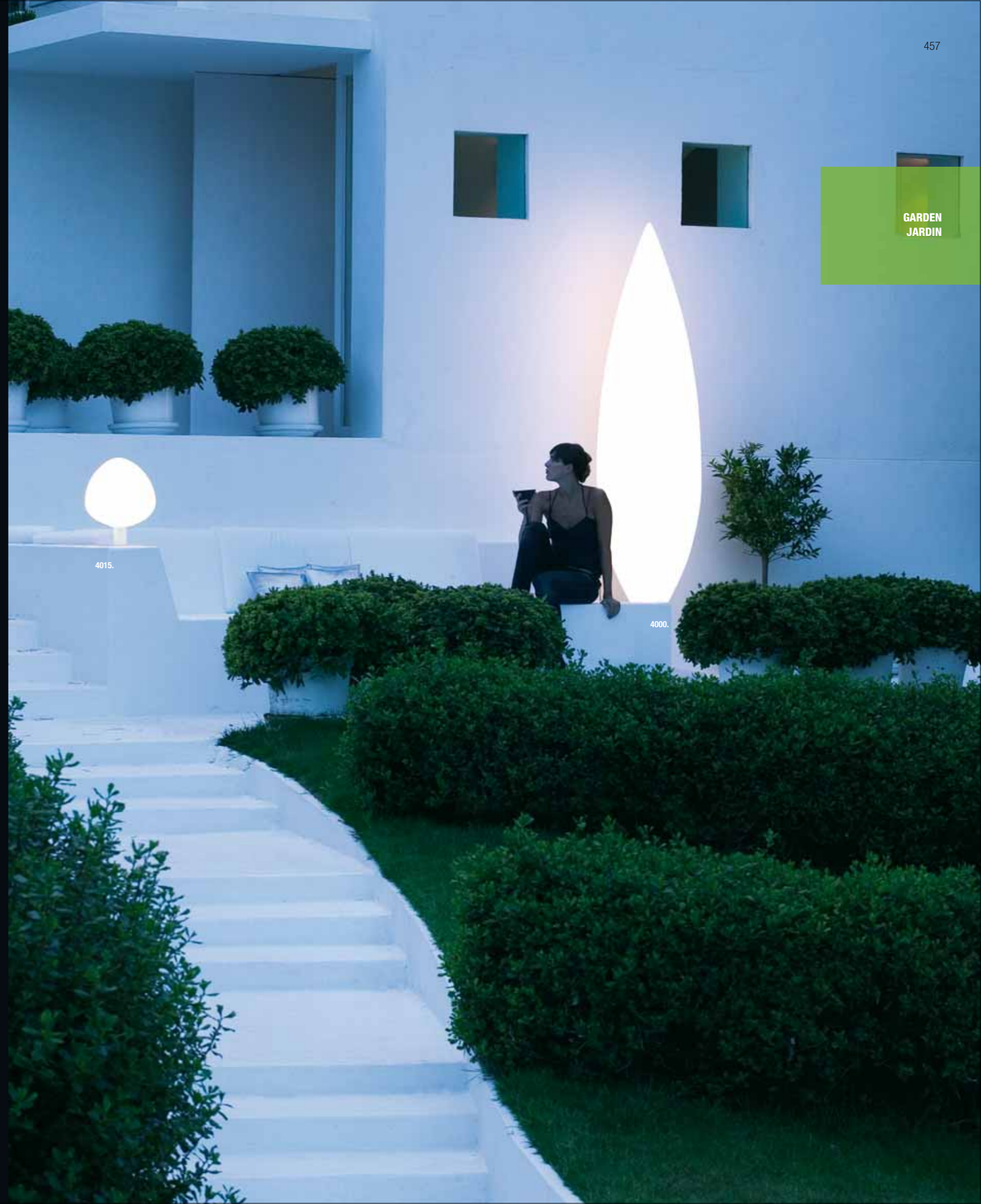





## Índice referencias / Item Index.

ref.	pag.	ref.	pag.	ref.	pag.	ref.	pag.	ref.	pag.	ref.	pag.	ref.	pag.
0211	438	1133	253	2102	139	5130	153	8033	354	8701	399		
0212	438	1134	253	2103	139	5135	426	8034	354	8702	399		
0351	106	1150	206	4000	452	5137	112	8038	357	8708	399		
0352	106	1185	178	4005	452	5138	112	8070	353	8720	399		
0355	166	1186	269	4010	452	5139	40	8071	353	8721	399		
0356	166	1187	269	4015	452	5140	38	8080	351	8751	399		
0361	422	1192	269	4020	456	5161	164	8081	351	8752	399		
0362	166	1195	178	4250	249/393	5163	164	8082	351	8753	399		
0501	62	1196	269	4251	249/393	5164	162	8090	349	8759	399		
0506	116	1250	412	4255	249/393	5166	162	8091	349	8771	399		
0511	440	1251	412	4308	260	5167	162	8092	349	8772	399		
0515	66	1275	420	4309	260	5169	162	8100	364	8800	315		
0520	114	1276	400	4310	260	5189	28	8101	365	8801	315		
0525	444	1281	400	4311	260	5190	28	8110	277	8803	314		
0530	224	1290	400	4312	260	5191	28	8111	277	8804	314		
0531	224	1291	400	4350	231/383	5192	28	8112	277	8826	314		
0550	13	1320	414	4351	231/383	5194	52	8115	278	8827	314		
0650	104	1325	414	4352	231	5195	52	8116	278	8840	321		
0652	104	1330	19	4353	231	5196	160	8117	278	8841	321		
0655	104	1331	89	4354	231	5197	160	8120	208	8842	320		
0665	436	1332	89	4355	237/384	5220	49	8121	208	8843	320		
0670	434	1333	85	4356	237/384	5222	125	8125	210	8895	315/323		
0675	120	1334	81	4357	237	5224	125	8126	210	8896	315/325		
0677	120	1335	186	4365	239/386	5226	184	8130	304	8900	325		
0682	42	1336	188	4366	239/386	5228	184	8131	304	8901	325		
0683	42	1337	190	4367	239	5230	60	8135	302	8902	325		
0686	430	1338	190	4370	235	5240	419	8136	302	8903	325		
0690	198	1370	79	4375	235/388	5245	408	8140	286	8906	323		
0901	144	1375	24	4400	245	5246	408	8141	286	8907	323		
0902	144	1380	157	4405	245	5257	410	8142	286	8908	323		
0903	148	1381	157	4410	243	5258	410	8143	286	8909	323		
0904	150	1405	170	4411	243	5259	46	8144	288	8920	329		
0905	432	1406	170	4414	243	5262	425	8145	284	8921	329		
0950	404	1445	50	4415	243	5263	410	8146	284	8922	329		
0951	406	1449	102	4425	247	5280	22	8147	284	8923	329		
0952	404	1459	180	4426	247	5285	91	8148	284	8924	329		
0953	406	1460	180	4427	247	5290	158	8149	288	8925	329		
0975	378	1465	180	5028	118	5291	158	8160	54	8926	329		
0976	378	1505	128	5030	58	5300	335	8161	54	8927	329		
0977	378	1506	128	5031	118	5301	335	8400	256/390	8932	294		
1015	338	1600	200	5032	168	5302	335	8407	297	8933	294		
1016	338	1601	200	5065	92	5303	335	8490	266	8938	294		
1017	338	1602	200	5066	92	5310	335	8491	266	8939	294		
1018	338	1996	32	5070	192	5311	335	8492	266	8950	196		
1025	340	1997	34	5093	96	5312	335	8500	265/403	8951	196		
1026	340	1998	34	5101	227	5313	335	8502	265/403	8955	196		
1027	340	1999	37	5102	227	5320	69	8510	296	8956	196		
1028	340	2004	218/370	5103	227	5330	172	8520	428	8960	310		
1033	343	2005	222	5110	99	5331	172	8600	395	8961	310		
1034	343	2006	222	5111	99	5332	172	8604	243/395	8970	308		
1035	343	2007	222	5112	99	5333	172	8606	245/395	8971	308		
1036	343	2010	375	5115	99	5335	174	8608	395	8980	308		
1037	343	2011	375	5116	99	5336	174	8614	397	8981	308		
1097	110	2020	140	5117	99	5337	174	8620	290	8990	146/318/326		
1114	271	2021	140	5120	26	5338	174	8621	292	8991	146/318/326		
1115	271	2060	183	5121	26	5340	177	8622	290	8992	146/318/326		
1120	259	2061	183	5122	26	5341	177	8623	292	8993	319/327		
1121	259	2062	183	5124	153	5342	177	8630	275/417	8994	319/327		
1125	259	2080	194	5125	153	5343	177	8631	273/417	8995	319/327		
1128	253/390	2081	194	5126	153	8030	358	8632	275/417				
1129	253	2100	15	5128	153	8031	358	8633	273/417				
1132	253	2101	130	5129	153	8032	354	8700	399				



Etiqueta autoadhesiva que identifica el producto VIBIA.  
Sticker which identifies the VIBIA products.

VIBIA se reserva el derecho de efectuar cualquier modificación  
y anulación de los productos del catálogo vigente sin previo aviso alguno.  
The contents of this catalogue may be changed or cancelled at the discretion  
of the VIBIA management without prior notice.



[www.vibia.es](http://www.vibia.es) for professional users

**GRUPO T DIFFUSION, S.A.**

Barcelona, 72 - 74.  
08820 El Prat de Llobregat  
(Barcelona - Spain).

**Nacional**

Tel 93 479 6970. Fax 93 479 6973.

**International**

Tel 93 479 6971. Fax 93 478 2026.  
grupo-t@grupo-t.com

**VIBIA, INC. USA.**

272 Fernwood Ave.  
Edison, NJ 08837.  
Phone 732 417 170.  
Fax 732 417 1701.

