



arturo alvarez

arturo alvarez

emo
tional
light





“Ponemos toda nuestra ilusión y medios en ofrecer diseños hechos a mano, cuidados en todos sus detalles, que sean capaces de satisfacer necesidades lumínicas y emocionales del ser humano”

“We put all our hopes and resources to provide with hand-made designs, meticulous in every detail and able to fulfill all the lighting and emotional needs of any human being”

índice index

arturo alvarez

06 arturo alvarez	08 shio	16 gea	22 nevo	30 uxi	34 hexa	36 planum
40 metrica	46 vento	54 norman	60 nim	66 curvas	72 gilda	78 gluc
82 doscubos	86 cebra	88 sophi	92 encaixe	96 domino	98 greta	102 kono
	104 senda	106 sombras	108 apliques/ plafones wall lamps/ ceiling lamps	110 exterior	112 ventopop	
117 lab	118 aros	124 fluo	130 guau	136 v	142 bety	148 lua
			154 iki			
161 contract	165 directorio técnico technical directory	187 leyenda de símbolos symbol index	188 créditos & contacto credits & contact			





arturo alvarez,
una empresa
dinámica y
alternativa
que apuesta
por el diseño
en iluminación
contemporánea

arturo alvarez, se dedica al diseño, desarrollo e investigación en iluminación contemporánea, nace en el noreste de España, en Santiago de Compostela, en el año 1994.

arturo alvarez crea objetos de gran personalidad, únicos, para entornos privados y públicos que han logrado conectar con las necesidades e intereses de cientos de personas.

Un equipo profesional, altamente cualificado, junto a diseñadores de primera línea, a cuya cabeza está el director creativo de la empresa Arturo Álvarez, dan vida a un proyecto claro y sólido.

Distintos premios de diseño, de carácter internacional, conseguidos estos últimos años y la presencia cada vez mayor en las principales ciudades del mundo avalan el buen hacer de esta empresa.

arturo alvarez,
a dynamic and
alternative
company
committed to
the design of
contemporary
lighting

arturo alvarez is dedicated to the design, development and investigation in contemporary illumination. The company was founded in the Northwest of Spain, in Santiago de Compostela, in 1994.

arturo alvarez creates objects of great personality, unique, for private and public environments and able to connect with the needs and interests of hundreds of persons.

A highly qualified and professional team with first class designers, led by the creative director of the company, Arturo Alvarez, lives up a clear and solid project.

Different international design awards, obtained in the last few years and the increasing presence in the main cities of the world answer for the goodwill of this company.

shio

8

AÑO/YEAR
2010

TABLERO MARINO: Barras de tablero marino usadas de una nueva manera, con sus capas a la vista y colores laterales diferentes conforman bellas formas por cuyas ranuras escapa la luz. Esta nueva innovación tiene como meta caminar hacia diseños más ecológicos y sostenibles.

LAMINATED BOARD: Bars in laminated board used in a new way, with its layers in full view and different colours aside compose beautiful forms with the light filtering through its spaces. The aim of this new innovation is to obtain more ecological and sustainable designs.

Una forma universal, amable, unida a la belleza del nuevo uso dado al tablero marino, una sucesión de líneas con curva que dan fuerza y dinamismo a una colección versátil y cálida.

A universal shape, gentle, combined with the beauty of a new use given to laminated board, a sequence of layers in a curved shape giving power and dynamism to a warm and multi-purpose collection.

9

arturo alvarez



shio



↑ SH04 (Ø49x16.5 | h:150 cm)

arturo alvarez



↑ SH04-1 (Ø35x13 | h:150 cm)

shio



↑ SH02 (Ø34x13 | h:39 cm)

arturo alvarez

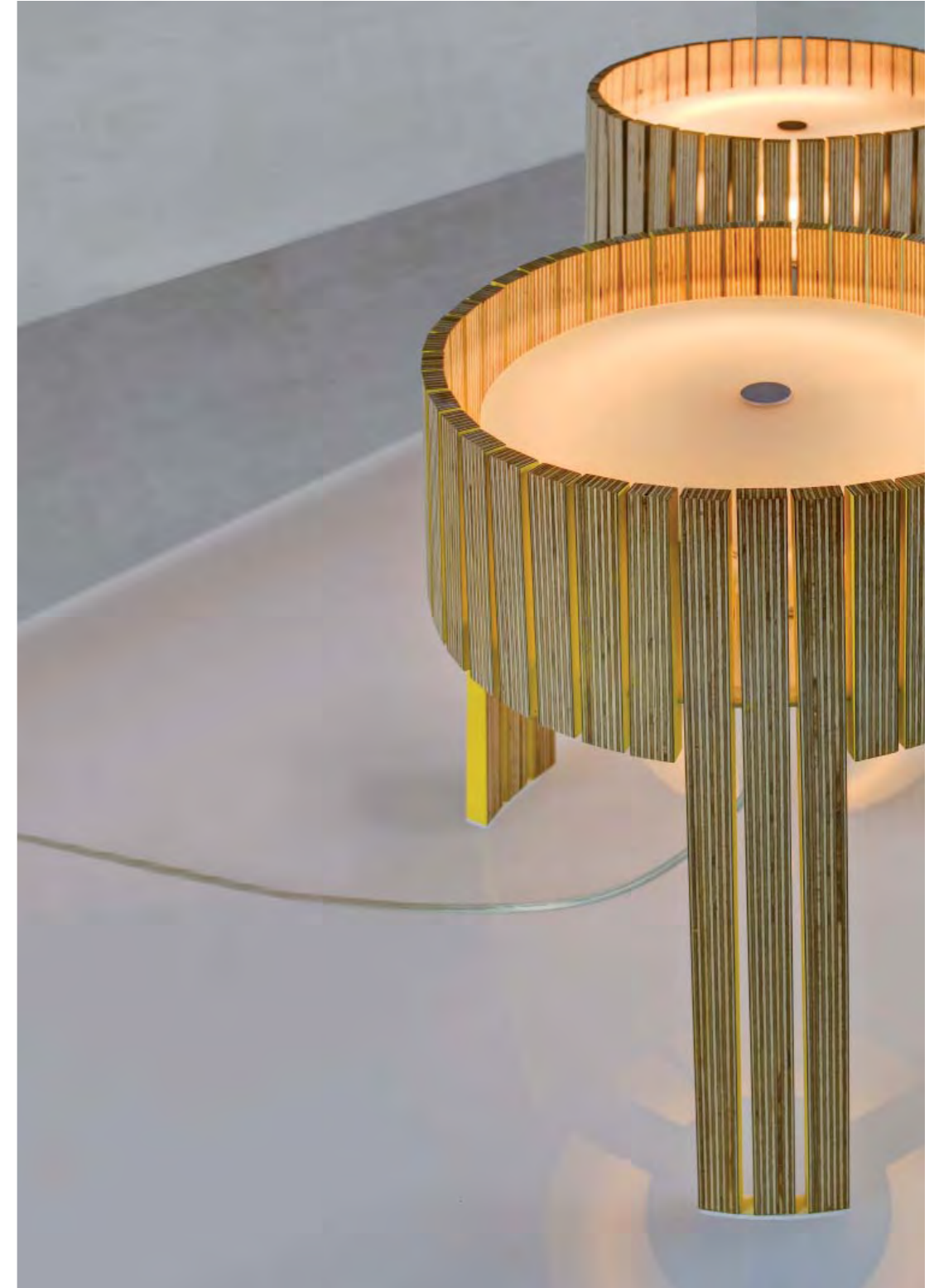

↑ SH02 DETALLE SUPERIOR / SH02 TOP DETAIL

shio



↑ SH03 (Ø52x16.5 | h:140 cm)

arturo alvarez



↑ SH06 (48x10x16.5mm)

↓ DETALLE ACABADO MADERA / WOOD FINISH DETAIL

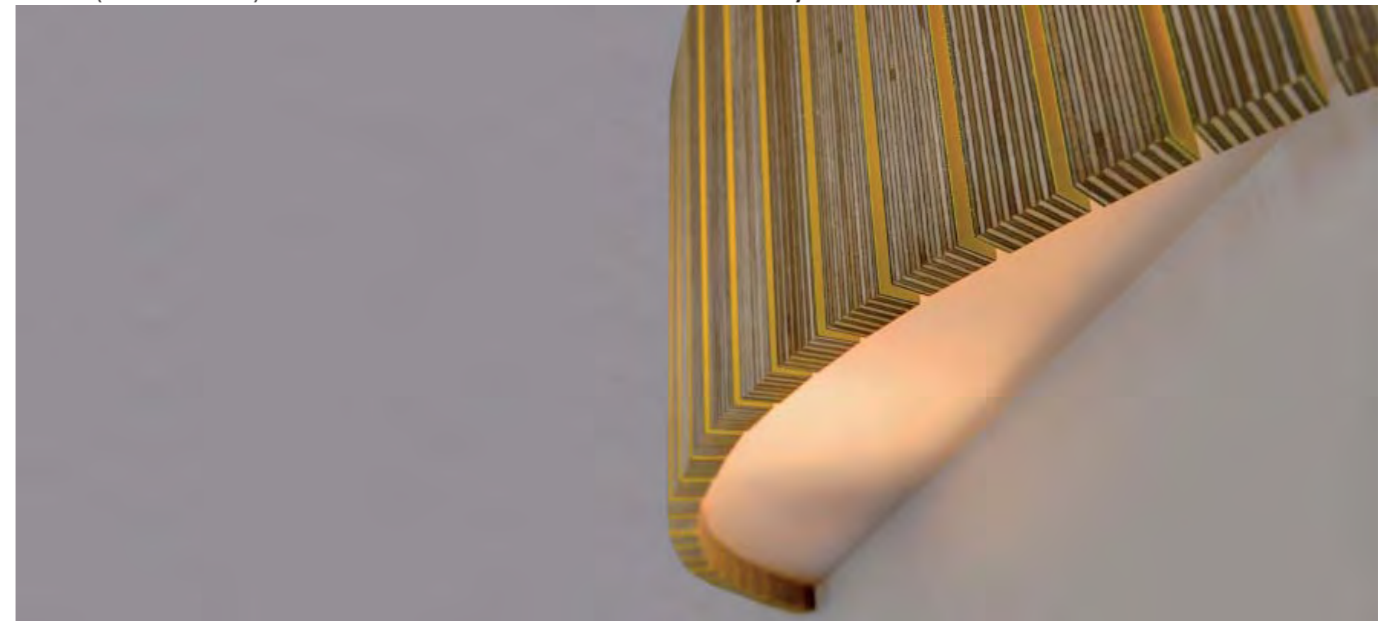

gea

16

AÑO/YEAR
2007

MALLA CON SILICONA:
Arturo Álvarez desarrolla un nuevo material a partir de la exploración y mezcla de materiales cotidianos, así surge la combinación de malla metálica con silicona: flexible, lavable, moldeable permite conseguir grandes volúmenes, plisados aportando una luz muy cálida y envolvente.

MESH WITH SILICONE:
Arturo Alvarez develops a new material from the exploration and mixture of daily life materials, in that way appears the combination between metallic mesh and silicone: flexible, washable, malleable so it allows to obtain big volumes, pleated so to provide with a very warm and wrapping light.

Una forma sinuosa que proporciona una luz indirecta y envolvente. Una pieza que llena los espacios de una luz suave y agradable, fácilmente combinable y que se mimetiza en cualquier ambiente.

A sinuous shape that provides indirect, enveloping light. A lamp that fills spaces with a soft and pleasant light, easy to combine and able to achieve empathy with any environment.



2008

arturo alvarez

17



gea



↑ GE03 (28x180x22 cm)

arturo alvarez



↑ GE01 (13x72x12 cm)



↑ DETALLE CREMALLERA / ZIP DETAIL

gea

arturo alvarez



↑ GE04 (Ø16x45 | h:150 cm)



↑ GE03 (28x180x22 cm)

nevo

22

AÑO/YEAR
2007

Una forma viva que parece en constante evolución. Una nube de curvas sugerentes, de volúmenes imposibles en la que el futuro se entrelaza con el presente de forma sutil. Una forma desacomplejada trabajada con materiales de última generación.

A vibrant shape that seems to be constantly changing. A cloud of suggestive curves, of impossible volumes where the future intersects with the present in a subtle way. A self-confident shape made of cutting-edge materials.

23

arturo alvarez

MALLA CON SILICONA:
Arturo Álvarez desarrolla un nuevo material a partir de la exploración y mezcla de materiales cotidianos, así surge la combinación de malla metálica con silicona: flexible, lavable, moldeable permite conseguir grandes volúmenes, plisados aportando una luz muy cálida y envolvente.

MESH WITH SILICONE:
Arturo Alvarez develops a new material from the exploration and mixture of daily life materials, in that way appears the combination between metallic mesh and silicone: flexible, washable, malleable so it allows to obtain big volumes, pleated so to provide with a very warm and wrapping light.



nevo



↑ NE04G (Ø100x30 | h:200 cm)

↑ NE04-1 (Ø47x22 | h:150 cm)

↑ NE04 (Ø70x25 | h:150 cm)

arturo alvarez

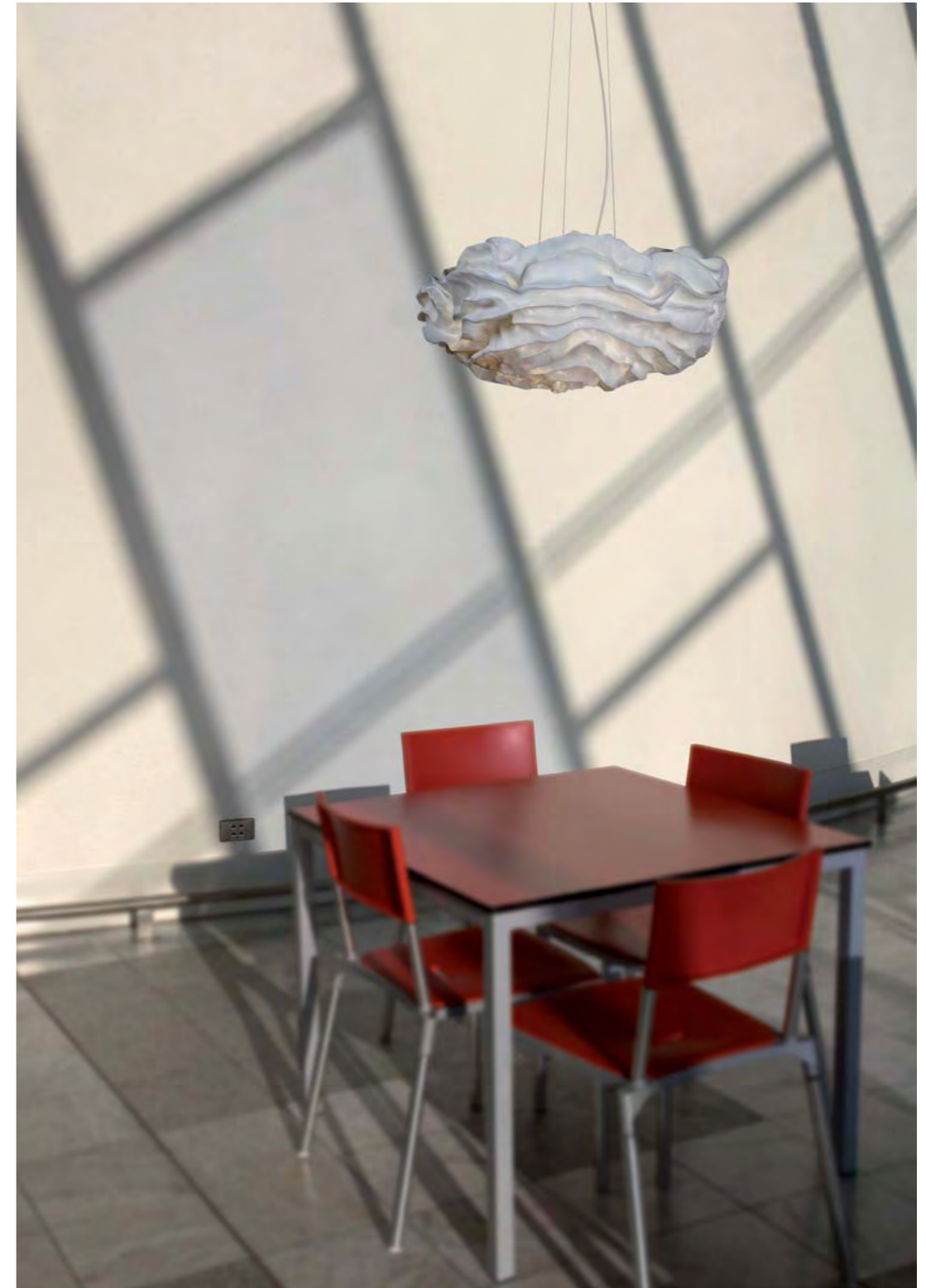

↑ NE04 (Ø70x25 | h:150 cm)

nevo

AÑO/YEAR
2009

arturo alvarez



↑ NE01 (Ø28x15 | h:22 cm)



↑ NE02 (Ø47x22 | h:70 cm)

nevo



↑ NE06P (Ø28x15 cm)

↑ NE06 (Ø47x22 cm)

arturo alvarez

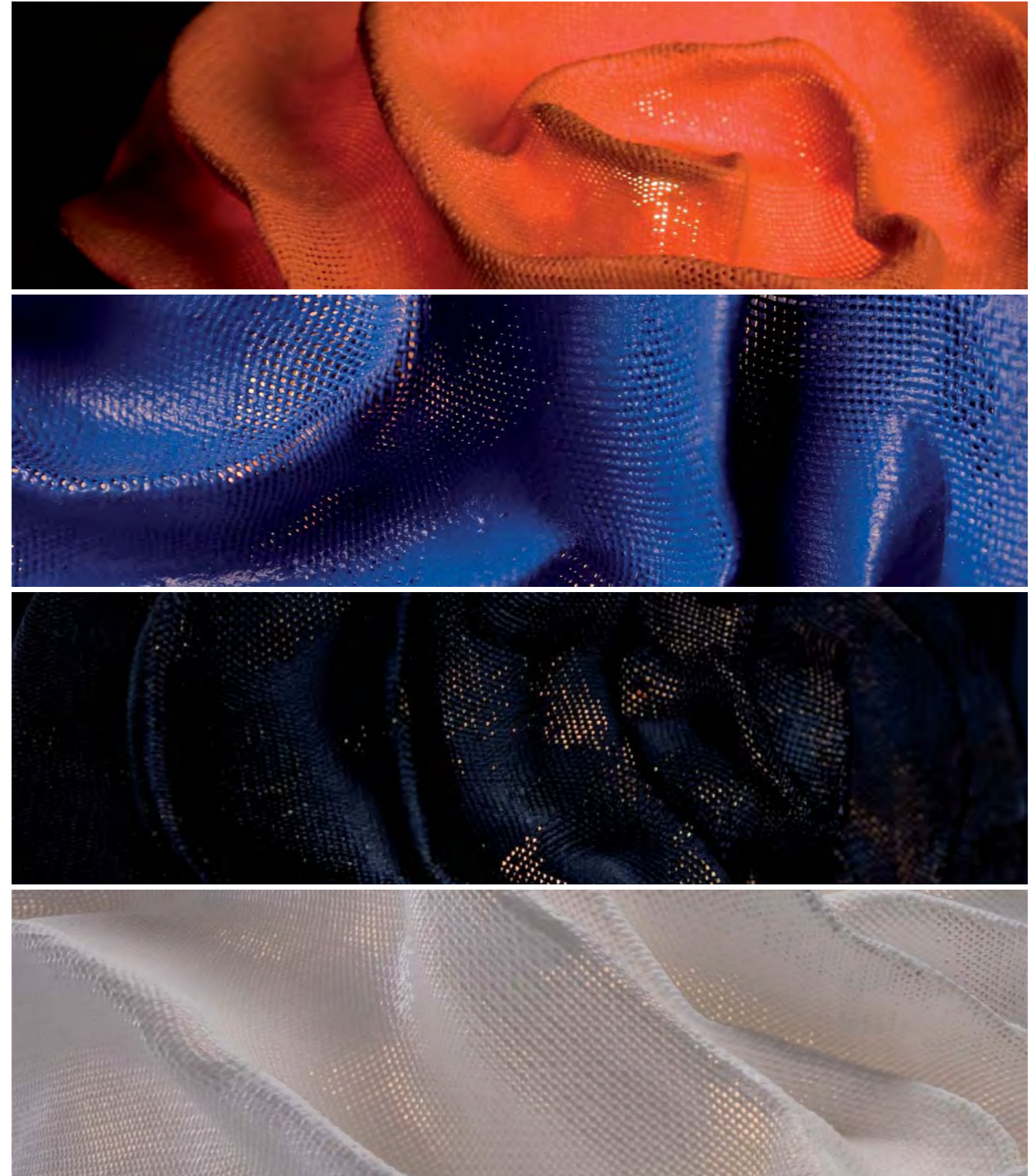

↑ DETALLE DE LOS COLORES DE SILICONA / SILICONE COLOUR DETAILS

La belleza y calor de la madera surge a través de una forma sinuosa, formada por una sucesión de barritas de tablero marino, por las que se escurre la luz de forma sutil.

The beauty and warmth of the wood emerges between a sinuous shape, created by a succession of bars in laminated board. The light slips away in a subtle form in between them.

TABLERO MARINO: Barras de tablero marino usadas de una nueva manera, con sus capas a la vista y colores laterales diferentes conforman bellas formas por cuyas ranuras escapa la luz. Esta nueva innovación tiene como meta caminar hacia diseños más ecológicos y sostenibles.

LAMINATED BOARD: Bars in laminated board used in a new way, with its layers in full view and different colours aside compose beautiful forms with the light filtering through its spaces. The aim of this new innovation is to obtain more ecological and sustainable designs.



uxi

arturo alvarez



↑ UX06 (64x10.5x13 cm)



↑ DETALLE UX06 / UX06 DETAIL



↑ UX04 (98x20x13 | h:150cm)

hexa

34

AÑO/YEAR
2010

MALLA CON SILICONA:
Arturo Álvarez desarrolla un nuevo material a partir de la exploración y mezcla de materiales cotidianos, así surge la combinación de malla metálica con silicona: flexible, lavable, moldeable permite conseguir grandes volúmenes, plisados aportando una luz muy cálida y envolvente.

MESH WITH SILICONE:
Arturo Alvarez develops a new material from the exploration and mixture of daily life materials, in that way appears the combination between metallic mesh and silicone: flexible, washable, malleable so it allows to obtain big volumes, pleated so to provide with a very warm and wrapping light.

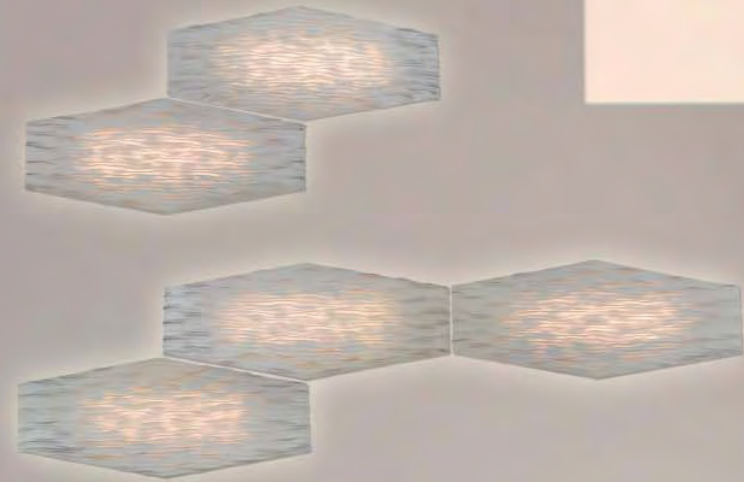

HE06 (96x47x8 cm)

35

La geometría se combina con la luz y una infinidad de composiciones posibles surgen para cubrir techos o paredes que recuerdan el orden y repetición armónica del universo y la naturaleza.

The geometry, mixed with the light and an infinity of possible combinations, arises to cover ceilings or walls, remembering the order and harmonic repetition of the universe and nature.

arturo alvarez



↑ HE06 (96x47x8 cm)

planum

36

AÑO/YEAR
2008

MALLA CON SILICONA:
Arturo Álvarez desarrolla un nuevo material a partir de la exploración y mezcla de materiales cotidianos, así surge la combinación de malla metálica con silicona: flexible, lavable, moldeable permite conseguir grandes volúmenes, plisados aportando una luz muy cálida y envolvente.

MESH WITH SILICONE:
Arturo Alvarez develops a new material from the exploration and mixture of daily life materials, in that way appears the combination between metallic mesh and silicone: flexible, washable, malleable so it allows to obtain big volumes, pleated so to provide with a very warm and wrapping light.



PM06R (96x96x8 cm)

PM06PR (96x47x8 cm)

37

Una pantalla que nos permite cubrir grandes superficies con una luz cálida y agradable. Delicadas formas planas con pequeños y sutiles relieves que nos permiten crear auténticos cielos de luz en ambientes arquitectónicos.

A diffuser that lets us cover large surfaces with a warm and pleasant light. Delicate shapes with small and subtle relief that allow us to create authentic skies of light in architectural atmospheres.

arturo alvarez



↑ PM06R (96x96x8 cm)

planum



↑ PM06R (96x96x8 cm)

arturo alvarez



↑ DETALLE TEXTURA SILICONA / SILICONE TEXTURE DETAIL



↑ PM06R (96x96x8 cm)

metrica

40

AÑO/YEAR
2009

MALLA CON SILICONA:
Arturo Álvarez desarrolla un nuevo material a partir de la exploración y mezcla de materiales cotidianos, así surge la combinación de malla metálica con silicona: flexible, lavable, moldeable permite conseguir grandes volúmenes, plisados aportando una luz muy cálida y envolvente.

MESH WITH SILICONE:
Arturo Alvarez develops a new material from the exploration and mixture of daily life materials, in that way appears the combination between metallic mesh and silicone: flexible, washable, malleable so it allows to obtain big volumes, pleated so to provide with a very warm and wrapping light.

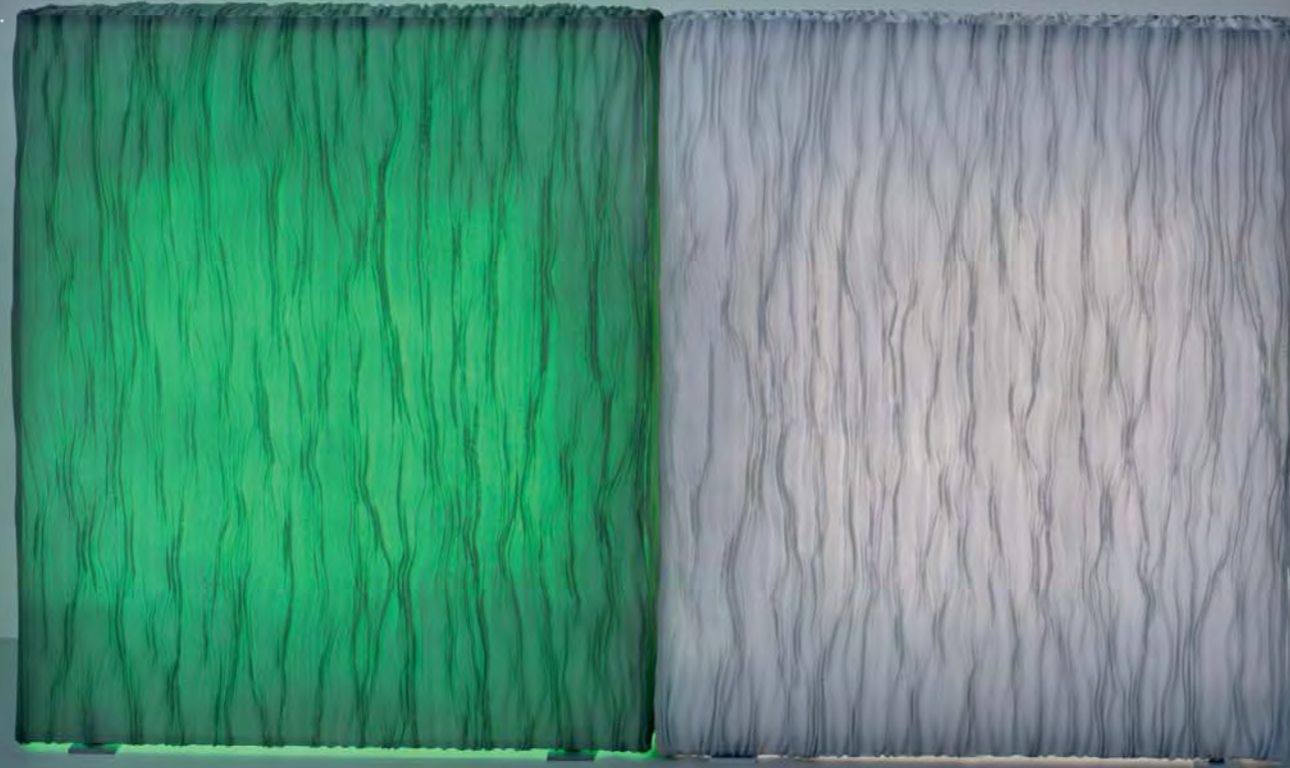

Pura arquitectura en la forma y en las aplicaciones posibles, formando mamparas de luz o por separado como pieza única. Una forma recta y simple que a la vez es cálida y amable para los sentidos.

Pure architecture in the form and in the possible applications, creating light screens or separately as a unique piece. A straight and simple form which at the same time is warm and kind for the senses.

41

arturo alvarez

metrica

arturo alvarez

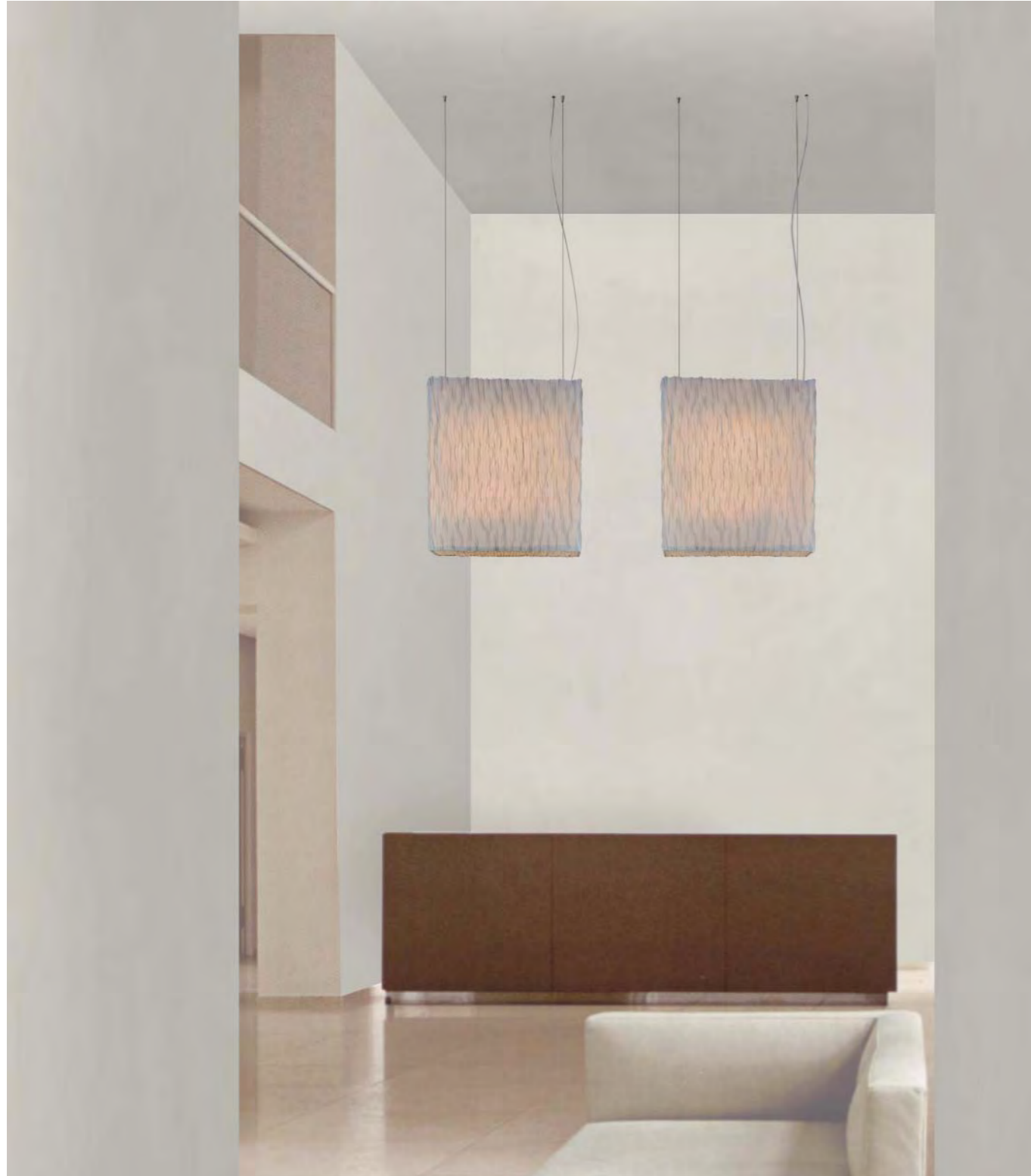

↑ MT04 (82x96x20 | h:250 cm)



↑ MT03 (82x96x20 cm)



Defendemos una producción hecha íntegramente en España. Nuestras materias primas provienen de Europa y EEUU

Toda la producción de arturo alvarez se hace en España y a mano, por personal experto y experimentado con la exigencia de cumplir con unos estándares de calidad y acabados muy altos.

Todos nuestros diseños están identificados con etiquetas propias y grabados con el nombre de la marca en las bases metálicas, para garantizar su autenticidad.

Tomando como criterio una alta calidad, defendemos la utilización única y exclusiva de las mejores materias primas provenientes de EEUU y países europeos como Alemania, Italia, Austria, Finlandia y España entre otros. Además, trabajamos con proveedores que garanticen el respeto y cumplimiento de normas socio-laborales y medio ambientales adecuadas.

We defend a production entirely manufactured in Spain. Our raw materials come from Europe and the USA

The production of arturo alvarez is entirely manufactured in Spain and hand-made by skilled and experienced staff, required to comply with very high quality standards and finishes.

All our designs are identified with labels and engraved with the brand name into the metal bases; everything is done to ensure the authenticity.

Considering the high level of quality as criteria, we defend the right to exclusively and uniquely use the best raw materials from the USA and European countries such as Germany, Italy, Austria, Finland and Spain. As well as to work with suppliers which guarantee respect and comply with the proper social, labour and environmental regulations.

vento

46

AÑO/YEAR
2005

VIDRIO ADHERIDO:
Aprovechando la belleza de las opalinas y con ánimo de ofrecer diseños más delicados y sutiles, suprimiendo la soldadura de estaño, surge la idea de utilizar la técnica de vidrio pegado, cuyas piezas se colocan adhiriéndolas a una estructura de metacrilato.

STICKED GLASS: By eliminating the solder, making the most of the beauty of glass and with the aim of offering more sensitive and subtle designs, arose the idea of using the technique of glued glass. These pieces are fixed on a methacrylate structure.

Un movimiento sinuoso como un viento suave que mece los árboles. Una forma que combina suaves curvas para crear una lámpara contundente. Un modelo en el que se reúnen placidez y sensación de calma gracias a su forma y a la mezcla de colores.

A sinuous movement like a soft breeze that rocks the trees. A shape that combines soft curves to create a powerful lamp. A model that mingles placidity and the sensation of serenity, thanks to its shape and mix of colours.

47

arturo alvarez



vento

arturo alvarez

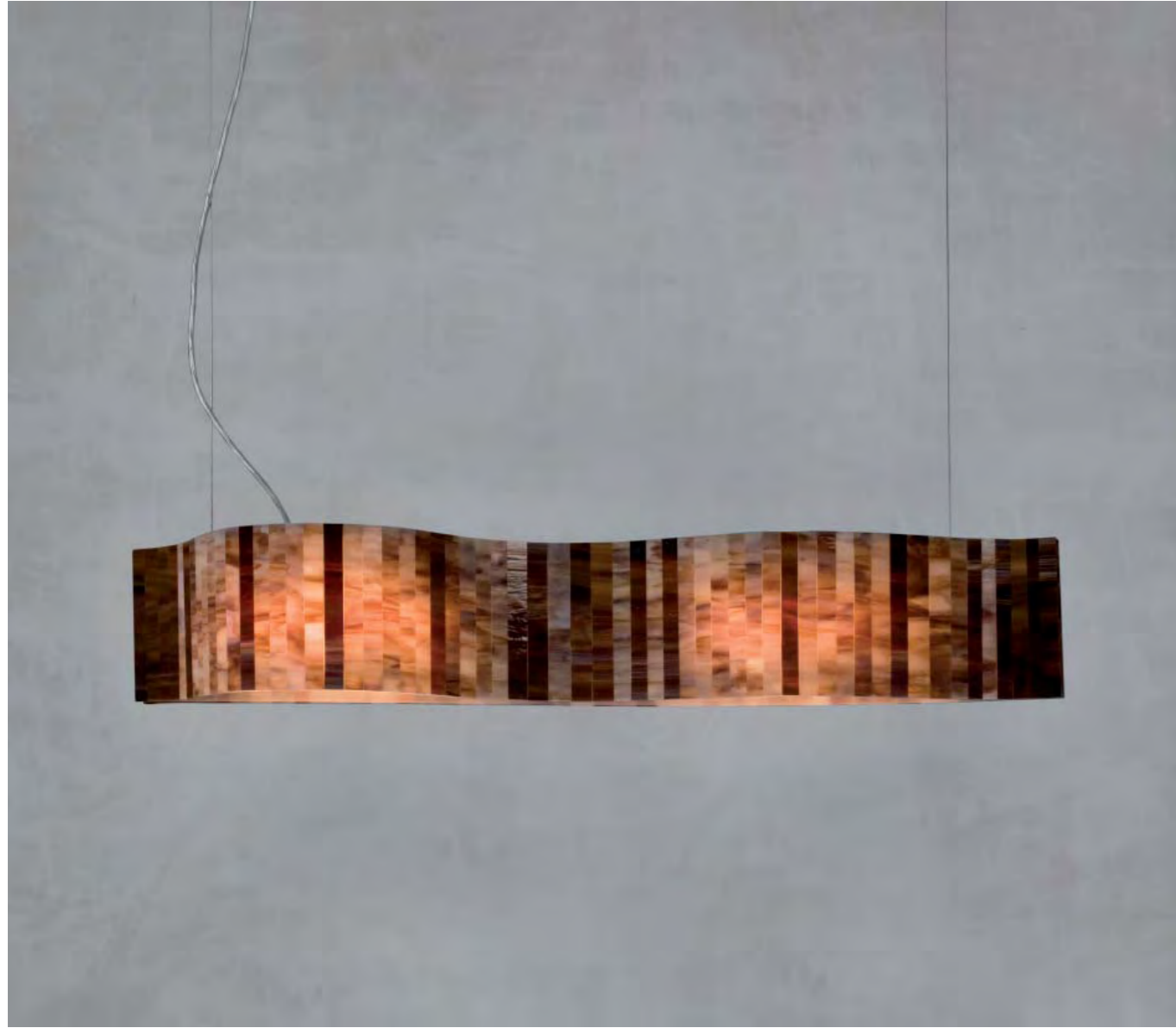

↑ VN04 (95x17x10 | h:150 cm)

↓ DETALLE MATERIAL / MATERIAL DETAIL



↑ VN04-1 (58x15x8 | h:150 cm)

vento

arturo alvarez



↑ VN01 (58x19x8 cm)

↑ VISTA CENTRAL / PLAN VIEW



↑ VN02 (95x21x10 cm)

vento



↑ VN06 (58x15x15 cm)

arturo alvarez



↑ VN06 (58x15x15 cm)



↑ DETALLE VISTA INFERIOR / BOTTOM VIEW

norman

54

AÑO/YEAR
2006

Una colección actual, de líneas contemporáneas, elegante y funcional. Un diseño atemporal de formas rectas que aporta soluciones para entornos íntimos y también para espacios públicos.

A collection for today, with contemporary lines that are elegant and practical. A timeless design with straight lines that provides with solutions for intimate environments and public spaces.

55

arturo alvarez

VIDRIO ADHERIDO: Aprovechando la belleza de las opalinas y con ánimo de ofrecer diseños más delicados y sutiles, suprimiendo la soldadura de estaño, surge la idea de utilizar la técnica de vidrio pegado, cuyas piezas se colocan adhiriéndolas a una estructura de metacrilato.

STICKED GLASS: By eliminating the solder, making the most of the beauty of glass and with the aim of offering more sensitive and subtle designs, arose the idea of using the technique of glued glass. These pieces are fixed on a methacrylate structure.

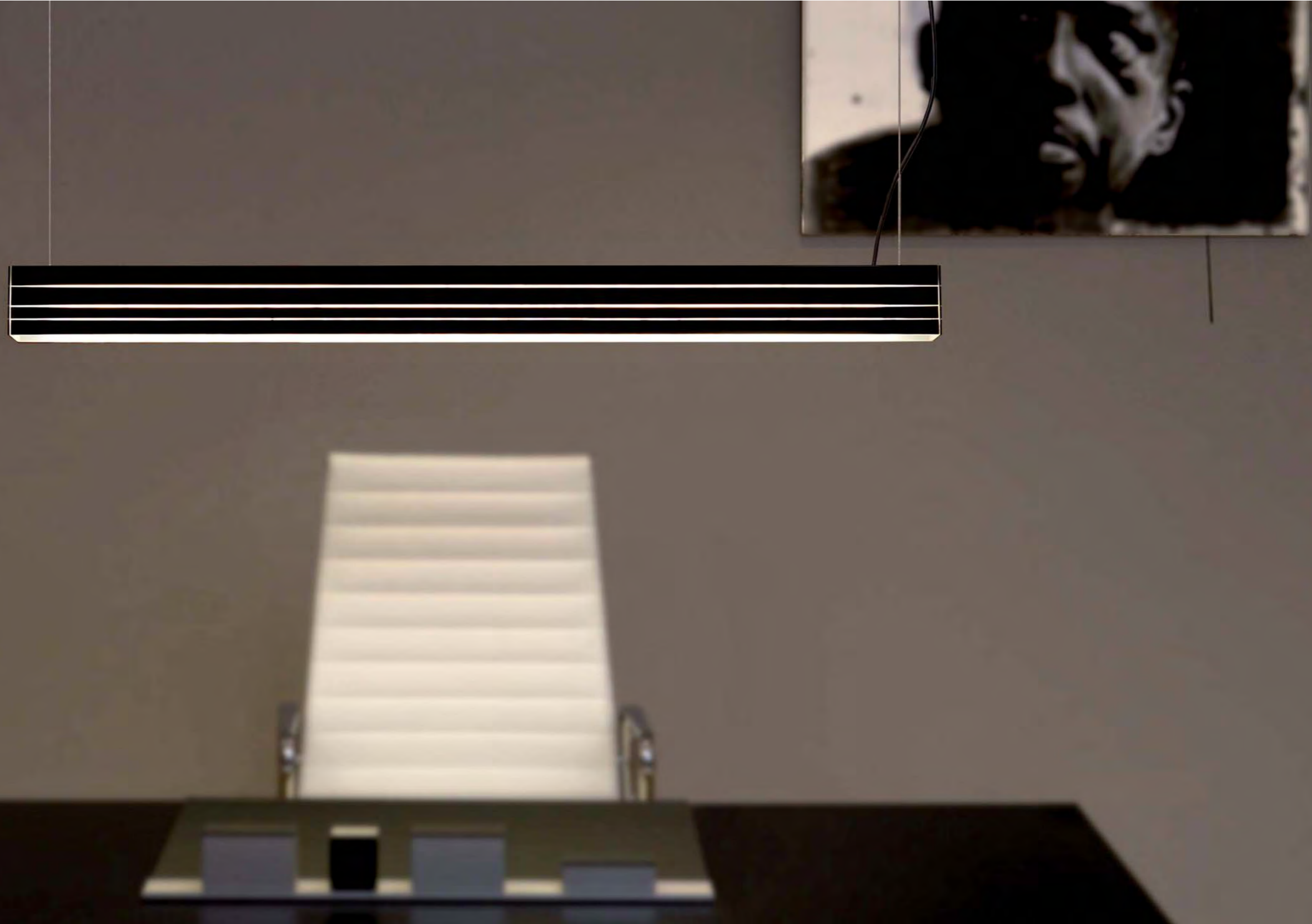

norman



↑ **N001** (27x15x7.5 | h:35 cm)

arturo alvarez



↑ **N004** (119x9.5x6.5 | h:150 cm)

norman



↑ NO06 (119x6.5x9.5 cm)

↓ DETALLE MATERIAL / MATERIAL DETAIL



arturo alvarez



↑ NO06P (30x6.5x9.5 cm)

nim

60

AÑO/YEAR
2008

Una forma reducida a la mínima expresión que se puede unir con distintas unidades, creando distintos volúmenes. Un juego de combinaciones que nos permite una disposición creativa y personal. ¿Qué es más importante: el todo o las partes?

A shape reduced to the minimum expression that can be used in series, creating different effects and forms. A set of combinations that allows for a creative and personal layout. What's more important: the whole or the parts?

61

arturo alvarez

VIDRIO ADHERIDO: Aprovechando la belleza de las opalinas y con ánimo de ofrecer diseños más delicados y sutiles, suprimiendo la soldadura de estaño, surge la idea de utilizar la técnica de vidrio pegado, cuyas piezas se colocan adhiriéndolas a una estructura de metal.

STICKED GLASS: By eliminating the solder, making the most of the beauty of glass and with the aim of offering more sensitive and subtle designs, arose the idea of using the technique of glued glass. These pieces are fixed on a metal structure.



NM04-1 (10x10x5.5 | h:150 cm)

nim



↑ NM04-4

arturo alvarez



↑ NM04-1 (10x10x5.5 | h:150 cm)

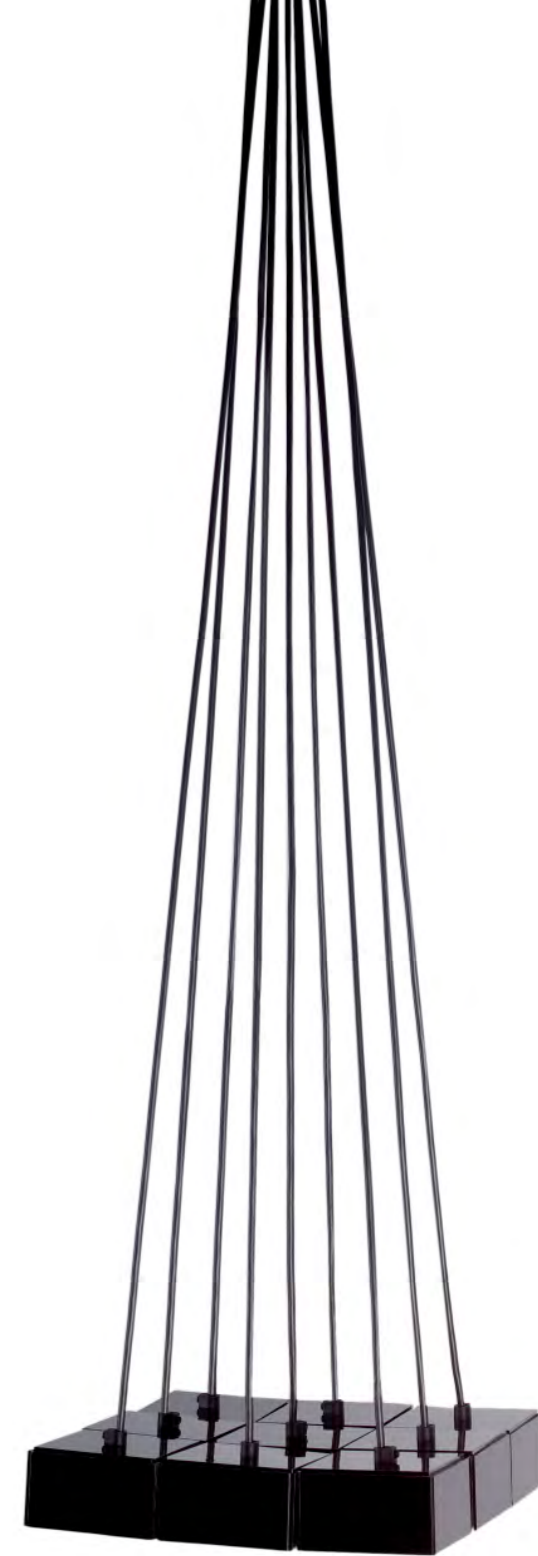

↑ NM04-9

nim

arturo alvarez



↑ NM01 (10x12x5.5 cm)

↓ NM06 (10x5.5x12 cm)

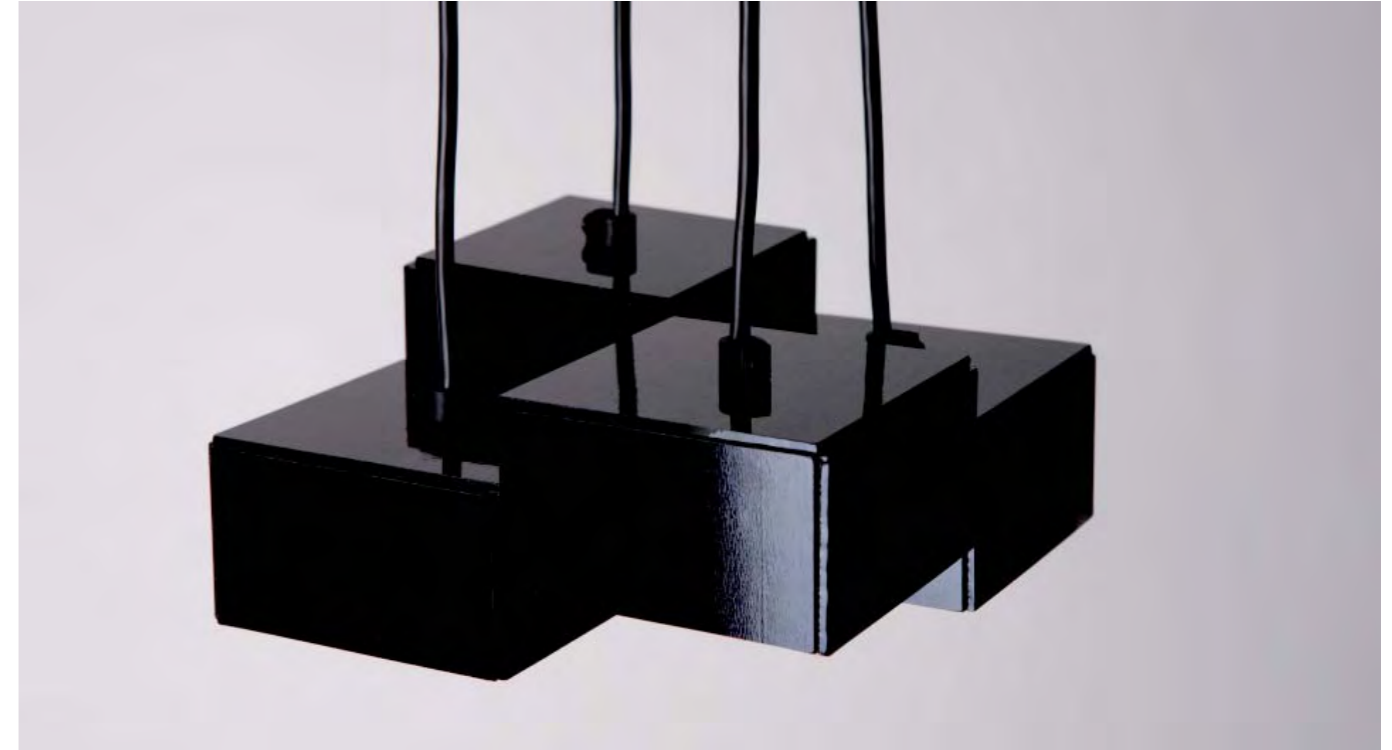

↑ NM04-4

↓ NM04-9



curvas

AÑO/YEAR
2004

Una irregularidad continua, piezas curvas que encajan unas con otras, un movimiento sutil, una sensación de bienestar. Una colección cálida y elegante.

A continuous irregularity, curved pieces that fit into each other in a subtle movement, a sensation of well-being. A warm and elegant collection.

arturo alvarez

VIDRIO ESTAÑADO: Arturo Álvarez reinventó la técnica tiffany, simplificando formas y colores, con un estilo único creó unos objetos contemporáneos muy simples. Las tulipas se hacen a partir de de las mejores opalinas de EEUU, que se cortan y se unen entre sí con estaño.

STAINED GLASS: Arturo Álvarez re-invented the Tiffany's lighting technique by simplifying forms and colours with his own style and created contemporary simple objects. The lamp shades are manufactured with the best US iridescent glasses, cut and soldered together.



curvas



↑ CV03G (Ø50x23 | h:165 cm)

arturo alvarez



↑ CV04G (Ø50x23 | h:150 cm)

↑ CV04 (Ø32x18 | h:90 cm)

CV04-1 (Ø15x11.5 | h:150 cm)↑

curvas



↑ CV01 (Ø15x11.5 | h:33 cm)

arturo alvarez



↑ CV06 (45x17x12 cm)

↓ CV06 DETALLE / CV06 DETAIL

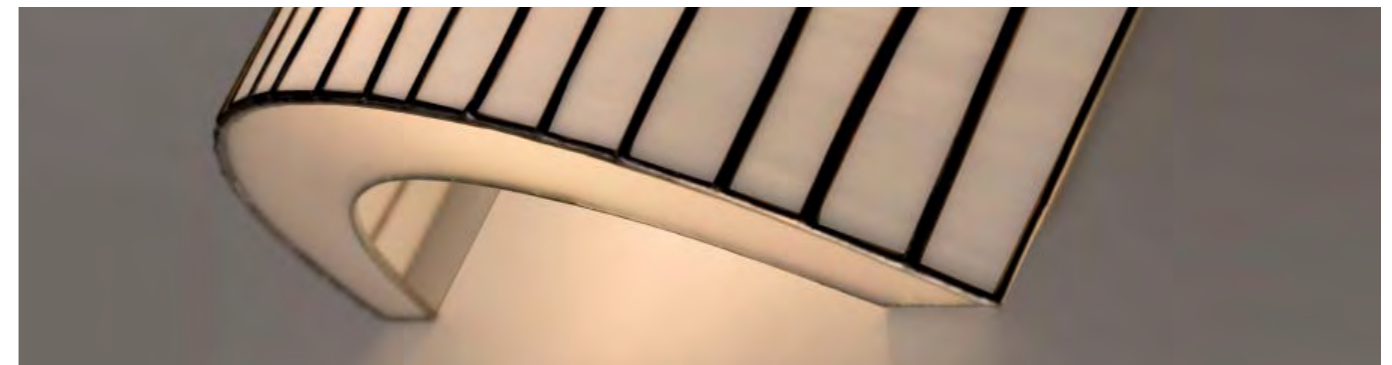

gilda

72

AÑO/YEAR
2006

MOSAICO DE VIDRIO: Arturo Álvarez utiliza un material para usos diferentes a la iluminación, como es el mosaico de vidrio italiano Bissaza™, el de mayor calidad y prestigio del mercado. En Gilda las piezas se unen a una estructura de hilos de acero dando como resultado una colección muy exclusiva.

GLASS MOSAIC: Arturo Álvarez uses raw materials with a different purpose, illumination, as he is doing with the mosaic of Italian glass, Bissaza™, the one of greatest quality and prestige in the market. In Gilda, the pieces are set together on a steel wired structure in order to obtain a very exclusive collection.

Glamour y sofisticación para aquellos que buscan decorar con singularidad. Una lámpara que dota de carácter los ambientes con una pieza altamente decorativa.

Glamour and sophistication for those who wish to decorate in a unique way. A lamp that lends character to spaces with a highly attractive piece.

arturo alvarez



gilda



↑ GD03NO (Ø35x60 | h:160 cm)

arturo alvarez



↑ GD01B (Ø18x40 | h:55 cm)

gilda

arturo alvarez



↑ **GD06-BB** (32x55x10 cm)



↑ **GD04NO** (Ø35x60 | h:200 cm)

↑ **GD04-1B** (Ø18x40 | h:150 cm)

VIDRIO ESTAÑADO: Arturo Álvarez reinventó la técnica tiffany, simplificando formas y colores, con un estilo único creó unos objetos contemporáneos muy simples. Las tulipas se hacen a partir de de las mejores opalinas de EEUU, que se cortan y se unen entre sí con estaño.

STAINED GLASS: Arturo Álvarez re-invented the Tiffany's lighting technique by simplifying forms and colours with his own style and created contemporary simple objects. The lamp shades are manufactured with the best US iridescent glasses, cut and soldered together.



GL06 (45x35x7 cm)



Una colección lúdica, divertida y alegre que nos remite a las formas y colores de los años setenta. Un conjunto de burbujas que aporta soluciones lumínicas muy variadas para uso doméstico y comercial.

A flashy, fun and cheerful collection that reminds us of the shapes and colours of the 70 's. A set of bubbles that provides diverse lighting solutions for both residential and commercial use.



↑ GL01 (30x35x8 | h:70 cm)



↑ GL05 (55x45x7 cm)



arturo alvarez
practica de
forma activa el
lado emocional,
sensible y
humano en todos
los ámbitos
de actuación
como empresa y
también ante la
sociedad

arturo alvarez
puts in practice
in an active form
the emotional,
sensitive and
human side in
every field of its
activities both in
the company and
in the society

arturo alvarez apuesta y hace realidad
la igualdad hombre mujer dentro de sus
instalaciones.

arturo alvarez goes for and makes real,
equality between man and woman in its
premises.

El total de su personal lo componen 45%
hombres y 55% mujeres.

Its staff is formed by 45% of men and
55% of women.

Desde sus comienzos ha incluido
personas con distintas minusvalías en su
plantilla con muy buenos resultados.

Since its creation, we have integrated
different disabled persons with real
success.

Cada vez está más presente entre
sus principales preocupaciones la
responsabilidad ante el planeta y el
medio ambiente. Aprovecha y recicla los
materiales y apuesta firmemente por el
bajo consumo.

The responsibility with the planet and the
environment are day by day one of our
core concerns. We use, re-use and recycle
materials and bet firmly for energy
saving policies.

Colabora desde hace tres años con una
ONG española y pretende aumentar y
continuar estas acciones en el resto del
mundo, los próximos años.

Since three years ago, it supports a
Spanish NGO: it actually pretends to
increase and continue these actions with
the rest of the world along the next years.

dos cubos

82

AÑO/YEAR
2000

VIDRIO ESTAÑADO: Arturo Álvarez reinventó la técnica tiffany, simplificando formas y colores, con un estilo único creó unos objetos contemporáneos muy simples. Las tulipas se hacen a partir de de las mejores opalinas de EEUU, que se cortan y se unen entre sí con estaño.

STAINED GLASS: Arturo Álvarez re-invented the Tiffany's lighting technique by simplifying forms and colours with his own style and created contemporary simple objects. The lamp shades are manufactured with the best US iridescent glasses, cut and soldered together.



D004-4 (100x10x12 | h:150 cm)

Una forma mínima, sencilla, trabajada con materiales de alta calidad que dan un resultado funcional, donde "menos es más". Una colección para decorar de una forma fresca y natural.

A minimal shape that is extremely simple, created with materials of high quality that yield a functional result where less is more. A collection to decorate with, in a fresh and natural way.

83

arturo alvarez



↑ D002 (25x8x12 | h:60 cm)



↑ D003 (28x12x14 | h:170 cm)

doscubos



↑ D001G (14x14x14 cm)



↑ D004-1 (12x12x10 | h:150 cm)



↑ D006G (14x14x14 cm)

cebra

86

AÑO/YEAR
2004

VIDRIO ESTAÑADO: Arturo Álvarez reinventó la técnica tiffany, simplificando formas y colores, con un estilo único creó unos objetos contemporáneos muy simples. Las tulipas se hacen a partir de de las mejores opalinas de EEUU, que se cortan y se unen entre sí con estaño.

STAINED GLASS: Arturo Álvarez re-invented the Tiffany's lighting technique by simplifying forms and colours with his own style and created contemporary simple objects. The lamp shades are manufactured with the best US iridescent glasses, cut and soldered together.



CE01 (15x15x15 | h:42 cm)

Formas sencillas y reconocibles. Pueden realizarse distintas combinaciones de opalinas, creando variaciones de la colección que se adaptan tanto a ambientes clásicos como contemporáneos.

Simple and recognizable shapes. Different combinations of iridescence can be made, thus creating variations on a collection that fits with both classical and contemporary environments.

87

arturo alvarez



↑ CE06 (36x21x7 cm)

sophi

88

AÑO/YEAR
2005

VIDRIO ESTAÑADO: Arturo Álvarez reinventó la técnica tiffany, simplificando formas y colores, con un estilo único creó unos objetos contemporáneos muy simples. Las tulipas se hacen a partir de de las mejores opalinas de EEUU, que se cortan y se unen entre sí con estaño.

STAINED GLASS: Arturo Álvarez re-invented the Tiffany's lighting technique by simplifying forms and colours with his own style and created contemporary simple objects. The lamp shades are manufactured with the best US iridescent glasses, cut and soldered together.



SP01 (30x14x7 | h:43 cm)

Dos curvas opuestas que se cierran hacia el interior recogiendo la luz para lanzarla hacia fuera. Una única y particular combinación de colores en la tulipa que se conjugan de forma singular.

Two opposite curves that close towards the interior, gathering up light and throwing it outwards. A special and unique combination of colours in a shade joined in a peculiar way.

89

arturo alvarez



↑ SP04 (45x21x10 | h:90 cm)

sophi



↑ SP04-1 (30x14x7 | h:150 cm)

arturo alvarez



↑ SP06 (45x19x12 cm)

encaixe

92

AÑO/YEAR
2002

VIDRIO ESTAÑADO: Arturo Álvarez reinventó la técnica tiffany, simplificando formas y colores, con un estilo único creó unos objetos contemporáneos muy simples. Las tulipas se hacen a partir de de las mejores opalinas de EEUU, que se cortan y se unen entre sí con estaño.

STAINED GLASS: Arturo Álvarez re-invented the Tiffany's lighting technique by simplifying forms and colours with his own style and created contemporary simple objects. The lamp shades are manufactured with the best US iridescent glasses, cut and soldered together.

Un juego de volúmenes, un equilibrio de formas, una forma estable en tensión. Tres piezas que unidas crean un solo volumen de forma caprichosa. Una colección lúdica y armónica.

A set of volumes, a balance of shapes, a stable form of tension. Three pieces that, united, create a single volume in a whimsical manner. A lucid and harmonious collection.

arturo alvarez

93



encaixe



↑ EN01 (17x12x17 | h:40 cm)

arturo alvarez

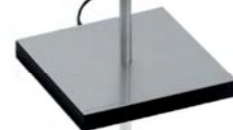

↑ EN03 (26x18x26 | h:152 cm)

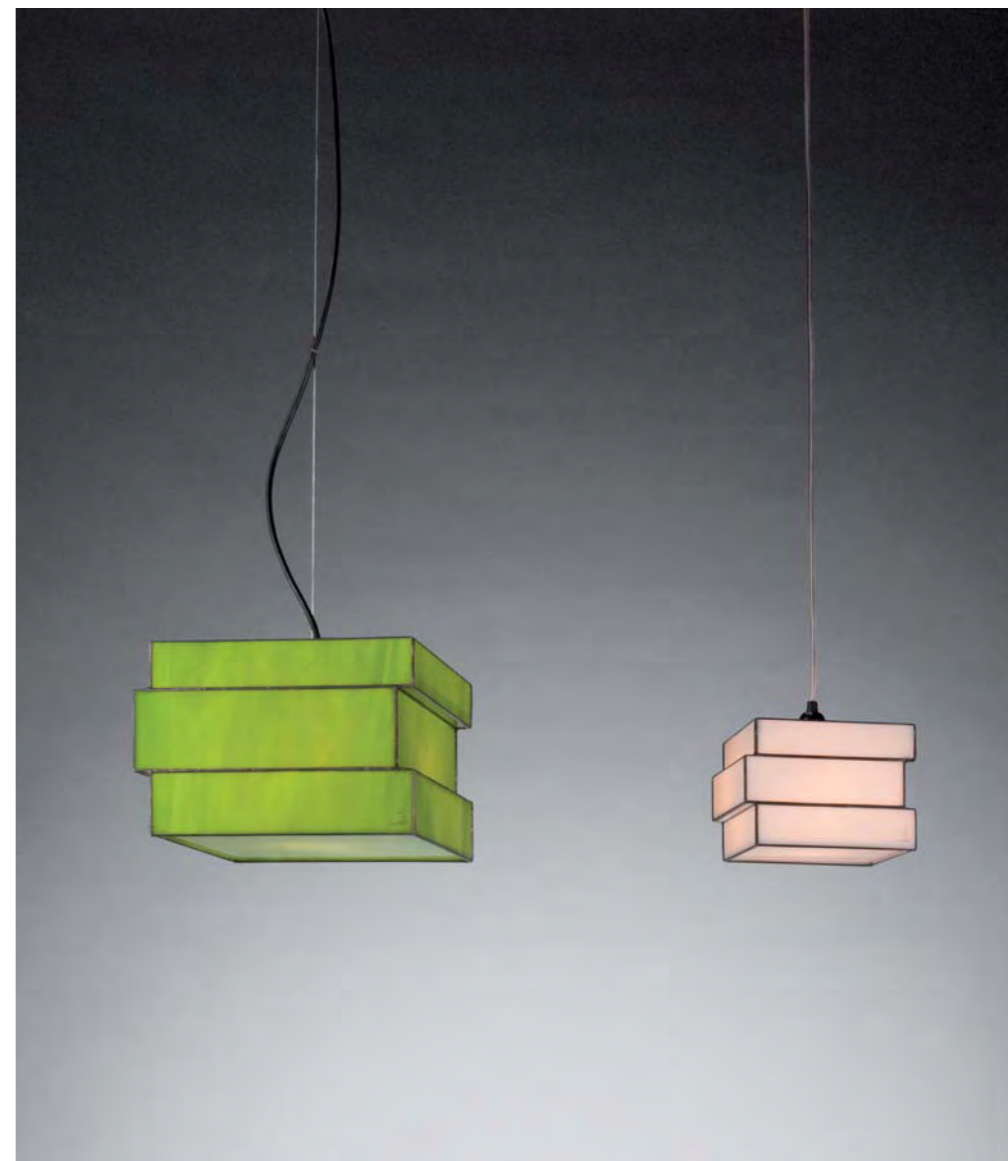

↑ EN04 (26x18x26 | h:90 cm)

↑ EN04-1 (17x12x17 | h:150 cm)

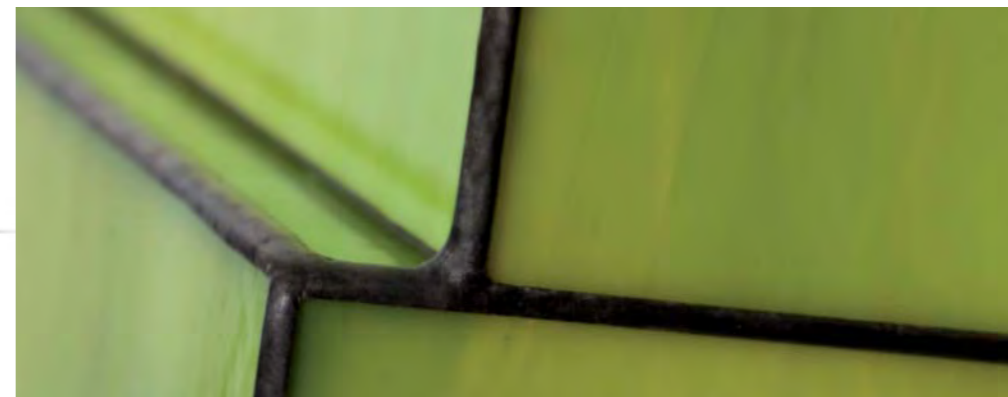

domino

96

AÑO/YEAR
2002

VIDRIO ESTAÑADO: Arturo Álvarez reinventó la técnica tiffany, simplificando formas y colores, con un estilo único creó unos objetos contemporáneos muy simples. Las tulipas se hacen a partir de de las mejores opalinas de EEUU, que se cortan y se unen entre sí con estaño.

STAINED GLASS: Arturo Álvarez re-invented the Tiffany's lighting technique by simplifying forms and colours with his own style and created contemporary simple objects. The lamp shades are manufactured with the best US iridescent glasses, cut and soldered together.



DM01 (18x11x18 | h:39 cm)

Una forma sencilla realizada con la particular colocación de los cuadrados de vidrio estañado de color en la pantalla. Originalidad dentro de la sencillez de formas.

A simple shape enhanced with the specific placement of glass squares stained with colour on the diffuser. Originality within simplicity of shapes.

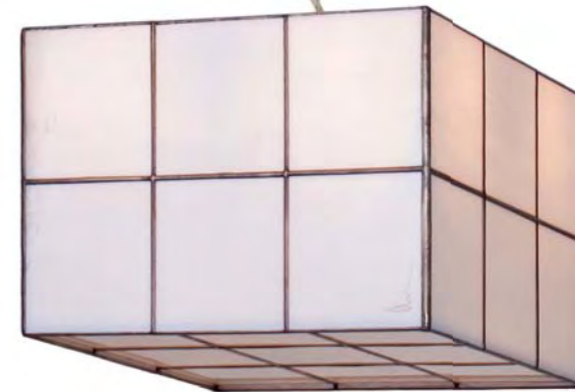

↑ DM04 (31x20x31 | h:90 cm)

97

arturo alvarez

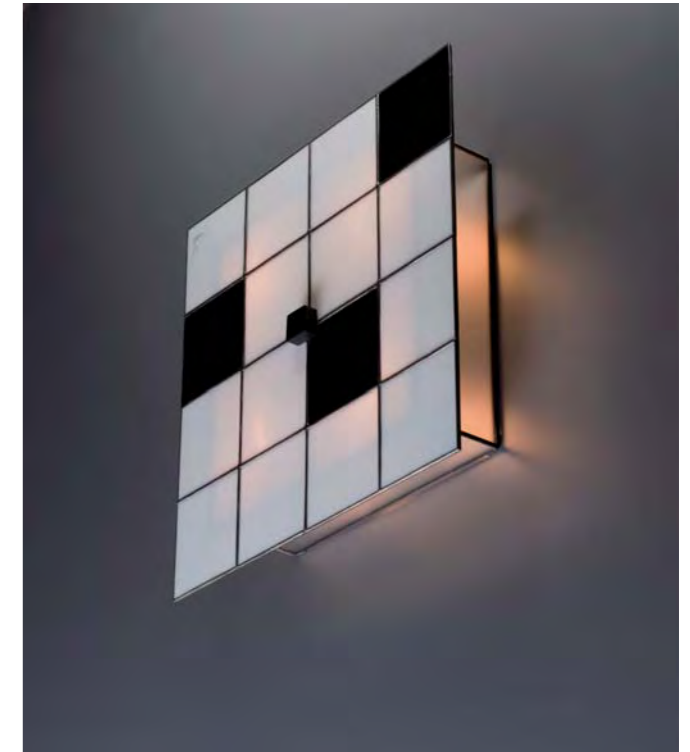

↑ DM05 (36x36x9 cm)

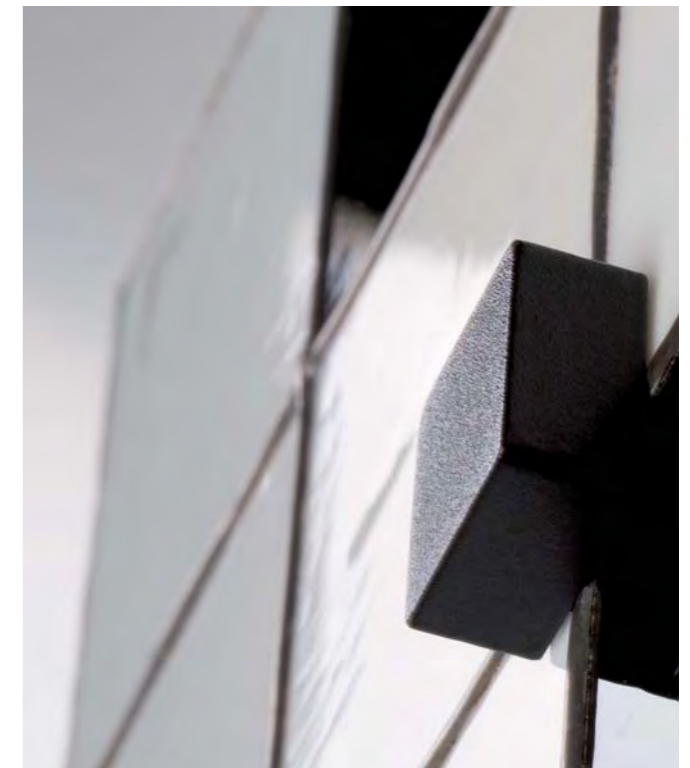

↑ DETALLE DM05 / DM05 DETAIL

greta

VIDRIO ESTAÑADO: Arturo Álvarez reinventó la técnica Tiffany, simplificando formas y colores, con un estilo único creó unos objetos contemporáneos muy simples. Las tulipas se hacen a partir de de las mejores opalinas de EEUU, que se cortan y se unen entre sí con estaño.

STAINED GLASS: Arturo Álvarez re-invented the Tiffany's lighting technique by simplifying forms and colours with his own style and created contemporary simple objects. The lamp shades are manufactured with the best US iridescent glasses, cut and soldered together.



GR06 (13x26x10 cm)

Líneas rectas que se abren a suaves curvas. Una colección que nos remite al romanticismo y al misterio oriental, en la que la delicadeza y armonía de formas se convierten en su sello particular.

Straight lines that open up into soft curves. A collection that reminds us of romanticism and oriental mystery, where delicacy and harmony of form are signature features.



↑ GR01 (13x26x13 | h:52 cm)

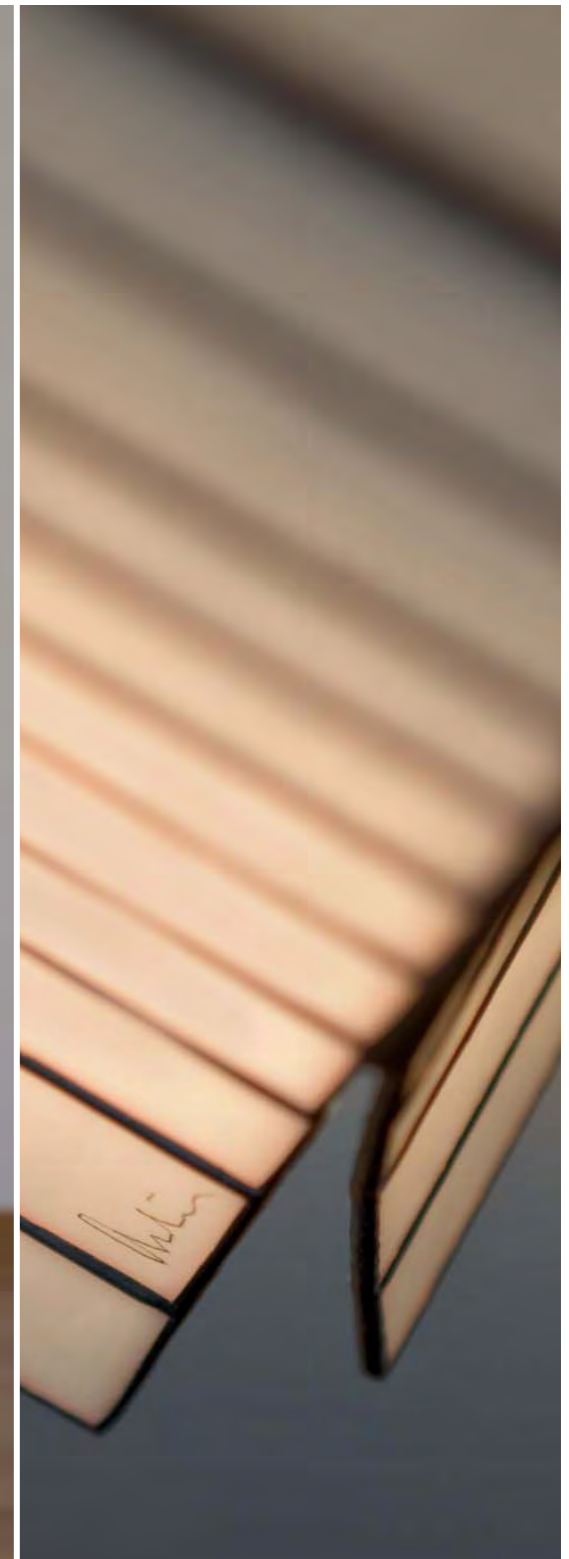

↑ DETALLE TULIPA / LAMPSHADE DETAIL



Crear, emocionar,
sorprender,
ilusionar,
nuestra razón
de ser y premisa
fundamental
para los próximos
años

Create, excite,
surprise, thrill,
our raison d'être
and our basic
premise for the
coming years

Seguimos trabajando con el entusiasmo
de siempre buscando mayor innovación,
mayores prestaciones de los diseños
y nuevas tecnologías para el ahorro
energético.

We keep on working with the same
old enthusiasm and searching major
innovations, more features in our designs
and new energy-saving technologies.

Una característica diferencial de la
marca es que podemos crear "lámparas a
la carta", con múltiples posibilidades de
materiales y composiciones posibles.

One distinguishing characteristic of
our brand is that we can create "tailor-
made lamps" with lots of possibilities in
materials and combinations.

El ser humano con sus necesidades e
intereses en sus distintas situaciones
vitales es el centro de nuestro proyecto.
Trabajamos para provocar emociones
positivas. Que nuestras luces en los
espacios creen armonía y equilibrio, una
"luz emocional" que contribuya a un mayor
bienestar y confort.

The human being with all its needs and
interests in any moment in life is the
core of our project. We work to tempt you
with positive emotions. Our lights create
harmony and balance in every space, an
"emotional light", contributing to a greater
well-being and comfort.

kono

102

AÑO/YEAR
2004

VIDRIO ESTAÑADO: Arturo Álvarez reinventó la técnica tiffany, simplificando formas y colores, con un estilo único creó unos objetos contemporáneos muy simples. Las tulipas se hacen a partir de de las mejores opalinas de EEUU, que se cortan y se unen entre sí con estaño.

STAINED GLASS: Arturo Álvarez re-invented the Tiffany's lighting technique by simplifying forms and colours with his own style and created contemporary simple objects. The lamp shades are manufactured with the best US iridescent glasses, cut and soldered together.



KN04G (15x90x15 | h:250 cm)

KN04-1 (10x50x10 | h:150 cm)

Una forma contundente y enérgica que se eleva creando un volumen dinámico en el que la luz se difumina y se tamiza. Claroscuros que suavizan su altura, convirtiéndola en una figura bella y esbelta.

A forceful and energetic shape that rises up and creates a dynamic volume where light is dispersed and shaded. Chiaroscuro that softens its height and makes it a lovely, willowy figure.

103

arturo alvarez

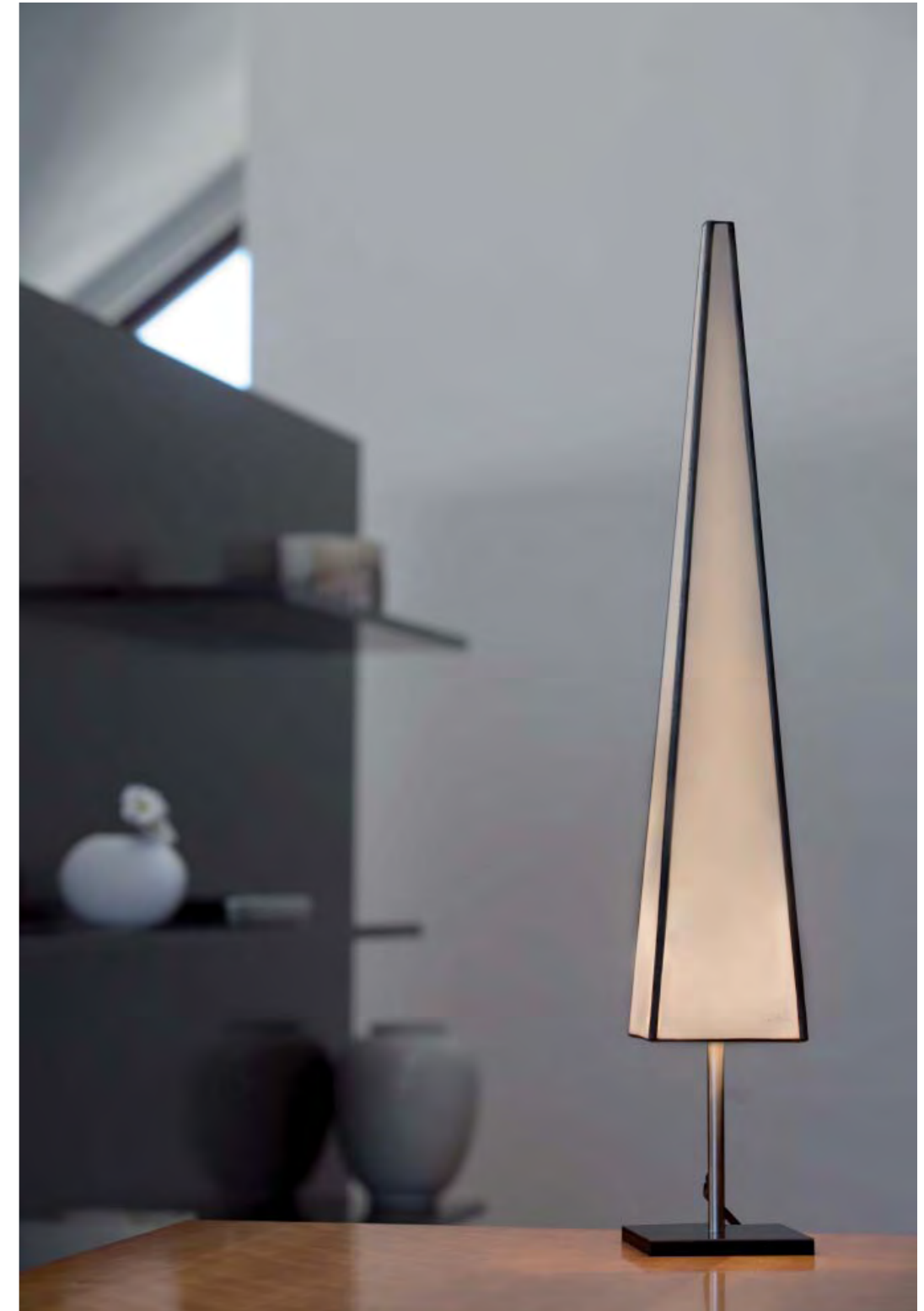

↑ KN01 (10x50x10 | h:63 cm)

senda

104

AÑO/YEAR
2003

VIDRIO ESTAÑADO: Arturo Álvarez reinventó la técnica tiffany, simplificando formas y colores, con un estilo único creó unos objetos contemporáneos muy simples. Las tulipas se hacen a partir de de las mejores opalinas de EEUU, que se cortan y se unen entre sí con estaño.

STAINED GLASS: Arturo Álvarez re-invented the Tiffany's lighting technique by simplifying forms and colours with his own style and created contemporary simple objects. The lamp shades are manufactured with the best US iridescent glasses, cut and soldered together.



SN01 (13x14x13 | h:38 cm)

SN02 (18x20x18 | h:55 cm)

105

Una forma sencilla que se abre hacia arriba y hacia abajo mediante una suave curva. Una lámpara que abraza el ambiente, que lo ilumina repartiendo la luz de forma equilibrada y tranquila.

A simple shape that opens upwards and downwards with a smooth curve. A lamp that embraces its surroundings, illuminating them with a balanced and peaceful light.



↑ SN04-1 (13x14x13 | h:150 cm)

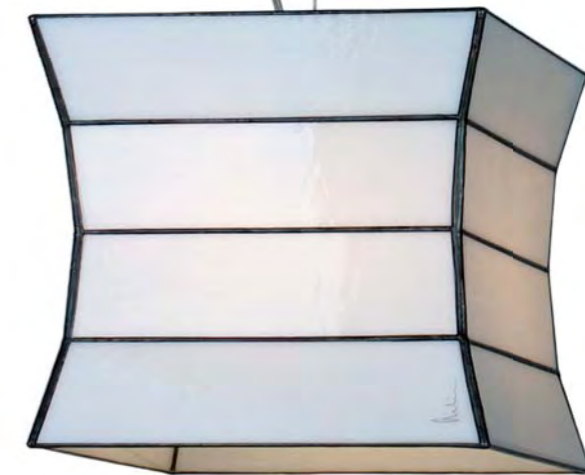

↑ SN04 (25x24x25 | h:90 cm)

arturo alvarez

sombras

106

AÑO/YEAR
2003

VIDRIO ESTANADO: Arturo Álvarez reinventó la técnica tiffany, simplificando formas y colores, con un estilo único creó unos objetos contemporáneos muy simples. Las tulipas se hacen a partir de de las mejores opalinas de EEUU, que se cortan y se unen entre sí con estaño.

STAINED GLASS: Arturo Álvarez re-invented the Tiffany's lighting technique by simplifying forms and colours with his own style and created contemporary simple objects. The lamp shades are manufactured with the best US iridescent glasses, cut and soldered together.



S006 (15x30x8)

107

arturo alvarez

Un juego de claroscuro, de luz y de sombra, que busca el equilibrio y la sobriedad de los ambientes que ilumina.

A set of chiaroscuro, light and shadow that seeks the balance and sobriety of the spaces it illuminates.

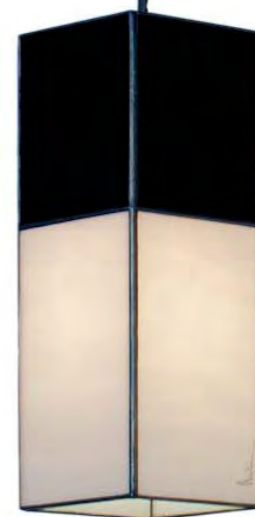

↑ S004-1 (10x27x10 | h:150 cm)

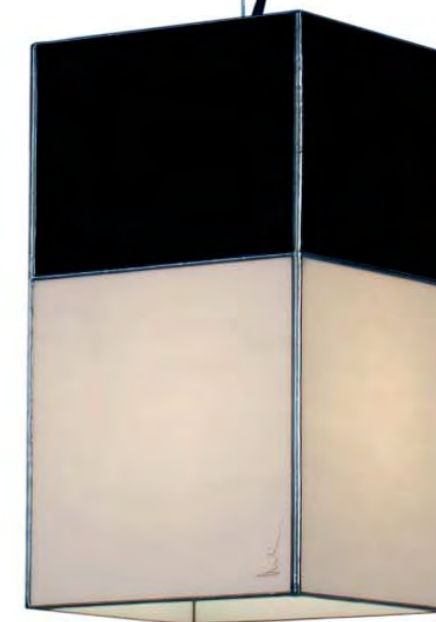

↑ S004 (17x31x17 | h:90 cm)

apliques plafones

wall lamps ceiling lamps

VIDRIO ESTAÑADO: Arturo Álvarez reinventó la técnica tiffany, simplificando formas y colores, con un estilo único creó unos objetos contemporáneos muy simples. Las tulipas se hacen a partir de de las mejores opalinas de EEUU, que se cortan y se unen entre sí con estaño.

STAINED GLASS: Arturo Álvarez re-invented the Tiffany's lighting technique by simplifying forms and colours with his own style and created contemporary simple objects. The lamp shades are manufactured with the best US iridescent glasses, cut and soldered together.



A0501 (44x31x10 cm)



Apliques y plafones funcionales y prácticos realizados con distintas técnicas, cuyas formas se adaptan a usos en el hogar y en instalaciones comerciales.

Useful and practical wall sconces made with different techniques and whose shapes adapt to both residential and commercial applications.

arturo alvarez

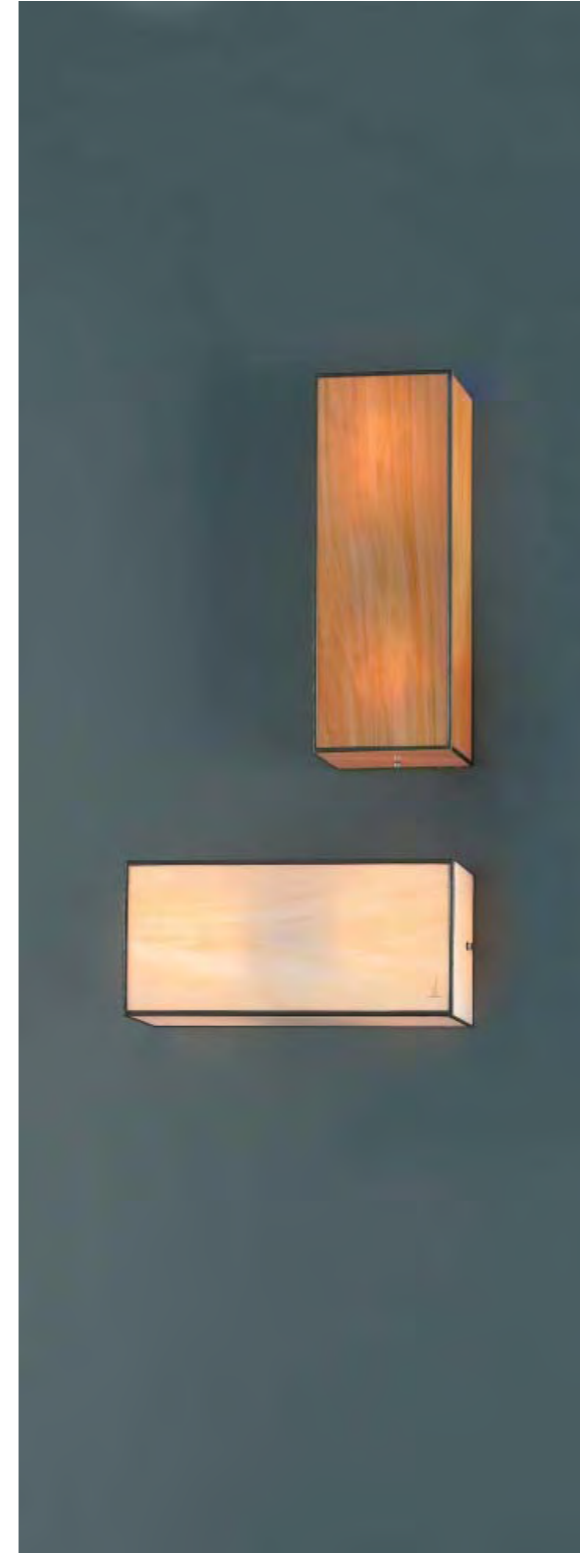

↑ A0604 (38x15x9 cm)



↑ SL06 (75x75x12 cm)



↑ DETALLE ACERO / STEEL DETAIL

exterior

110

AÑO/YEAR
2004

VIDRIO ESTAÑADO: Arturo Álvarez reinventó la técnica tiffany, simplificando formas y colores, con un estilo único creó unos objetos contemporáneos muy simples. Las tulipas se hacen a partir de de las mejores opalinas de EEUU, que se cortan y se unen entre sí con estaño.

STAINED GLASS: Arturo Álvarez re-invented the Tiffany's lighting technique by simplifying forms and colours with his own style and created contemporary simple objects. The lamp shades are manufactured with the best US iridescent glasses, cut and soldered together.



EXCE06 (50x11x6 cm)



Tres modelos diferentes trabajados a través de la calidez de las opalinas para decorar tanto de día como de noche. En Cebra y Sombras las formas rectas marcan la línea, una en blancos y la otra en blanco y negro. Cup, de formas curvas está producida en blanco. Tres opciones diferentes con una misma personalidad.

Three different models wrought through the warmth of the opalines to decorate both by day and by night. In Cebra and Sombras the straight shapes mark a line, one in white and the other in black and white. Cup, with curved forms its made in white. Three different options, one personality.

111

arturo alvarez



↑ EXS006 (6x45x6 cm)



↑ EXCU06 (14x43x10 cm)

ventopop

Edición exclusiva y limitada Limited and exclusive edition

112

AÑO/YEAR
2009

Arturo Álvarez se propone hacer un homenaje al Arte Pop. Esta colección está inspirada en la rebeldía de este movimiento, remover materiales y colores de su contexto habitual para construir otros diferentes que sorprendan.

Arturo Álvarez intends to honour pop art. This collection is inspired in a time of rebellious movements, the defiance to remove materials from its usual context and to construct other different which can surprise

113



VIDRIO ADHERIDO: Aprovechando la belleza de las opalinas y con ánimo de ofrecer diseños más delicados y sutiles, suprimiendo la soldadura de estaño, surge la idea de utilizar la técnica de vidrio pegado, cuyas piezas se colocan adhiriéndolas a una estructura de metacrilato.

STICKED GLASS: By eliminating the solder, making the most of the beauty of glass and with the aim of offering more sensitive and subtle designs, arose the idea of using the technique of glued glass. These pieces are fixed on a methacrylate structure.

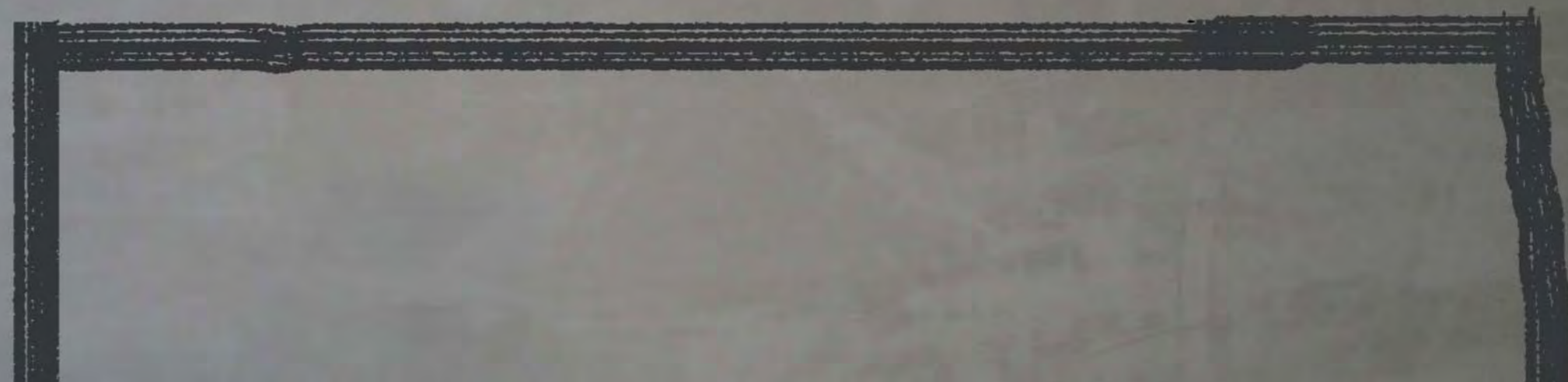

ventopop



↑ VN01POP (58x19x8 cm)

↓ VN01POP DETALLE / VN01POP DETAIL



↑ VN04POP (95x17x10 | h:150 cm)

↓ VN04POP DETALLE / VN04POP DETAIL



arturo alvarez

emo
tional
light



Lab
arturo alvarez

Nace LAB arturo alvarez, un laboratorio de ideas abierto a los diseñadores

LAB arturo alvarez is created, a laboratory of ideas open to designers

En el año 2008, empujados por nuestra inquietud y constante búsqueda de la innovación, creamos LAB arturo alvarez, un marco nuevo, un laboratorio de ideas para dar cabida a la sensibilidad de otros diseñadores y también del propio Arturo Álvarez, conjugando el ingenio, la innovación y la experimentación técnica y formal con el estilo propio de nuestra empresa.

In 2008, driven by our own motivation and constant search for innovation, we created LAB arturo alvarez, a new setting, a laboratory of ideas to make room for the sensibilities of other designers in addition to Arturo Álvarez himself. Combining ingenuity, innovation and technical and formal experimentation with the style of our company.

Queremos dar cabida al intercambio entre distintos profesionales, hablando, haciendo, disfrutando y dando rienda suelta a sus visiones sobre hacia dónde debe ir y como debe ser la iluminación decorativa y comercial actual. Es por esta razón por la que nace LAB, una nueva línea de arturo alvarez para ofrecer nuevas posibilidades a nuestros clientes.

We seek to create a space for different professionals to exchange ideas, talk, create and enjoy. Giving a free hand to their ideas about where decorative and commercial lighting should go and what it must be. This is the purpose of LAB, a new line of arturo alvarez, to offer our customers new possibilities.

AÑO/YEAR
2010

Tiras de polipropileno se trabajan de distintas maneras para lograr formas con volumen y gracia aportando unos diseños muy frescos y ligeros que tamizan la luz de forma cálida.

Strips of polypropylene molded in different ways to obtain large forms with volume and graceful. Very fresh and light designs which filter the light in a warm way.



↑ AR04 (Ø60x20 | h:150 cm)

ARTURO ÁLVAREZ AROS



Los cuerpos celestes girando una y otra vez y nosotros con ellos, en una danza sin fin, sin tiempo, llena de armonía. La luz, caprichosa, se escapa por los espacios abiertos.

The heavenly bodies spinning around, time and again so we with them, in an endless dance, timeless, full of harmony. The light, fussy, escapes between the open spaces.



AROS
ARTURO
ÁLVAREZ

120

Lab



↑ AR04 (Ø60x20 | h:150 cm)



↑ AR03 (Ø60x20 | h:160 cm)

↑ AR03G (Ø60x20 | h:188 cm)



↑ AR03 (Ø60x20 | h:160 cm)

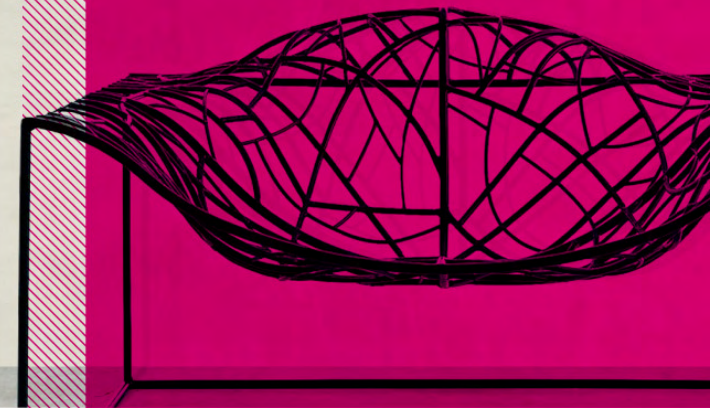



2009

A partir de una malla de acero electrosoldada reciclable y plana se consiguió un diseño contundente, traslúcido y sutil, que a través de sus pliegues se llena de volumen y emoción.

From a stainless, electro-welded, recyclable and plain steel mesh, we obtained a forceful design, translucent and subtle ready to offer volume and emotion through its pleats.



↑ FL04 (Ø80x70 | h:200 cm)

AÑO/YEAR
2009

ARTURO ÁLVAREZ FLUO



Ver o no ver, estar de forma sutil y mágica. Transparencias y volúmenes danzan juntos entrelazándose en un abrazo único e infinito. Un dejarse llevar, intuir y soñar.

To see or not to see, to be in a gentle and magical form. Transparency and volume dancing together intertwining in a unique and endless hug. Floating, sensing and dreaming.





↑ FL04 (Ø80x70 | h:200 cm)

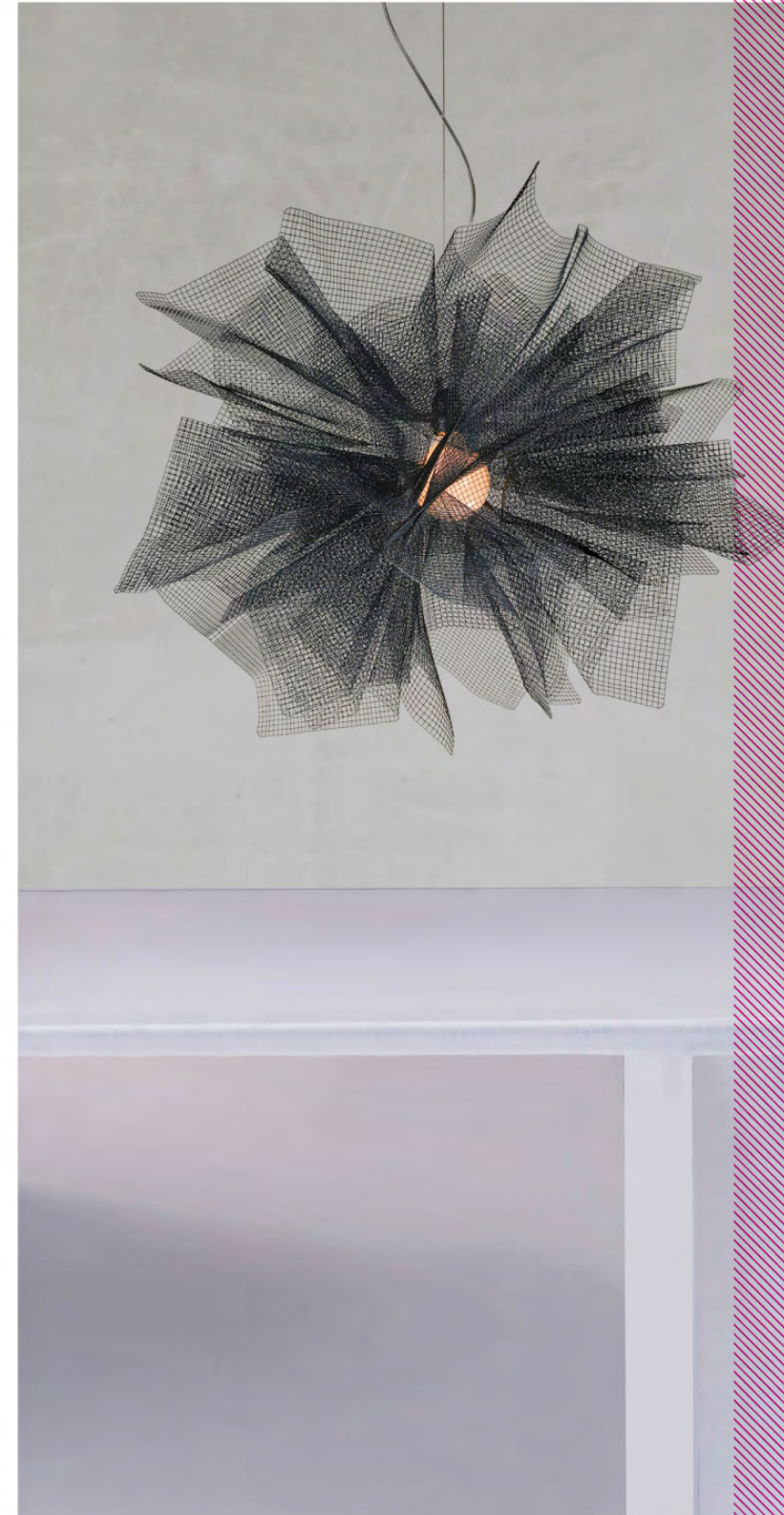

↑ FL04 (Ø80x70 | h:200 cm)



FLUO
ARTURO
ÁLVAREZ

128

Lab

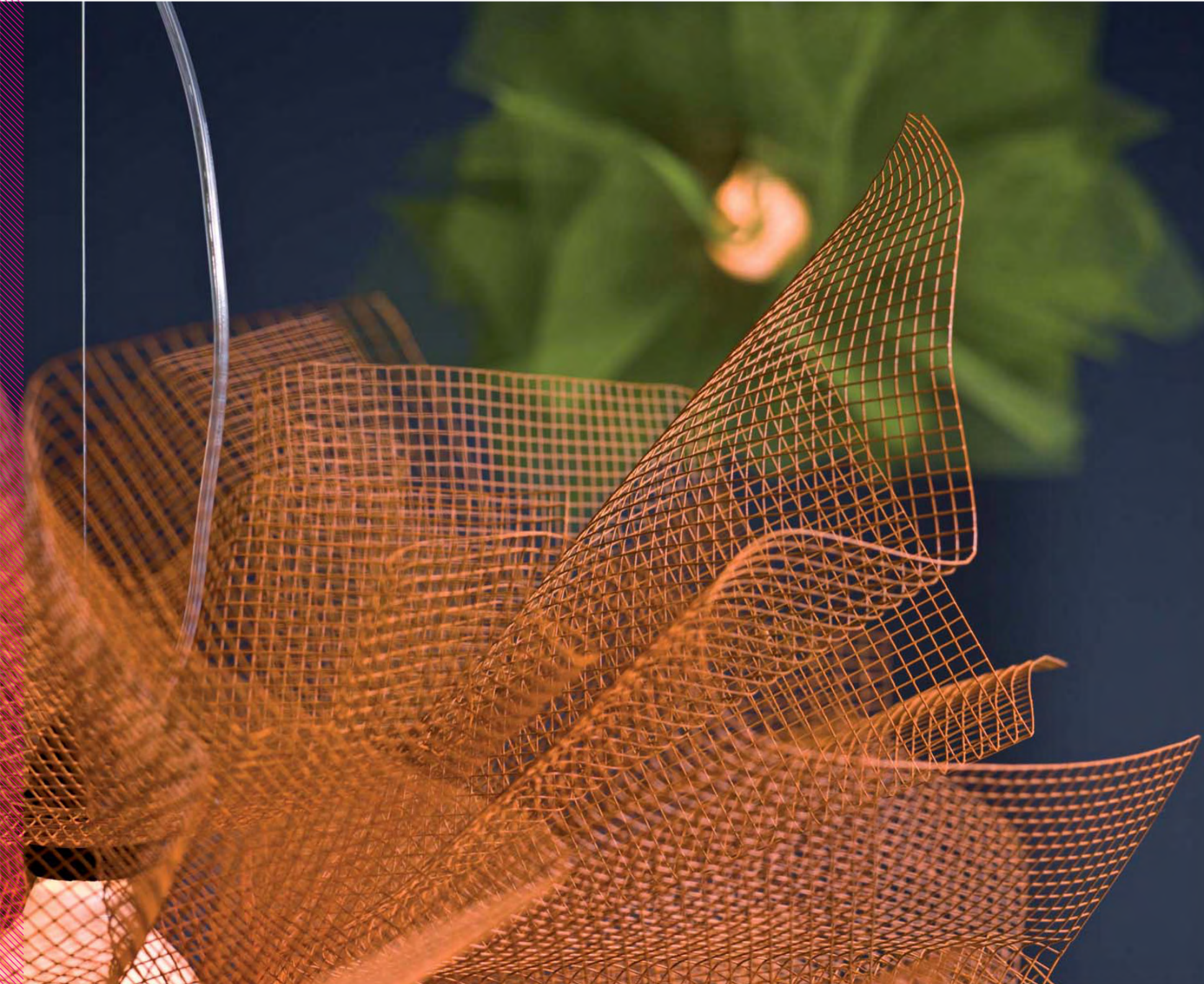

↑ FL04 (Ø80x70 | h:200 cm)



reddot design award
winner 2010

AÑO/YEAR
2008



Todo sencillez, dos discos de metal tratado y pintado con un juego de rótula y piezas metálicas que permiten abatimientos y rotaciones que confieren gran funcionalidad a la pieza.

Full of simplicity, two treated and painted metal disks with a knuckle joint and metal pieces which allow rotations and up and downs so to give larger versatility to the piece.



↑ GU06 (Ø45x9 cm)

EL ÚLTIMO GRITO GUAU

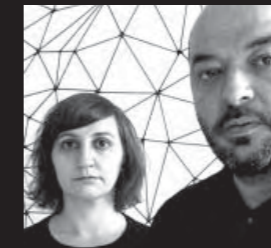

Rosario Hurtado
& Roberto Feo

La fascinación de los claroscuros; la luz que juega con el observador, que encandila, que se mueve, que gira y que crea un magnetismo lleno de magia a su alrededor.

The fascination of the chiaroscuro, light that plays with the observer, charming them, moving, spinning and creating magnetism full of magic all around.



GUAU EL ÚLTIMO GRITO

132

Lab



↑ GU06 (Ø45x9 cm)

↑ GU06P (Ø30x9 cm)

↑ GU06 (Ø45x9 cm)



GUAU EL ÚLTIMO GRITO

134



DETALLE APERTURA / OPENING DETAILS

135

Lab



DETALLE POSICIONES / POSITION DETAILS

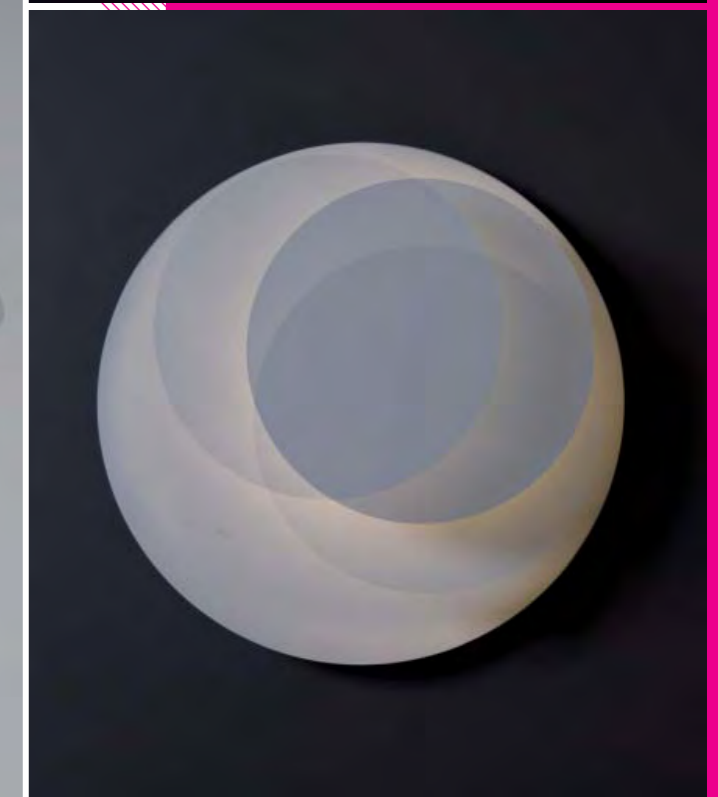
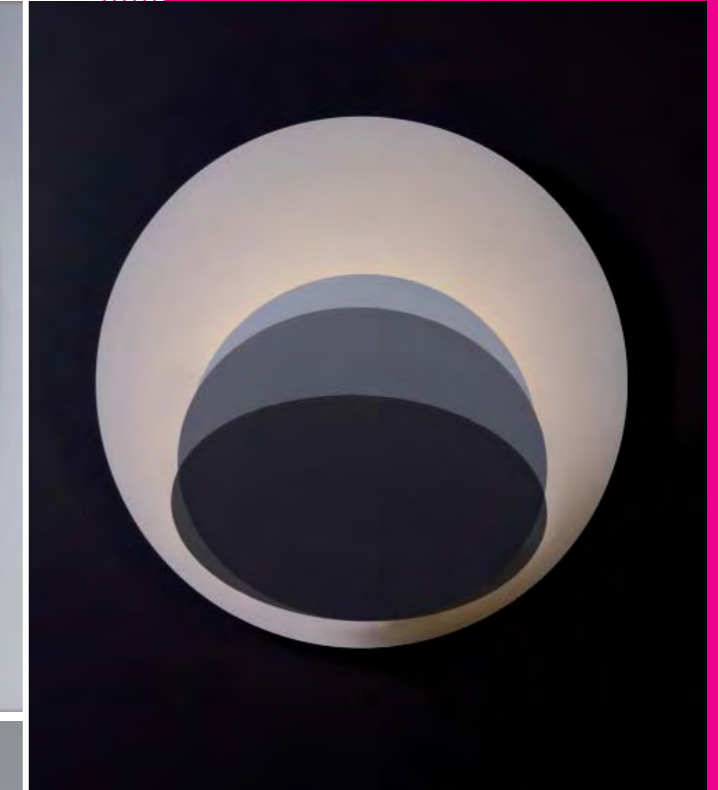

AÑO/YEAR
2007

A través de la tecnología de inyección de plástico se consigue una familia de luminarias que a través de sus lamas, combinadas de forma geométrica, nos sumergen en un mundo onírico.

With the help of the plastic injection technology we developed a lighting collection which, through its ribs combined with the geometrical form, immerses us in a world of dreams.



↑ **VV04G** (Ø105x29 | h:200 cm)

↑ **VV04** (Ø80x29 | h:150 cm)

HÉCTOR SERRANO V



Una forma espacial, pero cercana y posible, que nos emociona y con la que nos identificamos, a través de lo extraordinario y fantástico.

A shape that is spatial, yet near and tangible, that thrills and inspires a sense of identity through the extraordinary and fantastic.





↑ VV03 (Ø80x29 | h:173 cm)





↑ VV04 (Ø80x29 | h:150 cm)



↑ VV03 (Ø80x29 | h:173 cm)

AÑO/YEAR
2004

Tiras de polipropileno se trabajan de distintas maneras para lograr formas con volumen y gracia aportando unos diseños muy frescos y ligeros que tamizan la luz de forma cálida.

Strips of polypropylene molded in different ways to obtain large forms with volume and graceful. Very fresh and light designs which filter the light in a warm way.



↑ BE03 (Ø65x55 | h:185 cm)

ARTURO ÁLVAREZ BETY



Fetichismo, sofisticación, la femineidad recreada, una forma inacabada, libre. Un objeto con historia, con memoria, que aporta una nueva narrativa.

Fetishism, sophistication, re-created femininity, an unfinished shape, free. An object with history and memory, which contributes a new narrative.





↑ BE03 (Ø65x55 | h:185 cm)



↑ BE01 (Ø35x35 | h:70 cm)



↑ BE04 (Ø65x55 | h:150 cm)

↑ BE04-1 (Ø35x35 | h:150 cm)



AÑO/YEAR
2008

La técnica utilizada es el moldeo rotacional una innovación tecnológica a la que se ha buscado dotar de alma, funcionalidad y belleza. De tacto suave se vuelve cercana y llena de emoción.

The technique used is the slush moulding, an innovative technology which has been provided with soul, versatility and beauty. With a gentle touch, it turns closer and full of emotion.



↑ LU01 (Ø40x50 cm)

MARTÍN AZÚA LUA



La luna en la tierra. Podemos tocarla, abrazarla, jugar con ella y transportarla. Atrapar a través de los sentidos parte de su encanto y misterio.

The moon on the Earth. We can touch it, embrace it, play with it and transport it. We can grasp with our senses part of its charm and mystery.





↑ LU01 (Ø40x50 cm)

PARA INTERIOR Y EXTERIOR / IN & OUT USE





↑ LU04 (Ø40x60 | h:150cm)



↑ LU01 (Ø40x50 cm)

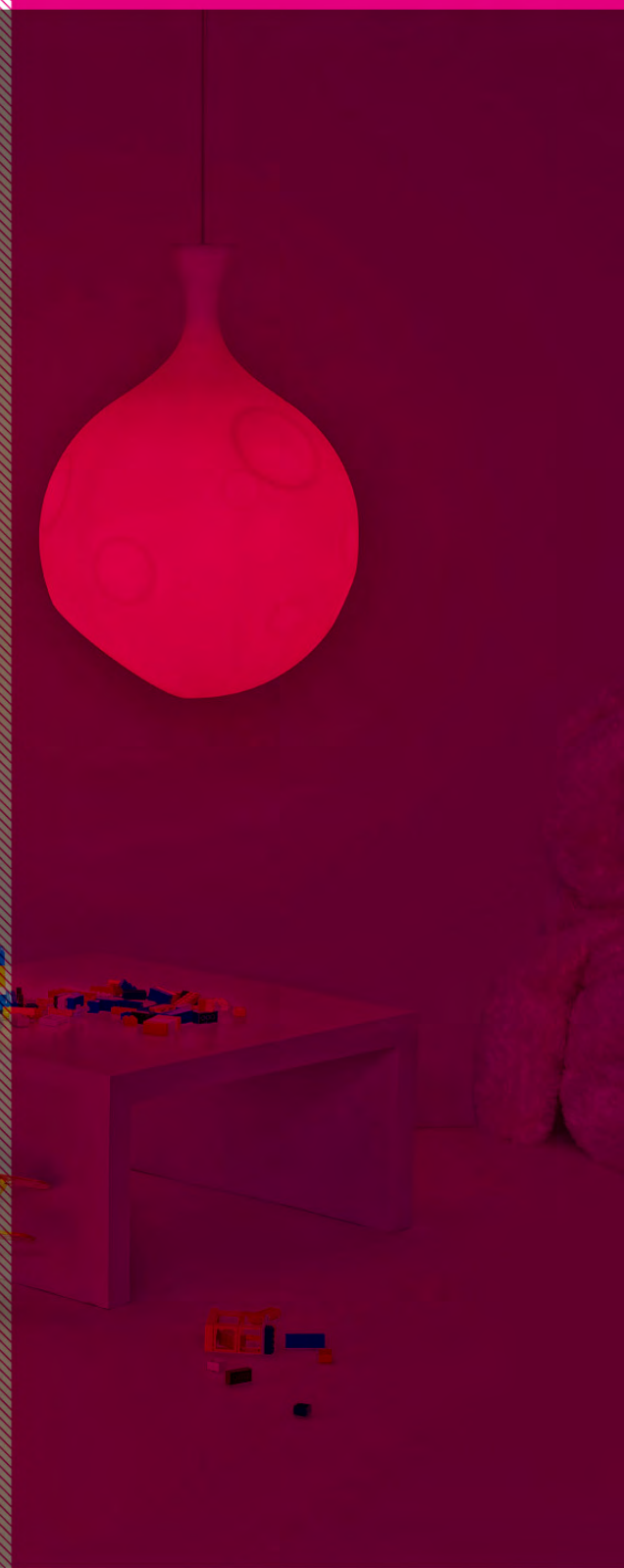

AÑO/YEAR
2008

Después de dos años de investigación nace un nuevo material de la combinación de malla metálica con silicona: flexible, lavable, moldeable permite conseguir volúmenes increíbles.

After two years of research we obtained a new material from the combination of metallic mesh and silicone: pliable, washable, malleable so it allows to obtain amazing volumes.

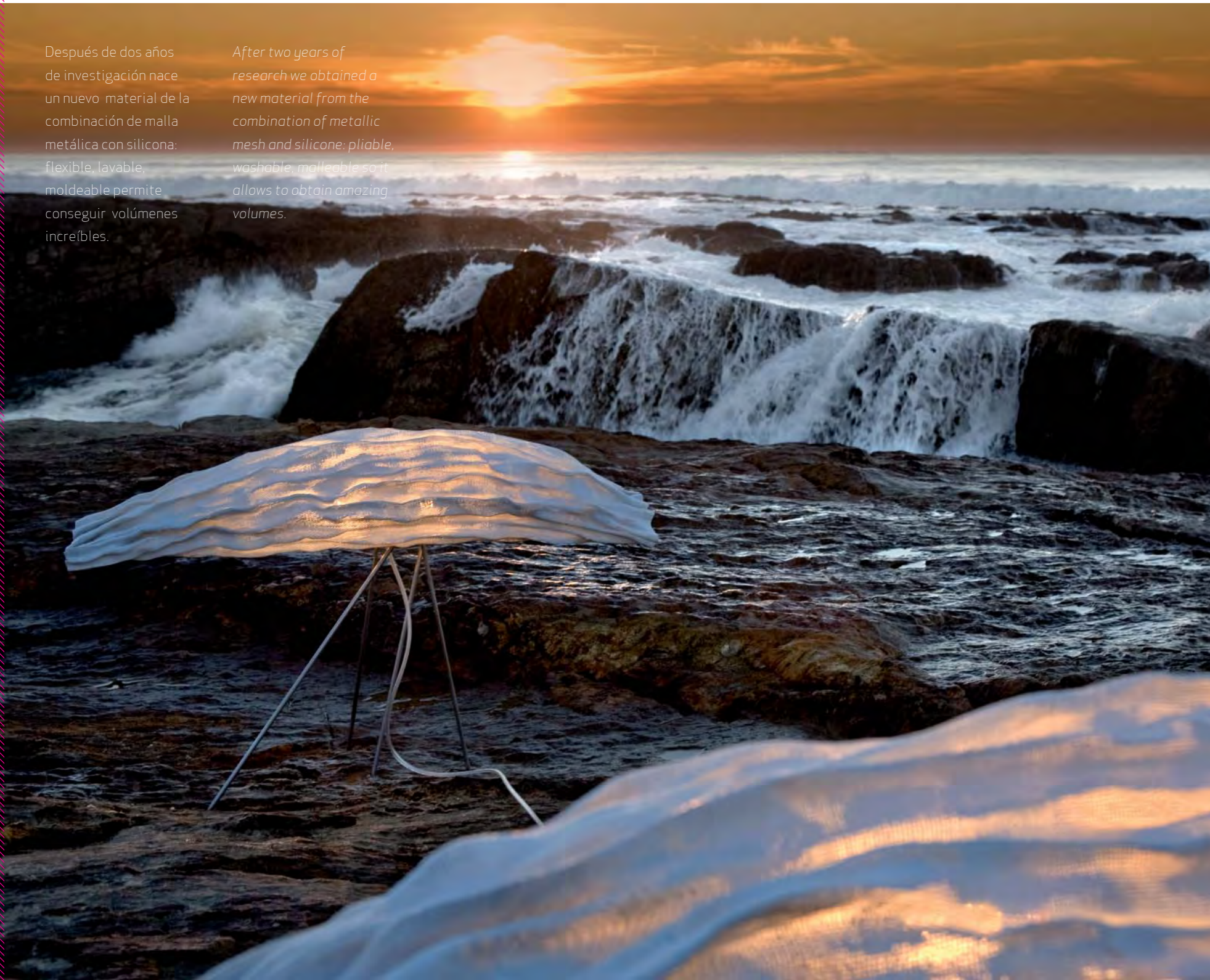

↑ IK01 (80x16x25 | h:50 cm)

ARTURO ÁLVAREZ IKI



Envolvente, suave y lúdica. Un ser orgánico, vivo, amable, que invita a ser tocado y observado. Su interior misterioso y oculto por momentos es traslúcido y brillante.

Enveloping, soft and fun. An organic, living, and kind being that invites you to touch and observe it. Its dark and mysterious interior at times is transparent and bright.





↑ IK04 (120x20x30 | h:150 cm)



↑ IK01 (80x16x25 | h:50 cm)



↑ IK04 (120x20x30 | h:150 cm)



Lab

contract

Trabajamos para dar soluciones lumínicas decorativas únicas y originales. Para entornos públicos o privados con muy diferentes estilos decorativos. Iluminamos los espacios aportando novedad y elegancia, potenciando o matizando el peso de focos y empotrables.

Personalizamos y adaptamos los diseños de catálogo y realizamos modelos especiales para ofrecer un toque personal, diferenciado y único a cada uno de los proyectos.

We work in order to provide with unique and original decorative lighting solutions to anyone, both for public and private environments with pretty different decorative styles. We illuminate spaces with newness and elegance, boosting or toning down the influence of spots and semi-recessed lamps.

We customize and adapt all the designs of our catalogue and develop special models to offer a personal touch, different and unique to every project

arturo alvarez

contract

arturo alvarez

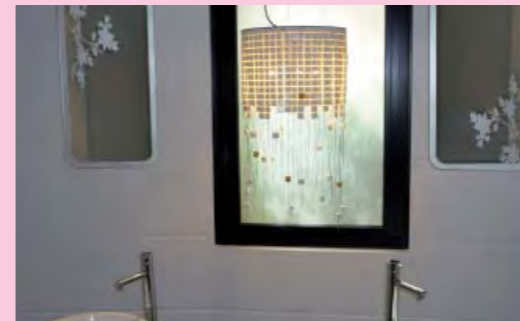
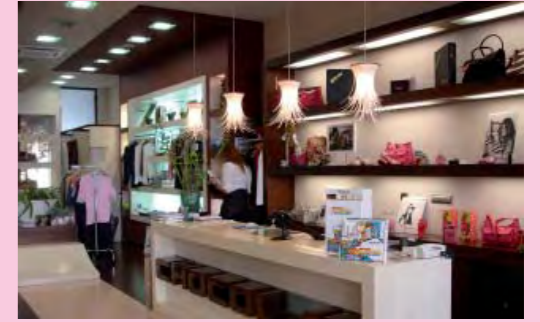
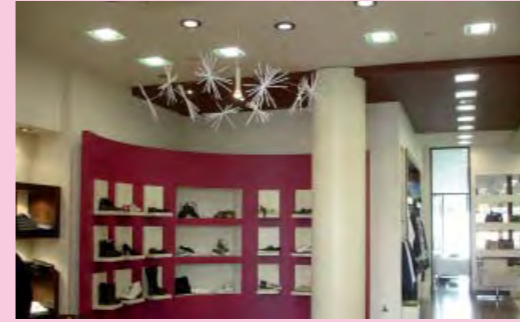
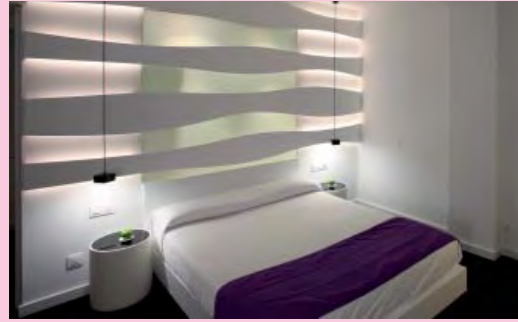



directorio
técnico

technical
directory

arturo alvarez

directorio
acabados
vidrio

directory
glass
finishes

166

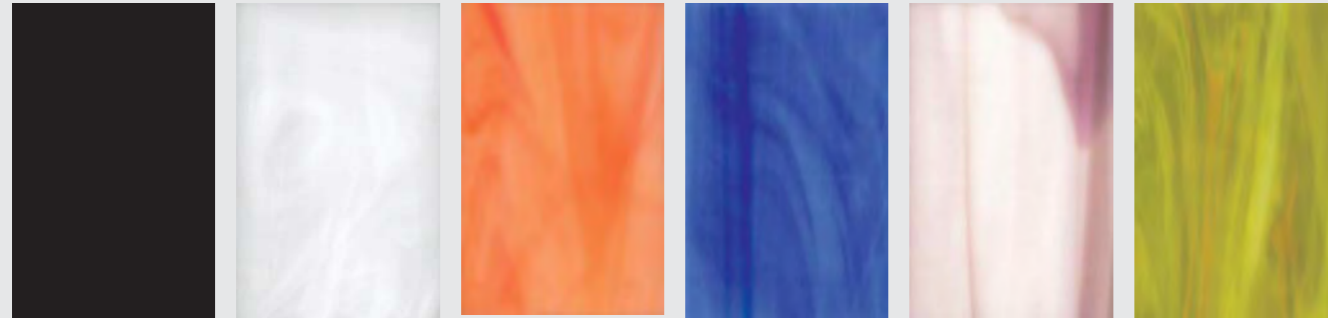

01 NEGRO BLACK
02 BLANCO WHITE
77 NARANJA PALE ORANGE
83 AZUL FUERTE DARK BLUE
84 ROSA CLARO LIGHT PINK
85 VERDE PISTACHO PISTACHIO GREEN

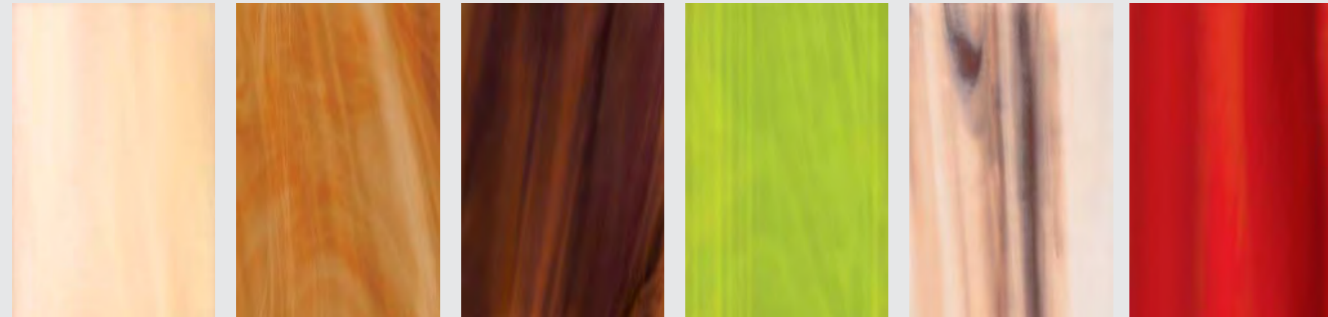

87 ARENA SAND
89 AMBAR OSCURO DARK AMBER
90 MARRÓN BROWN
92 VERDE LIMA LIME GREEN
95 BEIGE BEIGE
102 ROJO RED

directorio
acabados

directory
finishes

METAL / METAL

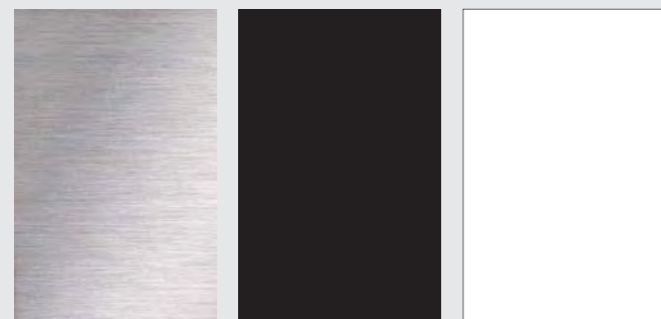

AISI 304 ACERO INOXIDABLE STAINLESS STEEL
NEGRO METAL PINTADO NEGRO BLACK PAINTED METAL
BLANCO METAL PINTADO BLANCO WHITE PAINTED METAL

POLICARBONATO / POLYCARBONATE
POLIPROPILENO / POLYPROPYLENE
POLIETILENO / POLYETHYLENE

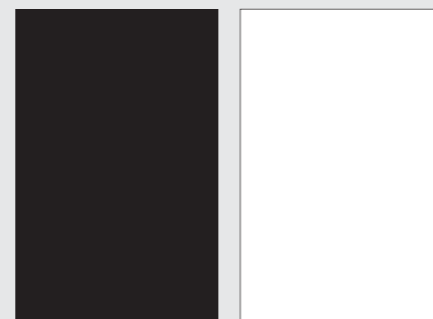

N TULIPA NEGRA BLACK LAMP SHADE
B TULIPA BLANCA WHITE LAMP SHADE

directorio
acabados
silicona

directory
silicone
finishes

167

arturo alvarez

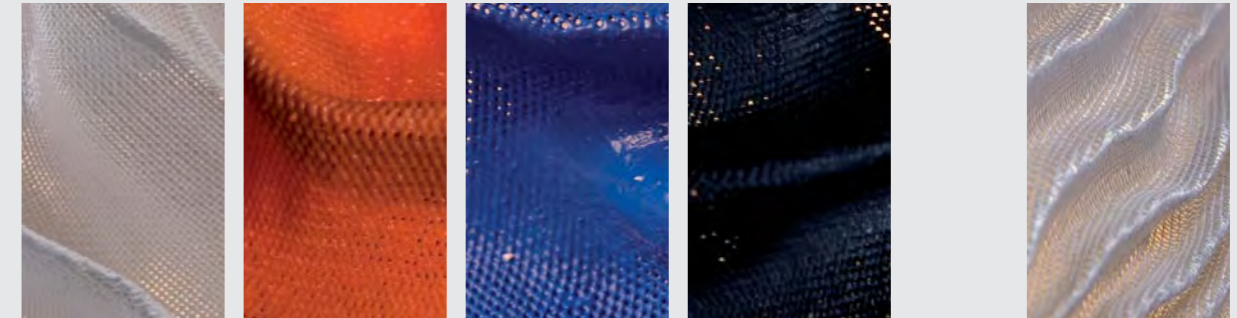

B BLANCO WHITE
NA NARANJA ORANGE
AZ AZUL BLUE
N NEGRO BLACK
PLANUM TEXTURA RUGOSA WAVY TEXTURE

directorio
acabados
tablero
marino

directory
plywood
finishes



BL BLANCO WHITE
WE WENGUÉ WENGE
AM AMARILLO YELLOW



TABLERO MARINO DE CONTRACHAPADO FENÓLICO DE ABEDUL. ACABADO FORMICA*
PHENOLIC COATED LAMINATED BIRCH PLYWOOD. FORMICA* FINISH

bety Pg. 145

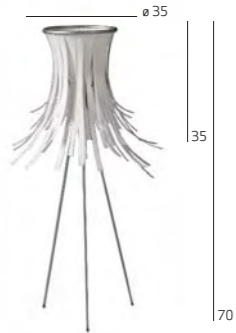

BE01
POLIPROPILENO / POLYPROPYLENE



METAL



- E14 - Max. 1x9 W
- E14 - Max. 1x11 W
- E14 ECO - Max. 1x42 W
- E14 - Max. 1x60 W



cebra Pg. 86

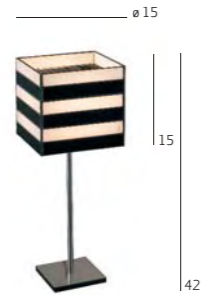

CE01
VIDRIO / GLASS



METAL



- E14 - Max. 1x9 W
- E14 - Max. 1x11 W
- E14 ECO - Max. 1x42 W
- E14 - Max. 1x60 W



curvas Pg. 70



CV01
VIDRIO / GLASS



METAL



- E14 - Max. 1x9 W
- E14 ECO - Max. 1x42 W
- E14 - Max. 1x60 W



domino Pg. 96



DM01
VIDRIO / GLASS



METAL



- E14 - Max. 1x9 W
- E14 ECO - Max. 1x42 W
- E14 - Max. 1x60 W



gilda Pg. 75

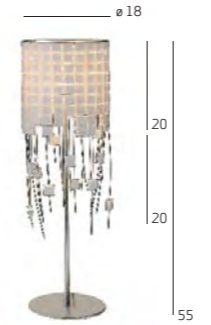

MOSAICO BISAZZA™ / BISAZZA™ MOSAIC

GD01B



METAL



- E14 - Max. 1x9 W
- E14 - Max. 1x11 W
- E14 ECO - Max. 1x42 W
- E14 - Max. 1x60 W



gluc Pg. 79

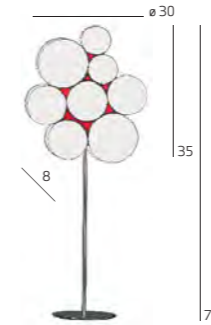

GL01
VIDRIO / GLASS



METAL



- E14 - Max. 1x11 W
- E14 ECO - Max. 1x42 W
- E14 - Max. 1x60 W



greta Pg. 99

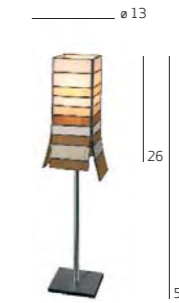

GR01

OPCIONES DE VIDRIO / GLASS OPTIONS



METAL



- E14 - Max. 1x9 W
- E14 - Max. 1x11 W
- E14 ECO - Max. 1x42 W
- E14 - Max. 1x60 W



iki Pg. 154,157



IK01
SILICONA / SILICONE



METAL



- E14 - Max. 2x11 W
- E14 ECO - Max. 2x42 W
- E14 - Max. 2x60 W



doscubos Pg. 84

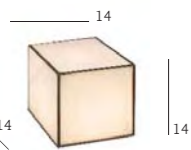

DO01G

VIDRIO / GLASS



METAL

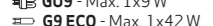

- GU9 - Max. 1x9 W
- G9 ECO - Max. 1x42 W
- G9 - Max. 1x60 W



doscubos Pg. 83

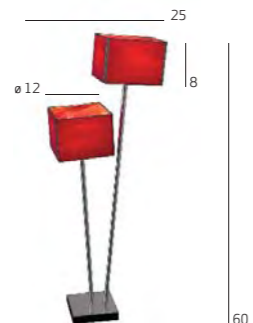

DO02

VIDRIO / GLASS



METAL



- GU9 - Max. 2x9 W
- G9 ECO - Max. 2x33 W
- G9 - Max. 2x40 W



encaixe Pg. 94

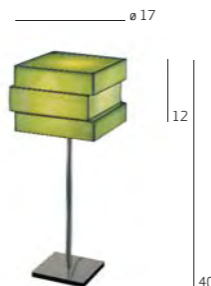

EN01

VIDRIO / GLASS



METAL



- E14 - Max. 1x9 W
- E14 ECO - Max. 1x42 W
- E14 - Max. 1x60 W



gea Pg. 19

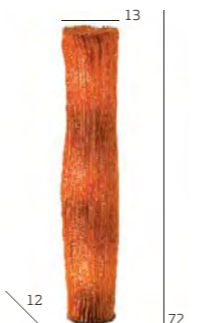

GE01

SILICONA / SILICONE



• Incluye Difusor / Diffuser included

- E14 - Max. 3x9 W
- E14 - Max. 3x11 W
- E14 ECO - Max. 3x42 W
- E14 - Max. 3x60 W



kono Pg. 103

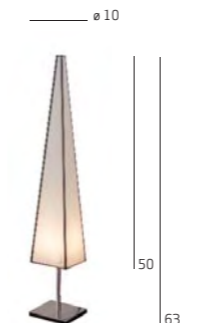

KN01

VIDRIO / GLASS



METAL



- G9 ECO - Max. 1x42 W
- G9 - Max. 1x60 W



lua Pg. 148, 150, 151, 153

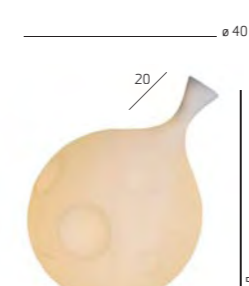

LU01

POLIETILENO / POLYETHYLENE



E27 - Max. 1x18 W

Largo de cable 4m. / Cable length 4m.

IP55

*In & out



nevo Pg. 26



NE01

SILICONA / SILICONE

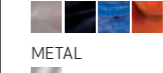

METAL



- E14 - Max. 2x9 W
- E14 - Max. 2x11 W
- E14 ECO - Max. 2x42 W
- E14 - Max. 2x60 W



nevo Pg. 27

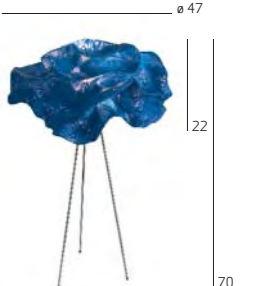

NE02

SILICONA / SILICONE

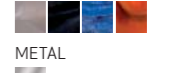

METAL



- E14 - Max. 2x9 W
- E14 - Max. 2x11 W
- E14 ECO - Max. 2x42 W
- E14 - Max. 2x60 W



nim Pg. 64

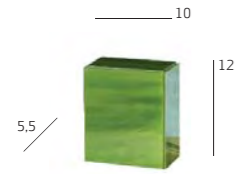

NM01
VIDRIO / GLASS
• GX53 - Max. 1x13 W
Opción bombillas de color /
Coloured bulb options

norman Pg. 56



NO01
VIDRIO / GLASS
METAL
• G24d2 - Max. 1x18 W

senda Pg. 104

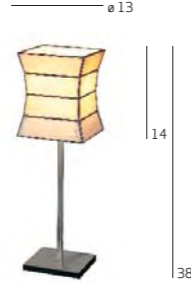

SN01
VIDRIO / GLASS
METAL
• E14 - Max. 1x9 W
• E14 - Max. 1x11 W
• E14 ECO - Max. 1x42 W
• E14 - Max. 1x60 W

senda Pg. 104

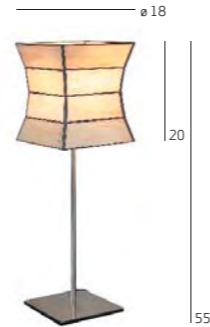

SN02
VIDRIO / GLASS
METAL
• E27 - Max. 1x18 W
• E27 ECO - Max. 1x42 W
• E27 - Max. 1x60 W

ventopop Pg. 114



VN01POP
OPCIONES DE VIDRIO / GLASS OPTIONS
Combinación POP / POP combination
METAL
• Incluye Difusor / Diffuser included
• GU9 - Max. 2x9 W
• G9 ECO - Max. 2x42 W (Philips)
• G9 ECO - Max. 2x33 W (Osram)

shio Pg. 12, 13

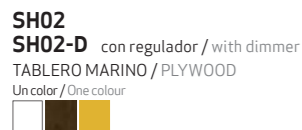

SH02
SH02-D con regulador / with dimmer
TABLERO MARINO / PLYWOOD
Un color / One colour
• Incluye Difusor / Diffuser included
• 2GX13 - Max. 1x22 W

sophi Pg. 88

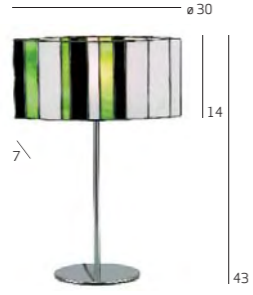

SP01
OPCIONES DE VIDRIO / GLASS OPTIONS
Un color / One colour
Marrón/Brown Ambar/Amber B&N/B&W
+otro / +other
METAL
• E14 - Max. 1x9 W
• E14 - Max. 1x11 W
• E14 ECO - Max. 1x42 W
• E14 - Max. 1x60 W

vento Pg. 50



VN01
OPCIONES DE VIDRIO / GLASS OPTIONS
Un color / One colour
Malva/Mauve Marrón/Brown B&N/B&W
METAL
• Incluye Difusor / Diffuser included
• GU9 - Max. 2x9 W
• G9 ECO - Max. 2x42 W (Philips)
• G9 ECO - Max. 2x33 W (Osram)

vento Pg. 52



VN02
OPCIONES DE VIDRIO / GLASS OPTIONS
Un color / One colour
Malva/Mauve Marrón/Brown B&N/B&W
METAL
• Incluye Difusor / Diffuser included
• GU9 - Max. 4x9 W
• G9 ECO - Max. 4x42 W (Philips)
• G9 ECO - Max. 4x33 W (Osram)

ventopop



VN02POP
OPCIONES DE VIDRIO / GLASS OPTIONS
Combinación POP / POP combination
METAL
• Incluye Difusor / Diffuser included
• GU9 - Max. 4x9 W
• G9 ECO - Max. 4x42 W (Philips)
• G9 ECO - Max. 4x33 W (Osram)

aros Pg. 122, 123

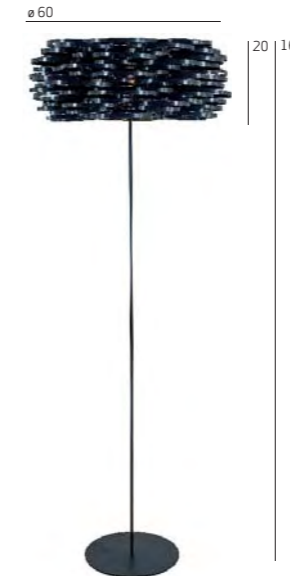

AR03
POLIPROPILENO
POLYPROPYLENE

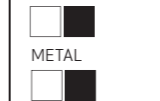

• Incluye Difusor / Diffuser included
• E27 - Max. 1x18 W
• E27 - Max. 1x20 W
• E27 ECO - Max. 1x70 W
• E27 - Max. 1x100 W

aros Pg. 122

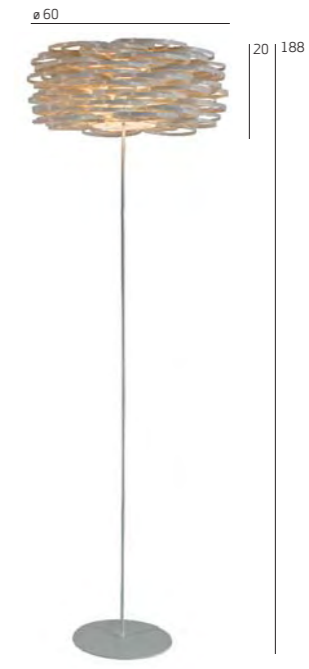

AR03G
POLIPROPILENO
POLYPROPYLENE



• Incluye Difusor / Diffuser included
• E27 - Max. 1x18 W
• E27 - Max. 1x20 W
• E27 ECO - Max. 1x70 W
• E27 - Max. 1x100 W

bety Pg. 142, 144

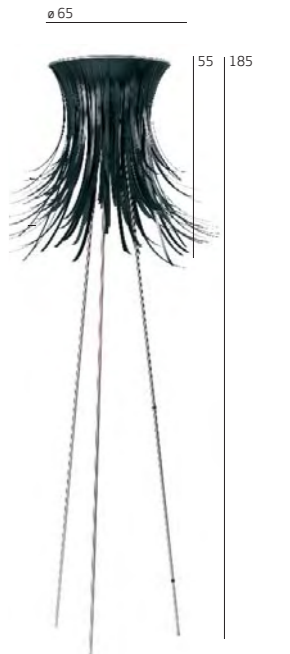

BE03
POLIPROPILENO
POLYPROPYLENE



• E27 - Max. 1x18 W
• E27 - Max. 1x20 W
• E27 ECO - Max. 1x70 W
• E27 - Max. 1x100 W

cebra



CE03
VIDRIO / GLASS

METAL

- E27 - Max. 1x18 W
- E27 - Max. 1x20 W
- E27 ECO - Max. 1x70 W
- E27 - Max. 1x100 W

curvas Pg. 68

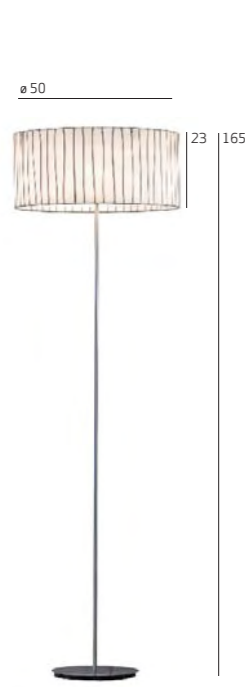

CV03G
VIDRIO / GLASS

METAL

- Incluye Regulador / Dimmer included
- Incluye Difusor / Diffuser included
- E27 - Max. 4x18 W
- E27 Dimmer - Max. 4x18 W
- E27 ECO - Max. 4x70 W
- E27 - Max. 4x100 W

doscubos Pg. 83

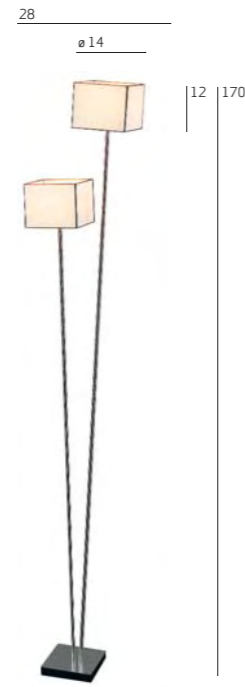

DO03
VIDRIO / GLASS

METAL

- E14 - Max. 2x9 W
- E14 ECO - Max. 2x42 W
- E14 - Max. 2x60 W

encaixe Pg. 92, 93, 95

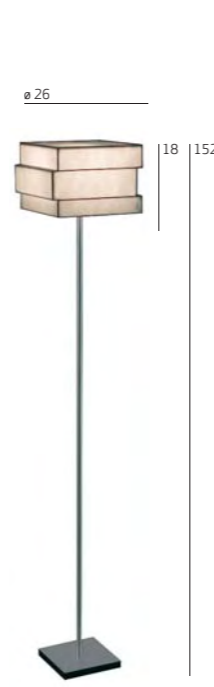

EN03
VIDRIO / GLASS

METAL

- E27 - Max. 1x18 W
- E27 ECO - Max. 1x70 W
- E27 - Max. 1x100 W

gea Pg. 16, 17, 18, 21



GE03
SILICONA / SILICONE

- Incluye Regulador / Dimmer included
- Incluye Difusor / Diffuser included
- E27 - Max. 5x18 W
- E27 Dimmer - Max. 5x18 W
- E27 ECO - Max. 5x70 W
- E27 - Max. 5x100 W

GOOD DESIGN 2008

gilda Pg. 74

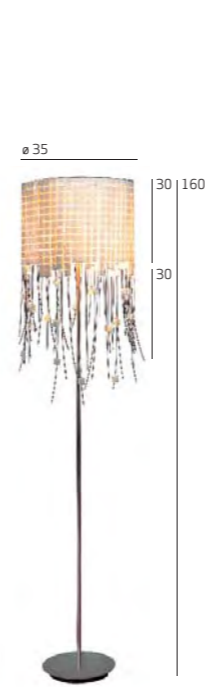

MOSAICO BISAZZA™ / BISAZZA™ MOSAIC

GD03B

GD03BO 24k

GD03N

GD03NO 24k

METAL

- Incluye Regulador / Dimmer included
- E27 - Max. 3x18 W
- E27 Dimmer - Max. 3x18 W
- E27 ECO - Max. 3x42 W
- E27 - Max. 3x60 W

metrica Pg. 40, 41, 43

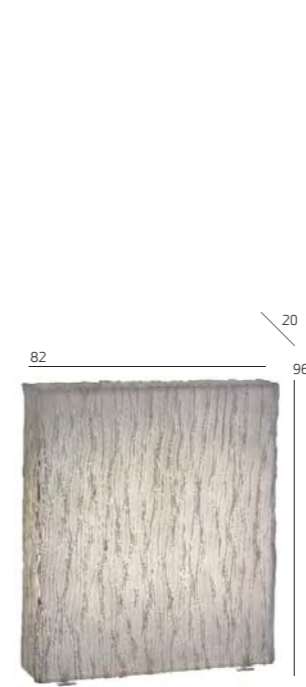

MT03
SILICONA / SILICONE

METAL

- Enlazable, máximo 5 unidades / Linkage up to 5 units
- G5 - Max. 4x24 W

Opción bombillas de color / Coloured bulb options

shio Pg. 14

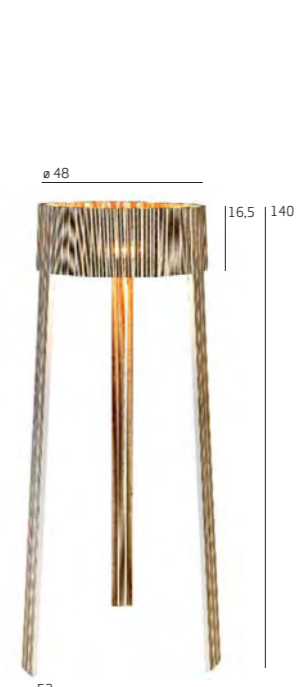

SH03
SH03-D con regulador / with dimmer

TABLERO MARINO / PLYWOOD

Un color / One colour

- Incluye Difusor / Diffuser included
- 2GX13 - Max. 1x55 W

v Pg. 138, 141

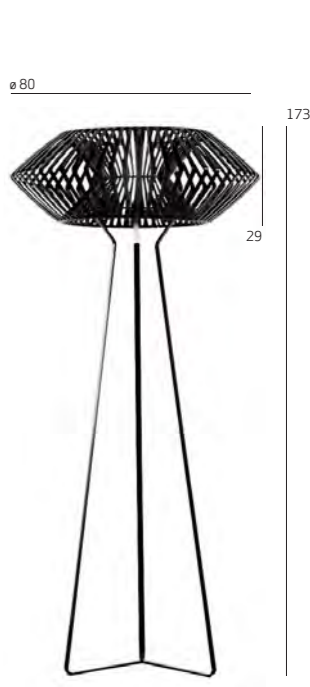

VV03
POLICARBONATO / POLYCARBONATE

METAL

- Incluye Difusor / Diffuser included
- E27 - Max. 1x18 W
- E27 ECO - Max. 1x70 W
- E27 - Max. 1x100 W

aros Pg. 118, 119, 120

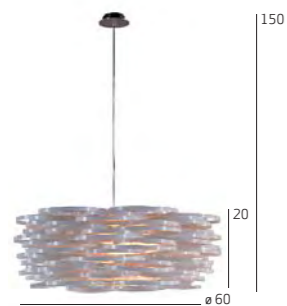

AR04
POLIPROPILENO / POLYPROPYLENE

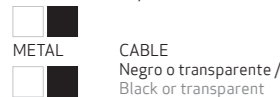

- E27 - Max. 1x18W
- E27 - Max. 1x20W
- E27 ECO - Max. 1x70W
- E27 - Max. 1x100W



bety Pg. 146

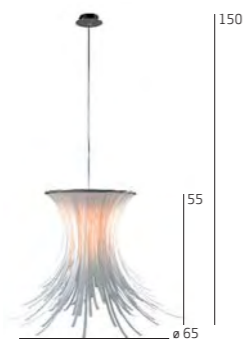

BE04
POLIPROPILENO / POLYPROPYLENE

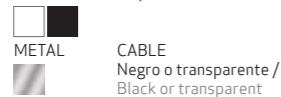

- E27 - Max. 1x18W
- E27 - Max. 1x20W
- E27 ECO - Max. 1x70W
- E27 - Max. 1x100W



bety Pg. 146



BE04-1
POLIPROPILENO / POLYPROPYLENE

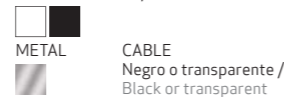

- E14 - Max. 1x9W
- E14 - Max. 1x11W
- E14 ECO - Max. 1x42W
- E14 - Max. 1x60W



cebra

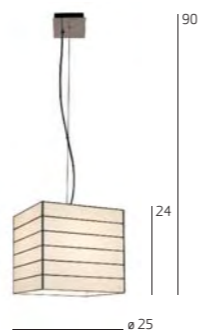

CE04
VIDRIO / GLASS



METAL SOPORTE / FRAME
Tensores / Tie rod

CABLE
Negro o transparente / Black or transparent

- E27 - Max. 1x18W
- E27 - Max. 1x20W
- E27 ECO - Max. 1x70W
- E27 - Max. 1x100W



cebra

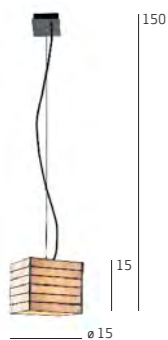

CE04-1
VIDRIO / GLASS



METAL

SOPORTE / FRAME
Tensores / Tie rod

CABLE
Negro o transparente / Black or transparent

- E14 - Max. 1x9W
- E14 - Max. 1x11W
- E14 ECO - Max. 1x42W
- E14 - Max. 1x60W



curvas Pg. 66, 67, 69



CV04G
VIDRIO / GLASS



METAL SOPORTE / FRAME
Tensores / Tie rod

CABLE
Transparente / Transparent

• Incluye Difusor / Diffuser included

- E27 - Max. 4x18W
- E27 ECO - Max. 4x70W
- E27 - Max. 4x100W



curvas Pg. 69

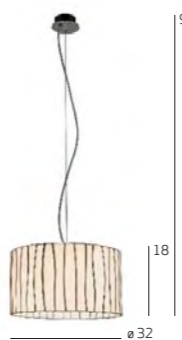

CV04
VIDRIO / GLASS



METAL SOPORTE / FRAME
Tensores / Tie rod

CABLE
Transparente / Transparent

• Incluye Difusor / Diffuser included

- E27 - Max. 1x18W
- E27 - Max. 1x20W
- E27 ECO - Max. 1x70W
- E27 - Max. 1x100W



curvas Pg. 69

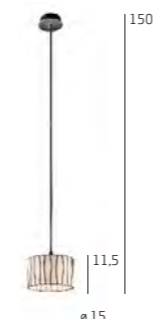

CV04-1
VIDRIO / GLASS



METAL

CABLE
Negro o transparente / Black or transparent

- E14 - Max. 1x9W
- E14 ECO - Max. 1x42W
- E14 - Max. 1x60W



domino Pg. 97

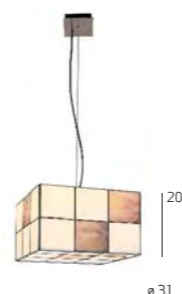

DM04
VIDRIO / GLASS



METAL SOPORTE / FRAME
Tensores / Tie rod

CABLE
Negro o transparente / Black or transparent

- E14 - Max. 4x11W
- E14 ECO - Max. 4x42W
- E14 - Max. 4x60W



doscubos Pg. 84

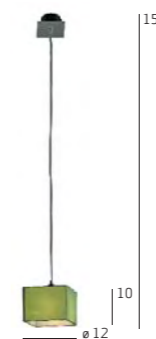

D004-1
VIDRIO / GLASS



METAL

CABLE
Negro o transparente / Black or transparent

- E14 - Max. 1x9W
- E14 ECO - Max. 1x42W
- E14 - Max. 1x60W



encaixe Pg. 95

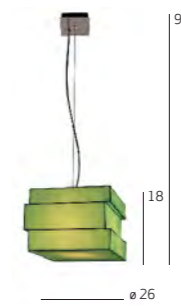

EN04
VIDRIO / GLASS



METAL SOPORTE / FRAME
Tensores / Tie rod

CABLE
Negro o transparente / Black or transparent

- E27 - Max. 1x18W
- E27 ECO - Max. 1x70W
- E27 - Max. 1x100W



encaixe Pg. 95

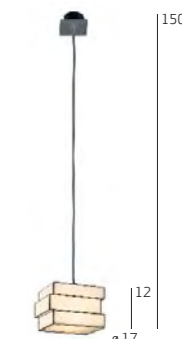

EN04-1
VIDRIO / GLASS



METAL

CABLE
Negro o transparente / Black or transparent

- E14 - Max. 1x9W
- E14 ECO - Max. 1x42W
- E14 - Max. 1x60W



fluo Pg. 124, 125, 126, 127, 128



FLO4
ACERO / STEEL

* A partir de 5 unidades, elegir color RAL Classic. / For orders from 5 units, choose RAL Classic colour.

METAL

CABLE
Transparente / Transparent

- E27 - Max. 1x20W
- E27 - Max. 1x100W



gea Pg. 20



GE04
SILICONA / SILICONE

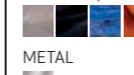

METAL

CABLE
Transparente / Transparent

- E27 - Max. 1x18W
- E27 ECO - Max. 1x70W
- E27 - Max. 1x100W



gilda Pg. 72, 73, 77

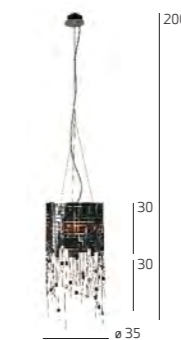

MOSAICO BISAZZA™ / BISAZZA™ MOSAIC
GD04B
METAL



METAL

SOPORTE / FRAME
Tensores / Tie rod

CABLE
Cable malla de acero / Cable of metallic mesh

- E27 - Max. 3x18W
- E27 ECO - Max. 3x42W
- E27 - Max. 3x60W



gilda Pg. 77



MOSAICO BISAZZA™ / BISAZZA™ MOSAIC
GD04-1B
METAL



METAL

SOPORTE / FRAME
Tensores / Tie rod

CABLE
Cable malla de acero / Cable of metallic mesh

- E14 - Max. 1x9W
- E14 - Max. 1x11W
- E14 ECO - Max. 1x42W
- E14 - Max. 1x60W





iki Pg. 156, 158, 159

150
20
120
30

IK04
SILICONA / SILICONE

METAL

SOPORTE / FRAME
Tensores / Tie rod

CABLE
Transparente / Transparent

E27 - Max. 2x18 W
E27 ECO - Max. 2x70 W
E27 - Max. 2x100 W

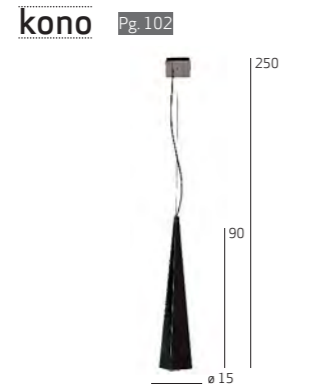

kono Pg. 102

250
90
ø 15

KN04G
VIDRIO / GLASS

METAL SOPORTE / FRAME
Tensores / Tie rod

CABLE
Negro o transparente / Black or transparent

E27 - Max. 1x18 W
E27 ECO - Max. 1x70 W
E27 - Max. 1x100 W

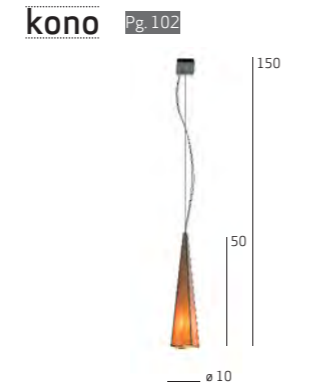

kono Pg. 102

150
150
ø 10

KN04-1
VIDRIO / GLASS

METAL SOPORTE / FRAME
Tensores / Tie rod

CABLE
Negro o transparente / Black or transparent

E14 - Max. 1x11 W
E14 ECO - Max. 1x42 W
E14 - Max. 1x60 W

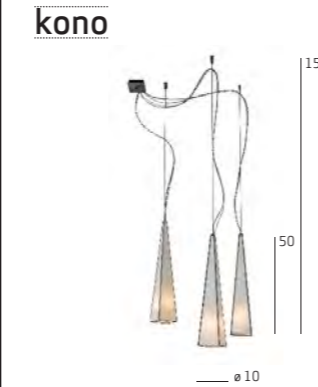

kono

150
150
ø 10

KN04-3
VIDRIO / GLASS

METAL SOPORTE / FRAME
Tensores / Tie rod

CABLE
Transparente / Transparent

E14 - Max. 3x11 W
E14 ECO - Max. 3x42 W
E14 - Max. 3x60 W

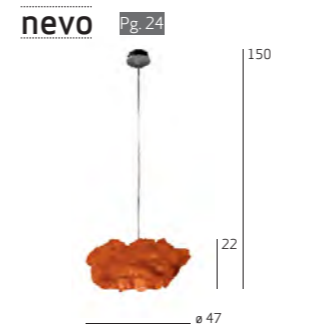

nevo Pg. 24

150
22
ø 47

NE04-1
SILICONA / SILICONE

METAL

CABLE
Transparente / Transparent

E14 - Max. 2x9 W
E14 - Max. 2x11 W
E14 ECO - Max. 2x42 W
E14 - Max. 2x60 W



nim Pg. 60, 61, 63

150
5,5
ø 10

NM04-1
VIDRIO / GLASS

CABLE
Negro / Black

GX53 - Max. 1x13 W

Opción bombillas de color /
Coloured bulb options

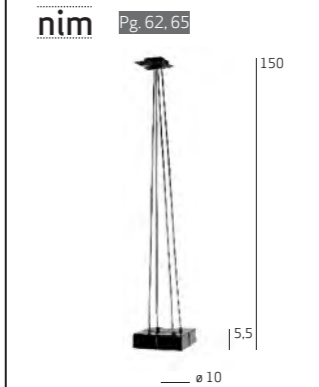

nim Pg. 62, 65

150
5,5
ø 10

NM04-4
VIDRIO / GLASS

CABLE
Negro / Black

GX53 - Max. 4x9 W

Opción bombillas de color /
Coloured bulb options

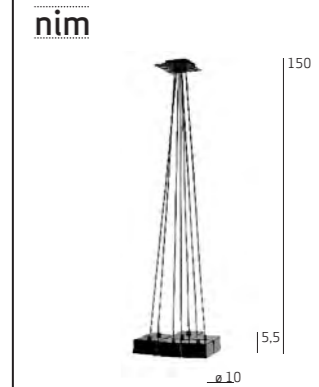

nim

150
5,5
ø 10

NM04-7
VIDRIO / GLASS

CABLE
Negro / Black

GX53 - Max. 7x9 W

Opción bombillas de color /
Coloured bulb options



lua Pg. 152, 153

150
20
160
ø 40

LU04
POLIETILENO / POLYETHYLENE

METAL

CABLE
Transparente / Transparent

E27 - Max. 1x18 W

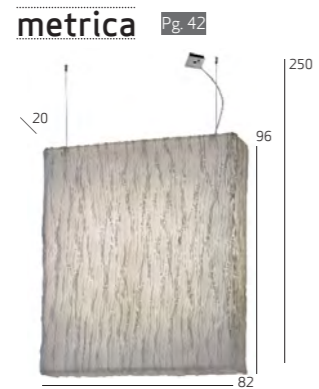

metrica Pg. 42

250
20
96
82

MT04
SILICONA / SILICONE

METAL SOPORTE / FRAME
Tensores / Tie rod

CABLE
Transparente / Transparent

Incluye Difusor / Diffuser included
Enlazable, máximo 5 unidades / Linkage
up to 5 units

G5 - Max. 4x24 W

Opción bombillas de color /
Coloured bulb options



nevo Pg. 22, 23, 24

200
30
ø 100

NE04G
SILICONA / SILICONE

METAL

SOPORTE / FRAME
Tensores / Tie rod

CABLE
Transparente / Transparent

Incluye Difusor / Diffuser included

E27 - Max. 4x18 W
E27 ECO - Max. 4x70 W
E27 - Max. 4x100 W



nevo Pg. 24, 25

150
25
ø 70

NE04
SILICONA / SILICONE

METAL

SOPORTE / FRAME
Tensores / Tie rod

CABLE
Transparente / Transparent

Incluye Difusor / Diffuser included

E27 - Max. 3x18 W
E27 ECO - Max. 3x70 W
E27 - Max. 3x100 W

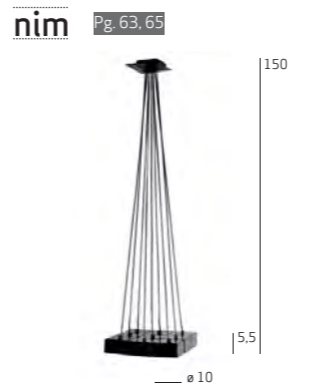

nim Pg. 63, 65

150
5,5
ø 10

NM04-9
VIDRIO / GLASS

CABLE
Negro / Black

GX53 - Max. 9x9 W

Opción bombillas de color /
Coloured bulb options

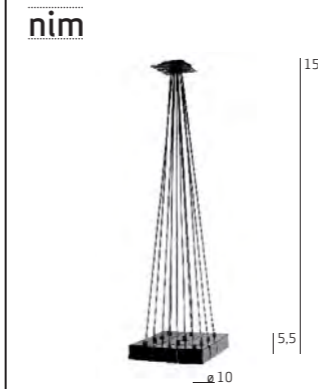

nim

150
5,5
ø 10

NM04-12
VIDRIO / GLASS

CABLE
Negro / Black

GX53 - Max. 12x9 W

Opción bombillas de color /
Coloured bulb options



norman Pg. 54, 55, 57

150
9,5
6,5
119

N004
VIDRIO / GLASS

METAL

SOPORTE / FRAME
Tensores / Tie rod

CABLE
Negro o transparente / Black or transparent

G5 - Max. 1x54 W

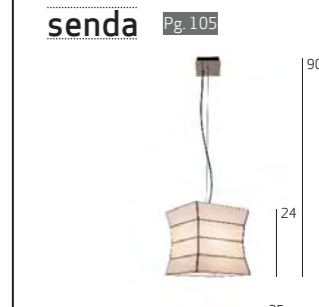

senda Pg. 105

90
24
ø 25

SN04
VIDRIO / GLASS

METAL SOPORTE / FRAME
Tensores / Tie rod

CABLE
Negro o transparente / Black or transparent

E27 - Max. 1x18 W
E27 - Max. 1x20 W
E27 ECO - Max. 1x70 W
E27 - Max. 1x100 W

senda Pg. 105

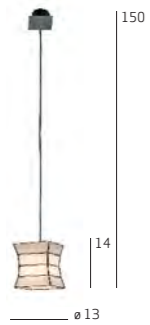

SN04-1
VIDRIO / GLASS
Un color / One colour

METAL

CABLE
Negro o transparente / Black or transparent

E14 - Max. 1x9 W
E14 - Max. 1x11 W
E14 ECO - Max. 1x42 W
E14 - Max. 1x60 W

shio Pg. 8, 9, 10



SH04
SH04-D con regulador / with dimmer
TABLERO MARINO / PLYWOOD
Un color / One colour

METAL SOPORTE / FRAME
Tensores / Tie rod

CABLE
Negro o transparente / Black or transparent
• Incluye Difusor / Diffuser included

2GX13 - Max. 1x55 W

shio Pg. 11

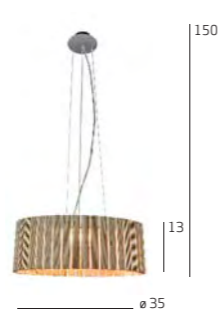

SH04-1
SH04-1-D con regulador / with dimmer
TABLERO MARINO / PLYWOOD
Un color / One colour

METAL SOPORTE / FRAME
Tensores / Tie rod

CABLE
Negro o transparente / Black or transparent
• Incluye Difusor / Diffuser included

2GX13 - Max. 1x22 W

sombras Pg. 107

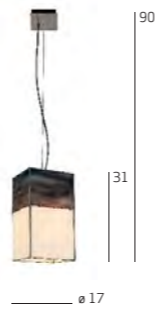

S004
VIDRIO / GLASS
Un color / One colour

METAL SOPORTE / FRAME
Tensores / Tie rod

CABLE
Negro o transparente / Black or transparent

E27 - Max. 1x18 W
E27 ECO - Max. 1x70 W
E27 - Max. 1x100 W

vento Pg. 46, 47, 48

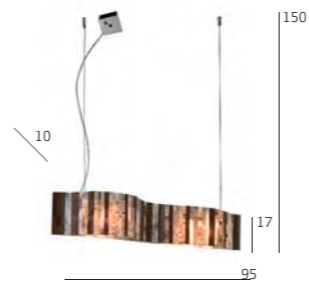

VN04
OPCIONES DE VIDRIO / GLASS OPTIONS
Un color / One colour

METAL

Malva/Mauve Marrón/Brown B&N/B&W

SOPORTE / FRAME
Tensores / Tie rod

CABLE
Transparente / Transparent

GU9 - Max. 4x9 W
G9 ECO - Max. 4x42 W (Philips)
G9 ECO - Max. 4x33 W (Osram)

vento Pg. 49

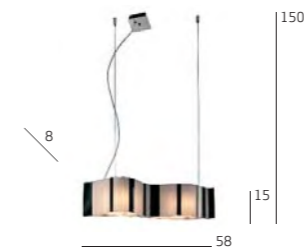

VN04-1
OPCIONES DE VIDRIO / GLASS OPTIONS
Un color / One colour

METAL

Malva/Mauve Marrón/Brown B&N/B&W

SOPORTE / FRAME
Tensores / Tie rod

CABLE
Transparente / Transparent

GU9 - Max. 2x9 W
G9 ECO - Max. 2x42 W (Philips)
G9 ECO - Max. 2x33 W (Osram)

ventopop Pg. 112, 113, 115



VN04POP
OPCIONES DE VIDRIO / GLASS OPTIONS
Combinación POP / POP combination

METAL

SOPORTE / FRAME
Tensores / Tie rod

CABLE
Transparente / Transparent

GU9 - Max. 4x9 W
G9 ECO - Max. 4x42 W (Philips)
G9 ECO - Max. 4x33 W (Osram)

ventopop

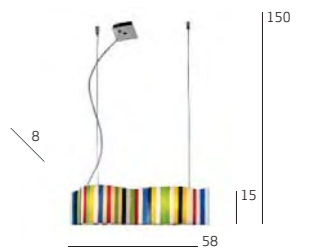

VN041POP
OPCIONES DE VIDRIO / GLASS OPTIONS
Combinación POP / POP combination

METAL

SOPORTE / FRAME
Tensores / Tie rod

CABLE
Transparente / Transparent

GU9 - Max. 2x9 W
G9 ECO - Max. 2x42 W (Philips)
G9 ECO - Max. 2x33 W (Osram)

sombras Pg. 107

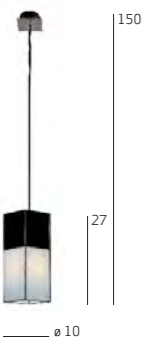

S004-1
VIDRIO / GLASS
Un color / One colour

METAL

CABLE
Negro o transparente / Black or transparent

E14 - Max. 1x9 W
E14 - Max. 1x11 W
E14 ECO - Max. 1x42 W
E14 - Max. 1x60 W

sophi Pg. 89



SP04
OPCIONES VIDRIO / GLASS OPTIONS
Un color / One colour

Marrón/Brown Ambar/Amber B&N/B&W +otro +other

METAL CABLE
Negro o transparente
Black or transparent

E27 - Max. 1x18 W
E27 ECO - Max. 1x70 W
E27 - Max. 1x100 W

sophi Pg. 90

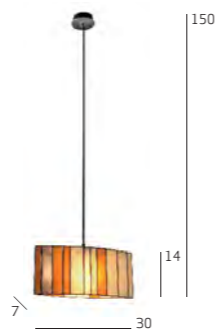

SP04-1
OPCIONES DE VIDRIO / GLASS OPTIONS
Un color / One colour

Marrón/Brown Ambar/Amber B&N/B&W +otro +other

METAL CABLE
Negro o transparente
Black or transparent

E14 - Max. 1x9 W
E14 - Max. 1x11 W
E14 ECO - Max. 1x42 W
E14 - Max. 1x60 W

uxi Pg. 30, 31, 33



UX04
UX04-D con regulador / with dimmer
TABLERO MARINO / PLYWOOD
Un color / One colour

METAL SOPORTE / FRAME
Tensores / Tie rod

CABLE
Transparente / Transparent
• Incluye Difusor / Diffuser included

G5 - Max. 2x39 W

V Pg. 136

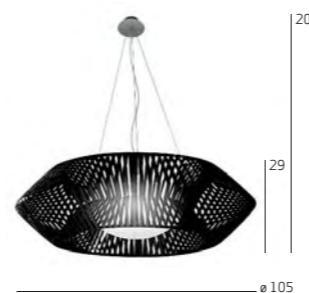

VV04G
POLICARBONATO / POLYCARBONATE

METAL

SOPORTE / FRAME
Tensores / Tie rod

CABLE
Transparente / Transparent
• Incluye Difusor / Diffuser included

E27 - Max. 4x18 W
E27 ECO - Max. 4x70 W
E27 - Max. 4x100 W

V Pg. 136, 140



VV04
POLICARBONATO / POLYCARBONATE

METAL

SOPORTE / FRAME
Tensores / Tie rod

CABLE
Transparente / Transparent
• Incluye Difusor / Diffuser included

E27 - Max. 1x18 W
E27 ECO - Max. 1x70 W
E27 - Max. 1x100 W

directorio
regletas

directory
strip

arturo alvarez

cebra

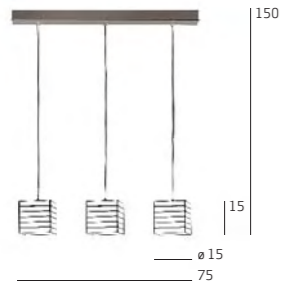

CE04-3

VIDRIO / GLASS



METAL

- E14 - Max. 3x9 W
- E14 - Max. 3x11 W
- E14 ECO - Max. 3x42 W
- E14 - Max. 3x60 W

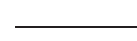

cebra

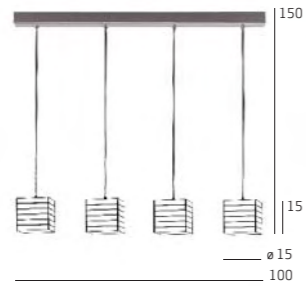

CE04-4

VIDRIO / GLASS



METAL

- E14 - Max. 4x9 W
- E14 - Max. 4x11 W
- E14 ECO - Max. 4x42 W
- E14 - Max. 4x60 W

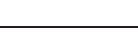

curvas

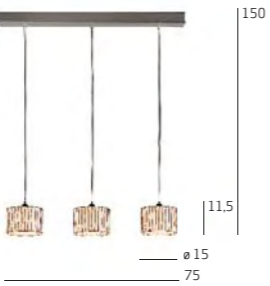

CV04-3

VIDRIO / GLASS



METAL

- E14 - Max. 3x9 W
- E14 ECO - Max. 3x42 W
- E14 - Max. 3x60 W

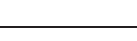

curvas

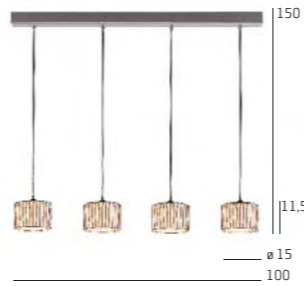

CV04-4

VIDRIO / GLASS



METAL

- E14 - Max. 4x9 W
- E14 ECO - Max. 4x42 W
- E14 - Max. 4x60 W

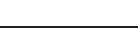

senda

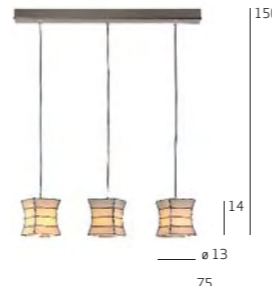

SN04-3

VIDRIO / GLASS



METAL

- E14 - Max. 3x9 W
- E14 - Max. 3x11 W
- E14 ECO - Max. 3x42 W
- E14 - Max. 3x60 W

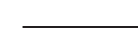

senda

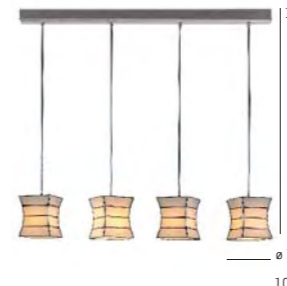

SN04-4

VIDRIO / GLASS



METAL

- E14 - Max. 4x9 W
- E14 - Max. 4x11 W
- E14 ECO - Max. 4x42 W
- E14 - Max. 4x60 W

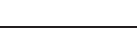

sophi

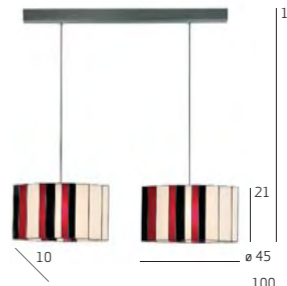

SP04G-2

OPCIONES DE VIDRIO / GLASS OPTIONS

Un color / One colour



Marrón/Brown Ambar/Amber B&N/B&W +otro +other

METAL

- E27 - Max. 2x18 W
- E27 ECO - Max. 2x70 W
- E27 - Max. 2x100 W



doscubos

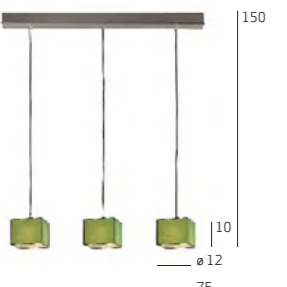

D004-3

VIDRIO / GLASS



METAL

- E14 - Max. 3x9 W
- E14 ECO - Max. 3x42 W
- E14 - Max. 3x60 W



doscubos Pg. 82

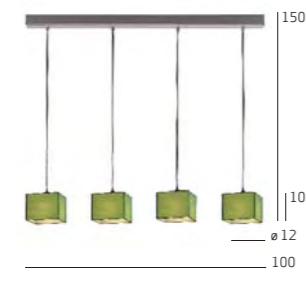

D004-4

VIDRIO / GLASS



METAL

- E14 - Max. 4x9 W
- E14 ECO - Max. 4x42 W
- E14 - Max. 4x60 W

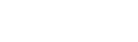

encaixe

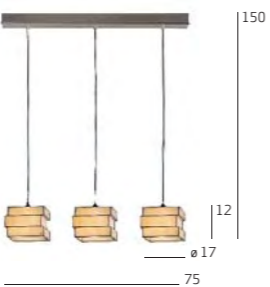

EN04-3

VIDRIO / GLASS



METAL

- E14 - Max. 3x9 W
- E14 ECO - Max. 3x42 W
- E14 - Max. 3x60 W



encaixe

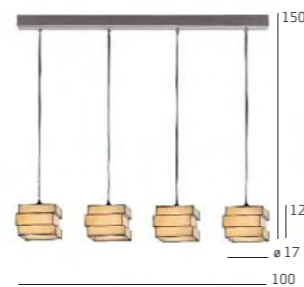

EN04-4

VIDRIO / GLASS



METAL

- E14 - Max. 4x9 W
- E14 ECO - Max. 4x42 W
- E14 - Max. 4x60 W



directorio
acabados
regleta

directory
strip
finishes



ACERO INOXIDABLE / STAINLESS STEEL

METAL



CABLE

Transparente / Transparent



NEGRO / BLACK

METAL



CABLE

Negro / Black

apliques Pg. 108

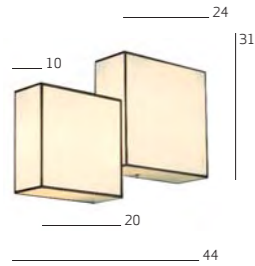

A0501
VIDRIO / GLASS

G24d1 - Max. 4x13 W

apliques Pg. 109

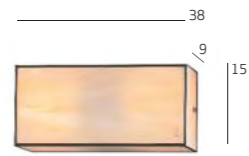

A0604
VIDRIO / GLASS

E14 - Max. 2x11 W
E14 ECO - Max. 2x42 W
E14 - Max. 2x60 W

apliques Pg. 109



SL06
METAL
GU9 - Max. 3x9 W
G9 ECO - Max. 3x42 W
G9 - Max. 3x60 W

cebra Pg. 87

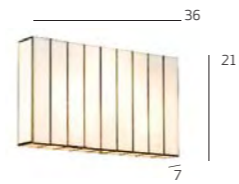

CE06
VIDRIO / GLASS

G24d1 - Max. 3x13 W

cebra

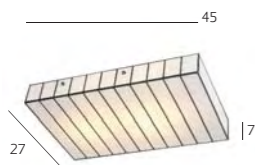

CE05
VIDRIO / GLASS

G24d1 - Max. 4x13 W

curvas Pg. 71

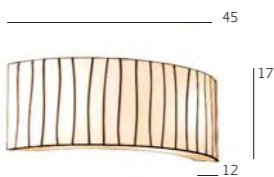

CV06
VIDRIO / GLASS

E14 - Max. 2x11 W
E14 ECO - Max. 2x42 W
E14 - Max. 2x60 W

doscubos Pg. 85

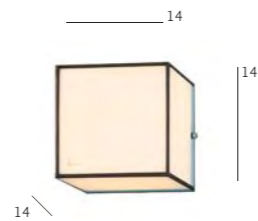

D006G
VIDRIO / GLASS

GU9 - Max. 1x9 W
G9 ECO - Max. 1x33 W
G9 - Max. 1x40 W

domino Pg. 97

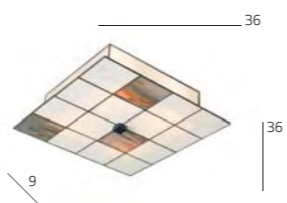

DM05
VIDRIO / GLASS

E14 - Max. 4x11 W
E14 ECO - Max. 4x28 W
E14 - Max. 4x40 W

exterior Pg. 110

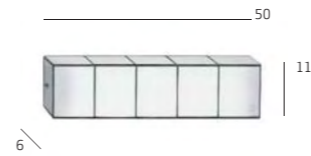

EXCE06
VIDRIO / GLASS
2G11 - Max. 1x36 W

exterior Pg. 111



EXCU06
VIDRIO / GLASS
G24d3 - Max. 1x26 W

exterior Pg. 111

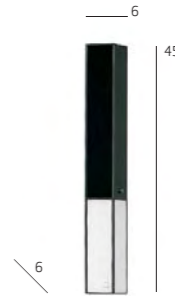

EXS006
VIDRIO / GLASS
G24d3 - Max. 1x26 W

gilda Pg. 76

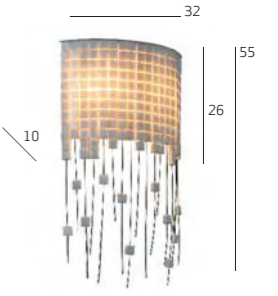

MOSAICO BISAZZA™ / BISAZZA™ MOSAIC
GD06-BB
GD06-BB0

GD06-BN
GD06-BNO

G24d2 - Max. 2x18 W

gluc Pg. 78

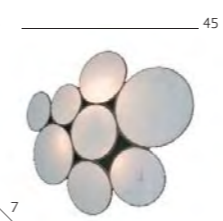

GL06
VIDRIO / GLASS

GU9 - Max. 3x9 W
G9 ECO - Max. 3x33 W
G9 - Max. 3x40 W

gluc Pg. 79

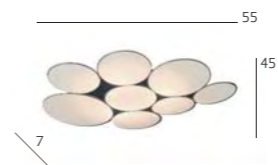

GL05
VIDRIO / GLASS

GU9 - Max. 3x9 W
G9 ECO - Max. 3x33 W
G9 - Max. 3x40 W

guau Pg. 130, 132, 133, 134, 135

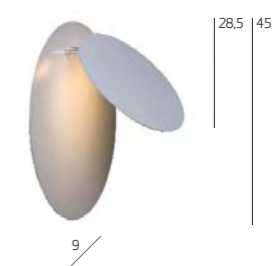

GU06
METAL
GX53 - Max. 3x9 W
Opción bombillas de color / Coloured bulb options

reddot design award
winner 2010

guau Pg. 133

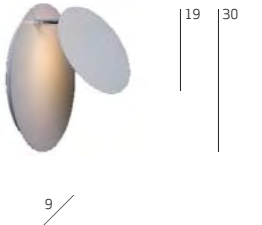

GU06P
METAL
GX53 - Max. 1x13 W
Opción bombillas de color / Coloured bulb options

greta Pg. 98

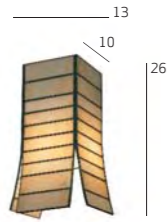

GR06
OPCIONES DE VIDRIO / GLASS OPTIONS
Un color / One colour B&N / B&W + otro / + other

Verde / Green Ambar / Amber Marrón / Brown

E14 - Max. 1x11 W
E14 ECO - Max. 1x42 W
E14 - Max. 1x60 W

hexa Pg. 34, 35

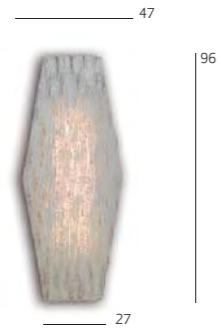

HE06
HE06-D con regulador / with dimmer
SILICONA / SILICONE

• Textura rugosa / Wavy texture

G5 - Max. 2x24 W

Opción bombillas de color / Coloured bulb options

nevo Pg. 28



NE06
SILICONA / SILICONE

E14 - Max. 2x9 W
E14 ECO - Max. 2x42 W
E14 - Max. 2x60 W

nevo Pg. 28



NE06P
SILICONA / SILICONE

GU9 - Max. 1x9 W
G9 ECO - Max. 1x42 W
G9 - Max. 1x60 W

norman Pg. 59

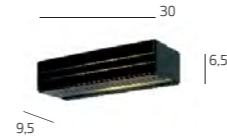

NO06P
VIDRIO / GLASS

G24d2 - Max. 1x18 W

nim Pg. 64



NM06
VIDRIO / GLASS

GX53 - Max. 1x13 W

Opción bombillas de color / Coloured bulb options

planum Pg. 36, 37, 38, 39

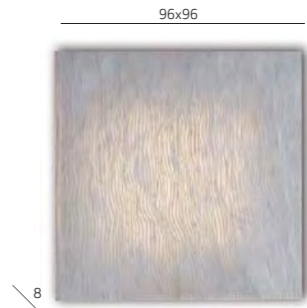

PM06R
PM06R-D con regulador / with dimmer
SILICONA / SILICONE

• Textura rugosa / Wavy texture

G5 - Max. 4x24 W

Opción bombillas de color / Coloured bulb options

planum Pg. 36

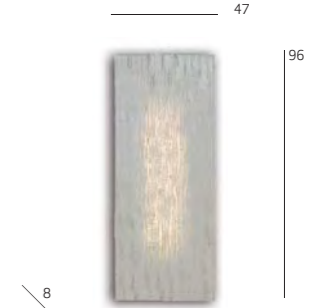

PM06PR
PM06PR-D con regulador / with dimmer
SILICONA / SILICONE

• Textura rugosa / Wavy texture

G5 - Max. 2x24 W

Opción bombillas de color / Coloured bulb options

nevo Pg. 24

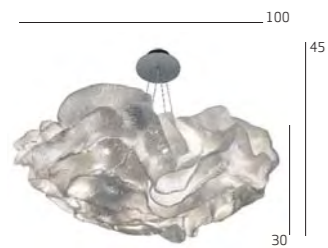

NE04G (Uso Plafón / Ceiling use)
SILICONA / SILICONE

METAL

SOPORTE / FRAME
Tensores / Tie rod

CABLE
Negro o transparente / Black or transparent
• Incluye Difusor / Diffuser included

E27 - Max. 4x18 W
E27 ECO - Max. 4x70 W
E27 - Max. 4x100 W

nevo Pg. 24

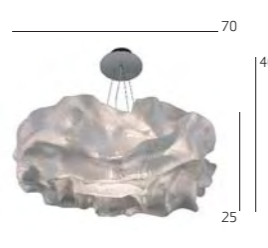

NE04 (Uso Plafón / Ceiling use)
SILICONA / SILICONE

METAL

SOPORTE / FRAME
Tensores / Tie rod

CABLE
Negro o transparente / Black or transparent
• Incluye Difusor / Diffuser included

E27 - Max. 3x18 W
E27 ECO - Max. 3x70 W
E27 - Max. 3x100 W

norman Pg. 58



NO06
VIDRIO / GLASS

G5 - Max. 1x54 W

shio Pg. 15



SH06
SH06-D con regulador / with dimmer
TABLERO MARINO / PLYWOOD

Un color / One colour

• Incluye Difusor / Diffuser included

G24q2 - Max. 2x18 W

sombras Pg. 106

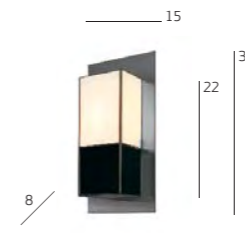

S006
VIDRIO / GLASS

METAL

G24d1 - Max. 1x13 W

sophi Pg. 91

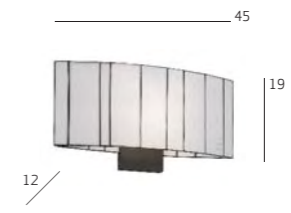

SP06
OPCIONES DE VIDRIO / GLASS OPTIONS
Un color / One colour

Marrón / Brown Ambar / Amber B&N / B&W + otro / + other

MADERA / WOOD

G24d2 - Max. 2x18 W

sophi Pg. 91

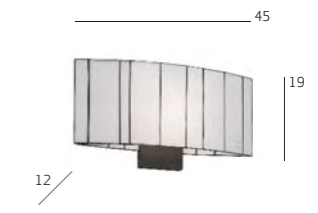

SP06B
OPCIONES DE VIDRIO / GLASS OPTIONS
Un color / One colour

Marrón / Brown Ambar / Amber B&N / B&W + otro / + other

MADERA / WOOD

E14 ECO - Max. 2x42 W
E14 - Max. 2x60 W

uxi Pg. 32



64

13

10.5

UX06
UX06-D con regulador / with dimmer
TABLERO MARINO / PLYWOOD
Un color / One colour



• Incluye Difusor / Diffuser included

→ G5 - Max. 2x24 W



vento Pg. 54, 55

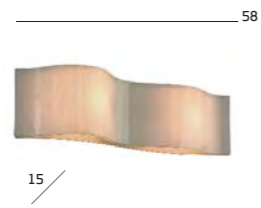

58

15

15

VN06
OPCIONES DE VIDRIO / GLASS OPTIONS
Un color / One colour



→ GU9 - Max. 2x9 W
→ G9 ECO - Max. 2x42 W (Philips)
→ G9 ECO - Max. 2x33 W (Osram)



ventopop

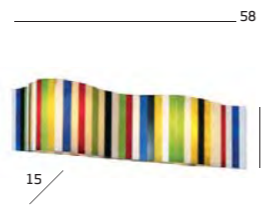

58

15

15

VN06POP
OPCIONES DE VIDRIO / GLASS OPTIONS
Combinación POP / POP combination



→ GU9 - Max. 2x9 W
→ G9 ECO - Max. 2x42 W (Philips)
→ G9 ECO - Max. 2x33 W (Osram)



arturo alvarez



Con toma de tierra
With ground devices



Doble aislamiento y/o
aislamiento reforzado en
cada parte y sin toma de
tierra.
Double insulation and/
or reinforced insulation
in every part and without
ground devices.



Aparato no adaptado
para la instalación en
superficies normalmente
inflamables.
The device is not suitable
for installation on normally
inflammable surface.



Premio otorgado
por The Chicago
Athenaeum: Museo de
Arquitectura y Diseño.
As awarded by The
Chicago Athenaeum:
Museum of Architecture
and Design.



Premio otorgado
por Design Zentrum
Nordrhein Westfalen.
As awarded by the
Design Zentrum
Nordrhein Westfalen.

Los productos de este catálogo son reproducciones fotográficas impresas. Es posible que el color de las imágenes varíe ligeramente con respecto al color real.

The products in this catalogue are printed photographic reproductions. The colour of the pictures may differ slightly from the real colour.

Todas nuestras luminarias están hechas íntegramente a mano en España.

All our light fittings are totally handmade in Spain.

Las diferencias entre ellas y en los vidrios convierten a cada lámpara en única.

The differences found in our lamps and in the glasses with which they are made, make them unique.

CE Todas las luminarias están homologadas y cumplen con la normativa CE.

CE All our fittings are legally approved and in accordance with the European Mark CE.

Manteniendo las características básicas de los diseños, arturo alvarez se reserva el derecho a realizar las modificaciones que considere oportunas con el fin de mejorarlos.

While maintaining the basic characteristics of the product, arturo alvarez reserves the right to make modifications at any time with the sole aim of improvement.

Los componentes electrónicos tienen garantía por 2 años.

Electric components have a two-year guarantee.

créditos

© 2010 Calor Color S.L.
Todos los derechos reservados

- Depósito legal: **C 502-2010**
- Realización y producción: **arturo alvarez**
- Impresión: **Litonor**

credits

© 2010 Calor Color S.L.
All rights reserved

- Legal deposit: **C 502-2010**
- Achievement and production: **arturo alvarez**
- Printing: **Litonor**