

a n n i v e r s a r y

ARKOSLIGHT®

light & life
desde 1984

ARKOS LIGHT[®]



Oscaluz® SL

Oscaluz® SL
ILUMINACION

Oscaluz®
ILUMINACION

OSCALUZ
ILUMINACION

 OSCALUZ | SL

O-ARKOS LIGHT S.L.

ARKOS LIGHT S.L.



ANIVERSARIO
DE ARKOSLIGHT
ARKOSLIGHT'S 30th ANNIVERSARY



1



2



3

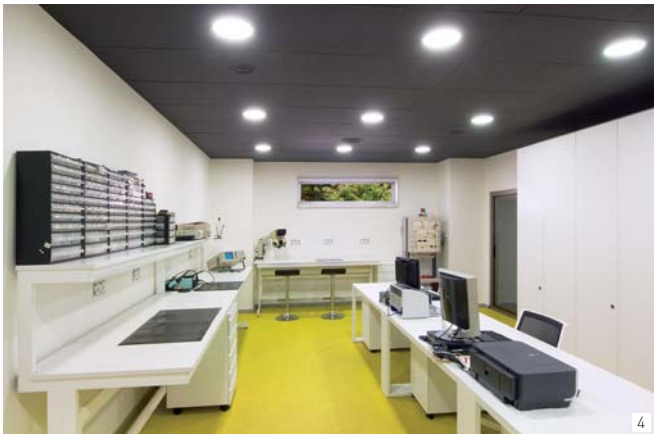

4

1. Investigación y Desarrollo
Research and Development
Recherche et développement
Ricerca e Sviluppo
Forschung und Entwicklung
2. Sala de Exposición
Showroom
Hall d'exposition
Showroom
Ausstellungsraum
3. Control de Producción
Production Control
Suivi de la production
Controllo di produzione
Produktionskontrolle
4. Laboratorio técnico
Technical laboratory
Laboratoire technique
Laboratorio tecnico
Technisches Labor
5. Sala de ensayos lumínicos
Light test chamber
Salle d'essais lumineux
Sala di prova di illuminazione
Raum für Lichtexperimente



30 ANIVERSARIO ARKOSLIGHT

Podríamos decir muchas cosas, pero solo vamos a decir una, GRACIAS a todos por acompañarnos durante 30 años. Arkoslight desde 1984.

ARKOSLIGHT'S 30th ANNIVERSARY

There are many things we could say at this point, but we will just say the most significant. THANKS to everyone for accompanying us along these past 30 years. Arkoslight, since 1984.

30^{ème} ANNIVERSAIRE ARKOSLIGHT

Il y aurait beaucoup à dire mais nous allons simplement dire, MERCI à tous ceux qui sont à nos côtés depuis 30 ans. Arkoslight depuis 1984.

30° ANNIVERSARIO DI ARKOSLIGHT

Potremmo dire molte cose, ma vogliamo semplicemente RINGRAZIARE tutti coloro che ci sono stati vicini per 30 anni. Arkoslight, dal 1984.

Dreißigjähriges Jubiläum Arkoslight

Man könnte an dieser Stelle Vieles sagen, wir aber sagen allem Voran eines! DANK an alle, die uns in diesen 30 Jahren begleitet haben. Arkoslight seit 1984.



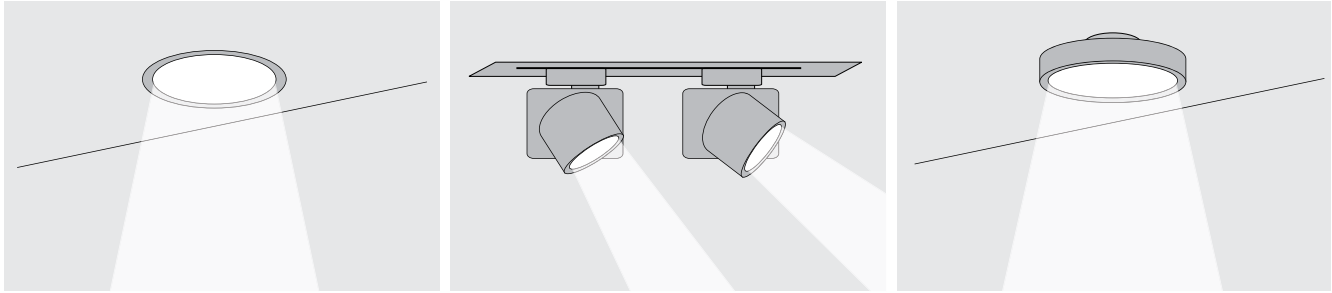

www.arkoslight.com

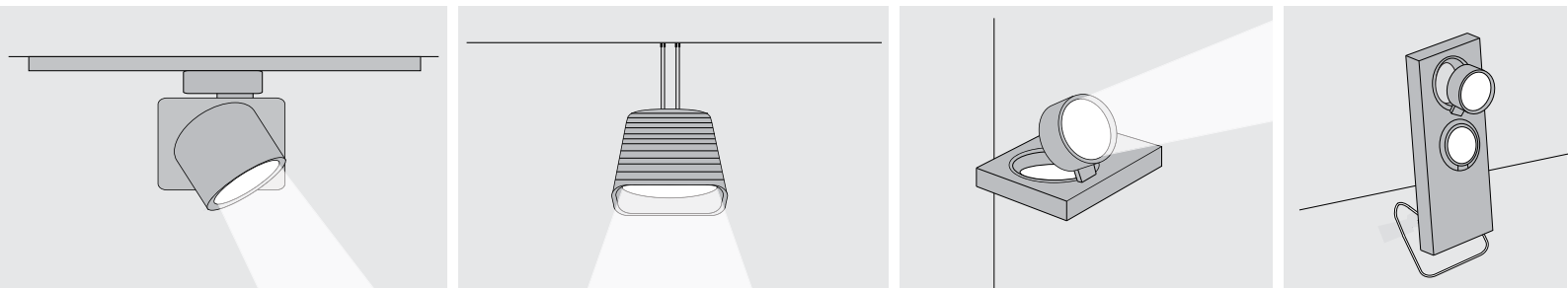

Arkoslight presenta su nueva página web en la cual ofrece filtros de búsqueda que permiten localizar cualquier producto de forma rápida y eficaz, con toda la información necesaria y actualizada. Con una estética minimalista y elegante, cuenta con un diseño capaz de adaptarse a cualquier dispositivo desde el que se acceda para facilitar al usuario una navegación más cómoda. Además, destaca el detalle y el diseño de los productos a través de fotografías y galerías de imágenes de gran presencia.

Arkoslight presents its new elegant and minimalist website. By using a responsive web design, the page adapts to any device it is accessed from and allows the user to navigate in any case in a very easy and comfortable manner.

The new website furthermore disposes of search filters which ensure that any product can be found quickly and efficiently, with all its corresponding relevant and up to date information. In addition, the new website highlights the details and design of the products with imposing photos and picture galleries.

Arkoslight présente son nouveau site Internet autour d'une esthétique minimaliste et élégante. Son design est responsive, il peut s'adapter à n'importe quel système d'accès pour que l'utilisateur puisse naviguer de façon confortable.

Le nouveau site propose une recherche avancée qui permet d'identifier rapidement et efficacement n'importe quel produit mais aussi toutes les informations nécessaires, celles-ci sont régulièrement mises à jour.

En outre, le nouveau portail insiste sur le sens du détail et le design des produits, les photos et galeries d'images sont largement présentes.

Arkoslight presenta la sua nuova pagina web dal look minimalista ed elegante. Il design intuitivo si adatta a qualsiasi dispositivo d'accesso ed offre all'utente un'esperienza di navigazione semplificata.

Il nuovo sito web offre filtri di ricerca che permettono di individuare qualsiasi prodotto in maniera rapida ed efficace e con tutte le informazioni necessarie ed aggiornate.

Inoltre, il nuovo sito web evidenzia i prodotti e i relativi dettagli tramite fotografie e gallerie d'immagini di grande impatto visivo.

Arkoslight präsentiert seine neue Webseite, elegant und übersichtlich. Mit einer adaptiven Konzeption, ist sie fähig, sich an alle Geräte, von denen auf sie zugegriffen wird, jeweils so vom Format her anzupassen, dass dem Benutzer jederzeit ein bequemes Surfen auf der Seite möglich ist.

Die neue Seite bietet weiters Suchfilter, mit denen man jedes Produkt schnell und effizient und finden kann, und umgehend zu allen notwendigen und aktuellen Informationen geführt wird.

Darüber hinaus hebt die neue Webseite Details und Design der Produkte mittels aussagekräftiger Fotografien bzw. Bildergalerien besonders hervor.

SOCIAL NETWORKS & VIDEOS

Arkoslight está presente en las redes sociales para fomentar la comunicación y la interacción con arquitectos, interioristas, decoradores, lighting designers, profesionales de la iluminación, clientes y proveedores.

A través de sus perfiles en Facebook, Twitter, LinkedIn, Google+ y Pinterest, ofrece información sobre la actualidad de la empresa y contenidos de interés acerca del sector de la iluminación, el diseño y la arquitectura. Además, y como parte de dicho contenido, pone a disposición del público, distintos vídeos de introducción, explicación y presentación de productos y novedades. Todo ello, con el objetivo de dar a conocer el interior de una empresa que cumple 30 años, y que está dispuesta a seguir iluminando.

Arkoslight is present on social networks in order to invigorate communication and interaction with architects, interior designers, decorators, lighting designers, lighting experts, customers and suppliers.

Via profiles on Facebook, Twitter, LinkedIn, Google+ and Pinterest, Arkoslight offers news about the current activities of the company, as well as content of interest concerning the lighting industry, design and architecture. Furthermore, and as part of this content, are publicly provided plenty of videos to introduce, explain and present both, existing and new products. All this with the purpose to show the marrow of a company that celebrates its 30th anniversary and which endeavors to keep on shining bright.

Arkoslight est présente sur Facebook, Twitter, LinkedIn, Google+ et Pinterest, les réseaux sociaux les plus importants pour favoriser la communication et l'interaction avec les architectes, architectes d'intérieur, décorateurs, designers d'éclairage, professionnels de l'éclairage, clients et fournisseurs. Par le biais de ses profils sur, Arkoslight communique autour

de l'actualité de l'entreprise et met en ligne des contenus intéressants pour le secteur de l'éclairage, le design et l'architecture. Parmi les contenus mis à disposition du public par Arkoslight, différentes vidéos de présentation et descriptifs des produits et nouveautés. Le seul objectif est de dévoiler la vie interne d'une entreprise qui fête ses trente ans et qui est prête à continuer à éclairer le monde.

La presenza di Arkoslight sui social network favorisce la comunicazione e l'interazione con architetti, interior designer, decoratori, lighting designers, tecnici dell'illuminazione, clienti e fornitori.

I profili Arkoslight su Facebook, Twitter, LinkedIn, Google+ e Pinterest, offrono informazioni, notizie aziendali e novità relative ai settori dell'illuminazione, del design e dell'architettura. Inoltre, l'azienda mette a disposizione del pubblico numerosi video introduttivi, tutorial, presentazioni di prodotti e novità. Tutto questo al fine di permettere una conoscenza approfondita di un'impresa con esperienza trentennale e con tanta voglia di continuare ad illuminare.

Arkoslight ist in allen relevanten sozialen Netzwerken präsent, um die Kommunikation und Interaktion mit Architekten, Innenarchitekten, Dekorateurs, Lichtdesignern, Beleuchtungsprofis, Kunden und Lieferanten zu fördern. Über seine Profile auf Facebook, Twitter, LinkedIn, Google+ und Pinterest, bietet Arkoslight aktuelle Informationen über das Unternehmen, sowie interessante Inhalte über die Beleuchtungsbranche, Design und Architektur. Darüberhinaus werden der Öffentlichkeit Präsentations-Videos zur Einführung und Erläuterung von Produkten und Neuigkeiten bereit gestellt. All dies mit dem Ziel, das Unternehmen, welches in Kürze sein dreißigjähriges Jubiläum feiert, weiter bekannt zu machen.





LIGHTING PROJECTS

Arkoslight ofrece a sus clientes la posibilidad de realizar estudios lumínicos para sus proyectos de diseño, interiorismo y arquitectura. Nuestro departamento técnico le ofrece la información necesaria para conocer la mejor distribución, intensidad, eficiencia, flujo lumínico y le asesora en la elección de la tipología de producto óptima para su proyecto.

Arkoslight offers its clients the chance to have light studies carried out for their design, interior design and architecture projects. Our technical department can provide the information you need to create the best possible light distribution, intensity, efficiency and flow, offering professional advice on the type of product that best suits your project.

Arkoslight offre à ses clients la possibilité de réaliser des études d'illumination pour leurs projets de conception, d'architecture et d'architecture intérieure. Notre département technique vous offre l'information nécessaire pour connaître la meilleure distribution, intensité, efficacité, flux d'illumination et vous conseille sur le choix de la typologie de produit optimum pour votre projet.

Arkoslight offre ai suoi clienti la possibilità di realizzare studi luminosi per i loro progetti di design, interior design e architettura. La nostra divisione tecnica fornisce le informazioni necessarie per una migliore distribuzione, intensità, efficienza, flusso luminoso e vi consiglia come scegliere il miglior tipo di prodotto per il vostro progetto.

Arkoslight bietet seinen Kunden die Möglichkeit, an Lichtwerkstätten für dessen Projekte in Sachen Gestaltung, Raumgestaltung und Architektur teilzunehmen. Unsere technische Abteilung bietet Ihnen alle notwendigen Informationen, um die beste Verteilung, Intensität, Effizienz sowie den besten Lichtstrom kennen zu lernen und berät Sie gerne bei der Auswahl der Typologie des für Ihr Projekt optimalen Produktes.



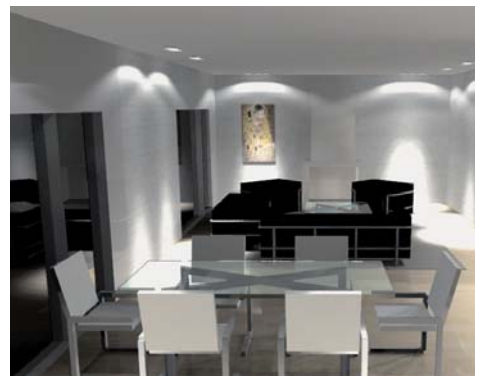
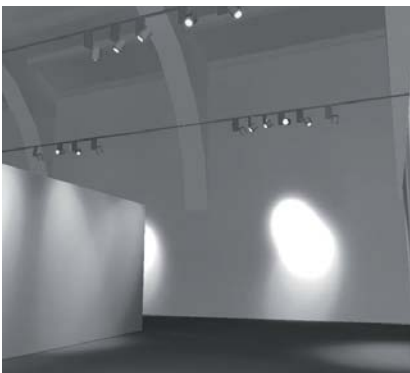



CEILING RECESSED



STRAM 018



DROP 022



DROP MINI 026



MIX 028



MIX MINI 032



LEX ECO 034



QUAD 042



QUAD GLASS 046



MADISON 048



FOX 050



FOX MINI 056



MAX 058



MAX MINI 066



ARKITECT 068



KISS 076



DRY 078



TR1 080



TR2 082



DOT 084



WIN 088



GAP 092



MEC 100



EYE 106



BATH 110



GIRO 114



DECO 116



SECRET 118



CIBER 126



BASIC 130



FUNGHI 136



OFFICE 142



ARKOS T5 146



TWIST 152



LOOK 160



LOOK TRIMLESS 166



ORBITAL 172



ORBITAL TRIMLESS 182

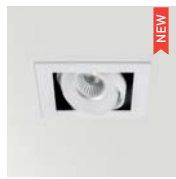

ORBITAL MINI 190



ARKOS 196



ARKOS TRIMLESS 202



HIDDEN 208



POINT 220 214



TRACK LIGHTS



ZEN 224



ZEN TUBE TRACK 238



KON 240



MOVE 248



PROFILES



SLIMGOT 262



FORTY 266



PROFILE 035 272



PROFILE 040 280



PROFILE 140 298



PROFILE 220 316

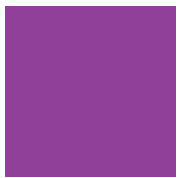

SURFACE & SUSPENDED



SKY 332



ORBITAL SURFACE 336



ZEN TUBE 344



KON SURFACE 348



MOVE SURFACE 352



SURF 358



ZOOM 360



SPIDER 376



BRIGIT SUSPENSION 394



WALL LIGHTS



AURAE 404



SLIM 408



LED WALL LIGHTS 410



ZOOM WALL 414



P220 WALL 418



COIN 422



VITUBER 422



FLOOR

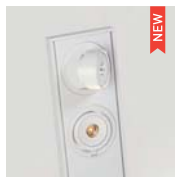

P220 FLOOR 428



BRIGIT 434



STAR 438



ACCESSORIES 450



DESIGN PLUS
2012 AWARD



summary ^{ARKOS LIGHT®}



ceiling
recessed

CEILING RECESSED



STRAM 018



DROP 022



DROP MINI 026



MIX 028



MIX MINI 032

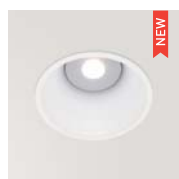

LEX ECO 034



QUAD 042



QUAD GLASS 046



MADISON 048



FOX 050



FOX MINI 056



MAX 058



MAX MINI 066



ARKITECT 068



KISS 076



DRY 078



TR1 080



TR2 082



DOT 084



WIN 088

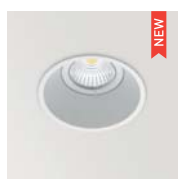

GAP 092

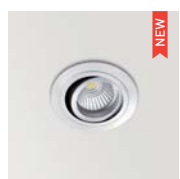

MEC 100



EYE 106

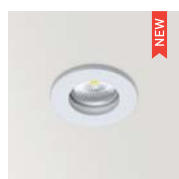

BATH 110



GIRO 114



DECO 116



SECRET 118



CIBER 126



BASIC 130



FUNGHI 136



OFFICE 142



ARKOS T5 146



TWIST 152



LOOK 160

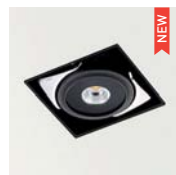

LOOK TRIMLESS 166



ORBITAL 172

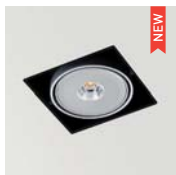

ORBITAL TRIMLESS 182

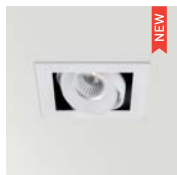

ORBITAL MINI 190



ARKOS 196



ARKOS TRIMLESS 202



HIDDEN 208



POINT 220 214

NEW

STRAM



		W	K	mA	Lm	%Eff
STRAM 1	A197-01- ☉ -1- WT	15W	3000K	700	1450	84%
	A197-01- ☉ -2- WT	15W	4000K	700	1550	84%
STRAM 2	A197-02- ☉ -1- WT	20W	3000K	700	1900	84%
	A197-02- ☉ -2- WT	20W	4000K	700	2000	84%
STRAM 3	A197-03- ☉ -1- WT	24W	3000K	700	2300	84%
	A197-03- ☉ -2- WT	24W	4000K	700	2400	84%
STRAM 4	A197-04- ☉ -1- WT	36W	3000K	1050	3450	84%
	A197-04- ☉ -2- WT	36W	4000K	1050	3600	84%

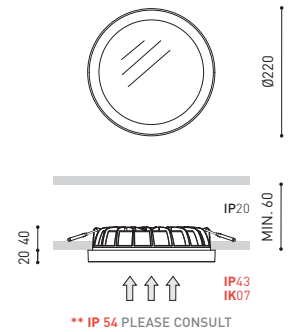

☉ OPTIONS*

1	No DIM
2	DIM Push
3	DIM 1-10V
4	DIM DALI



COLOUR | WT | MATERIAL | AL | PMMA |

» 452 | » 468



Photography: Héctor Santos - Diez - Bismages - www.bismages.com

STRAM PRISMATIC



		W	K	mA	Lm	%Eff
STRAM Prismatic 1	A198-01- ☉ -1- WT	15W	3000K	700	1450	84%
	A198-01- ☉ -2- WT	15W	4000K	700	1550	84%
STRAM Prismatic 2	A198-02- ☉ -1- WT	20W	3000K	700	1900	84%
	A198-02- ☉ -2- WT	20W	4000K	700	2000	84%
STRAM Prismatic 3	A198-03- ☉ -1- WT	24W	3000K	700	2300	84%
	A198-03- ☉ -2- WT	24W	4000K	700	2400	84%
STRAM Prismatic 4	A198-04- ☉ -1- WT	36W	3000K	1050	3450	84%
	A198-04- ☉ -2- WT	36W	4000K	1050	3600	84%

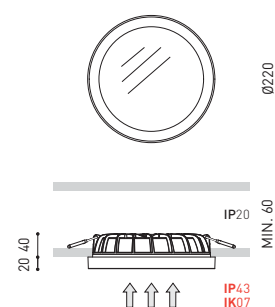

LED | UPDATE | 220V/240V 50/60 Hz | CE | IP43 | IK07 | CRI>80 | OPTIONS* | CONNEX | INCL I ELEC | EU | LED DRIVER | Ø205 | 1

☉ OPTIONS*

1	No DIM
2	DIM Push
3	DIM 1-10V
4	DIM DALI



COLOUR | WT | MATERIAL | AL | PMMA |

i » 452 | Q » 468



NEW

DROP



		W	K	mA	Lm	%Eff
DROP 1	A193-01- ☉ -1- WT	15W	3000K	700	1450	84%
	A193-01- ☉ -2- WT	15W	4000K	700	1550	84%
DROP 2	A193-02- ☉ -1- WT	20W	3000K	700	1900	84%
	A193-02- ☉ -2- WT	20W	4000K	700	2000	84%
DROP 3	A193-03- ☉ -1- WT	24W	3000K	700	2300	84%
	A193-03- ☉ -2- WT	24W	4000K	700	2400	84%
DROP 4	A193-04- ☉ -1- WT	36W	3000K	1050	3450	84%
	A193-04- ☉ -2- WT	36W	4000K	1050	3600	84%

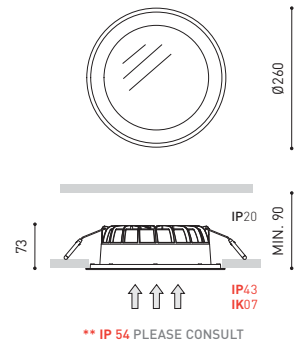

☉	OPTIONS*
1	No DIM
2	DIM Push
3	DIM 1-10V
4	DIM DALI



COLOUR | WT ☐ | MATERIAL | AL | PMMA |

» 452 | » 468



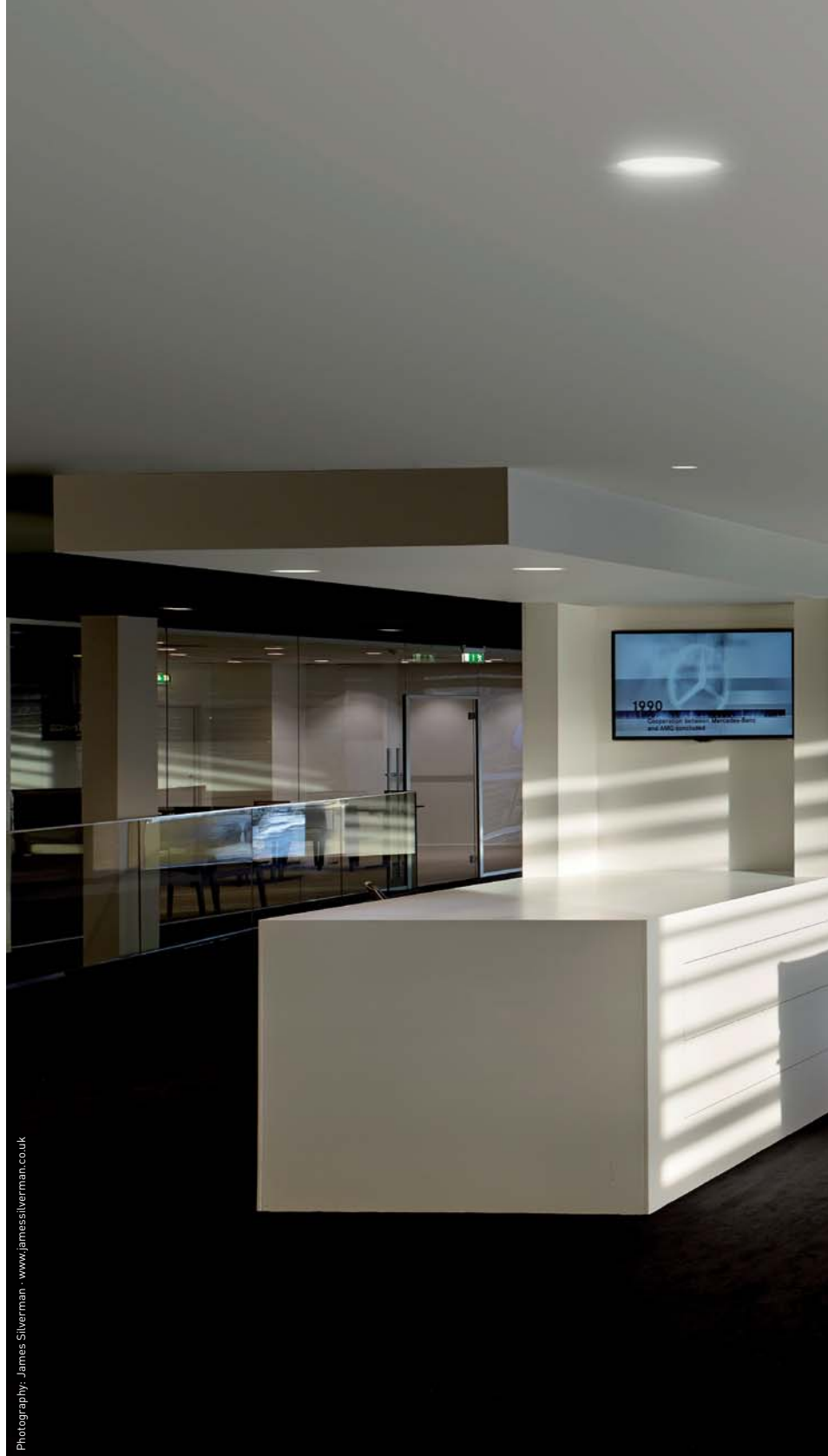

Photography: James Silverman · www.jamessilverman.co.uk



NEW

DROP MINI



				W	K	mA	Lm	%Eff
DROP MINI 1	A194-01-	1 -1-	WT	6,5W	3000K	700	600	82%
	A194-01-	1 -2-	WT	6,5W	4000K	700	650	82%
DROP MINI 2	A194-02-	⊙ -1-	WT	9W	3000K	700	850	82%
	A194-02-	⊙ -2-	WT	9W	4000K	700	900	82%

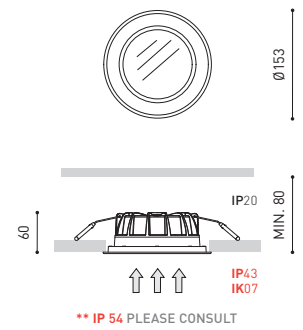

⊙ OPTIONS*

1	No DIM
2	DIM Push
3	DIM 1-10V
4	DIM DALI



COLOUR | WT | MATERIAL | AL | PMMA |

» 452 | » 468



Photography: James Silverman - www.jamesilverman.co.uk

MIX



		W	K	mA	Lm	%Eff
MIX 1	A187-01- Ⓞ -1- W Z	15W	3000K	700	1450	84%
	A187-01- Ⓞ -2- W Z	15W	4000K	700	1550	84%
MIX 2	A187-02- Ⓞ -1- W Z	20W	3000K	700	1900	84%
	A187-02- Ⓞ -2- W Z	20W	4000K	700	2000	84%
MIX 3	A187-03- Ⓞ -1- W Z	24W	3000K	700	2300	84%
	A187-03- Ⓞ -2- W Z	24W	4000K	700	2400	84%
MIX 4	A187-04- Ⓞ -1- W Z	36W	3000K	1050	3450	84%
	A187-04- Ⓞ -2- W Z	36W	4000K	1050	3600	84%

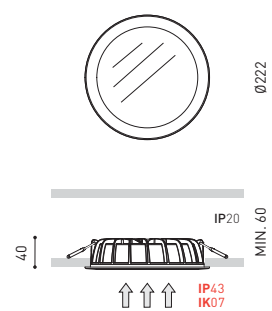

		W	K	mA	Lm	%Eff
MIX IP54 1	A187-11- Ⓞ -1- W Z	15W	3000K	700	1450	84%
	A187-11- Ⓞ -2- W Z	15W	4000K	700	1550	84%
MIX IP54 2	A187-12- Ⓞ -1- W Z	20W	3000K	700	1900	84%
	A187-12- Ⓞ -2- W Z	20W	4000K	700	2000	84%
MIX IP54 3	A187-13- Ⓞ -1- W Z	24W	3000K	700	2300	84%
	A187-13- Ⓞ -2- W Z	24W	4000K	700	2400	84%
MIX IP54 4	A187-14- Ⓞ -1- W Z	36W	3000K	1050	3450	84%
	A187-14- Ⓞ -2- W Z	36W	4000K	1050	3600	84%

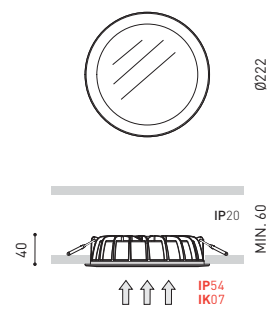

Ⓞ OPTIONS*

1	No DIM
2	DIM Push
3	DIM 1-10V
4	DIM DALI



COLOUR | W □ | Z ■ | MATERIAL | AL | PMMA |

>> 452 | >> 468



Photography: Joao Morgado - Fotografia de Arquitectura - www.photo.joaomorgado.com





NEW

MIX MINI



		W	K	mA	Lm	%Eff
MIX MINI 1	A188-01- 1 -1- W Z	6,5W	3000K	700	600	82%
	A188-01- 1 -2- W Z	6,5W	4000K	700	650	82%
MIX MINI 2	A188-02- ② -1- W Z	9W	3000K	700	850	82%
	A188-02- ② -2- W Z	9W	4000K	700	900	82%

50/60 Hz

		W	K	mA	Lm	%Eff
MIX MINI IP54 1	A188-11- 1 -1- W Z	6,5W	3000K	700	600	82%
	A188-11- 1 -2- W Z	6,5W	4000K	700	650	82%
MIX MINI IP54 2	A188-12- ② -1- W Z	9W	3000K	700	850	82%
	A188-12- ② -2- W Z	9W	4000K	700	900	82%

50/60 Hz

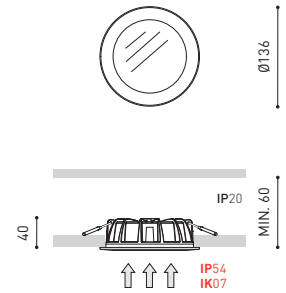
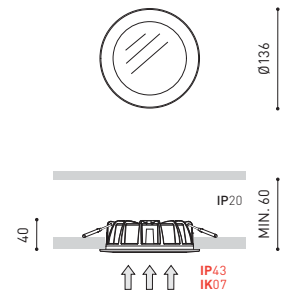

②	OPTIONS*
1	No DIM
2	DIM Push
3	DIM 1-10V
4	DIM DALI



COLOUR | W □ | Z ■ | MATERIAL | AL | PMMA |

» 452 | » 468



Photography: Héctor Santos - Diez - Bisimages - www.bisimages.com

NEW

LEX ECO



DESIGN PLUS
2012 AWARD

		W	K	mA	Lm	%Eff
LEX ECO 1 PUSH 1/10V DALI	A070- 00 -01- W	12W	3000K	350	1350	70%
	A070- 00 -02- W	12W	4000K	350	1450	70%
	A070- 00 -05- W	12W	3000K	350	1350	70%
	A070- 00 -06- W	12W	4000K	350	1450	70%
	A070- 00 -09- W	12W	3000K	350	1350	70%
	A070- 00 -10- W	12W	4000K	350	1450	70%
	A070- 00 -13- W	12W	3000K	350	1350	70%
	A070- 00 -14- W	12W	4000K	350	1450	70%
LEX ECO 2 PUSH 1/10 DALI	A070- 00 -03- W	24,5W	3000K	700	2250	70%
	A070- 00 -04- W	24,5W	4000K	700	2350	70%
	A070- 00 -07- W	24,5W	3000K	700	2250	70%
	A070- 00 -08- W	24,5W	4000K	700	2350	70%
	A070- 00 -11- W	24,5W	3000K	700	2250	70%
	A070- 00 -12- W	24,5W	4000K	700	2350	70%
	A070- 00 -15- W	24,5W	3000K	700	2250	70%
	A070- 00 -16- W	24,5W	4000K	700	2350	70%

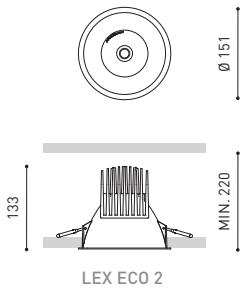
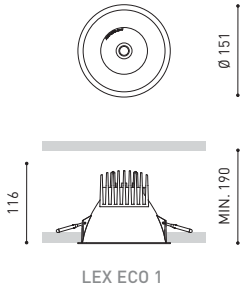

00	OPTIONS
01	LEX ECO
02	LEX ECO Blue



COLOUR | W □ | MATERIAL | AL | PC | *CRI>90 PLEASE CONSULT | » 452 | » 468

LEX ECO 205

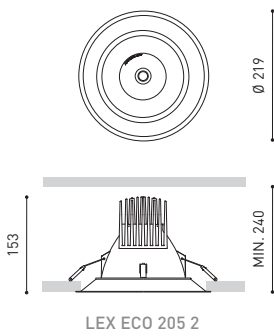
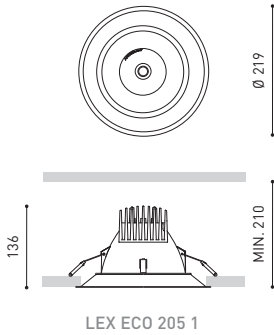

		W	K	mA	Lm	%Eff	
LEX ECO 205 1	A070- 00 -01- W	12W	3000K	350	1350	70%	
	A070- 00 -02- W	12W	4000K	350	1450	70%	
	PUSH	A070- 00 -05- W	12W	3000K	350	1350	70%
		A070- 00 -06- W	12W	4000K	350	1450	70%
	1/10V	A070- 00 -09- W	12W	3000K	350	1350	70%
		A070- 00 -10- W	12W	4000K	350	1450	70%
	DALI	A070- 00 -13- W	12W	3000K	350	1350	70%
		A070- 00 -14- W	12W	4000K	350	1450	70%
	LEX ECO 205 2	A070- 00 -03- W	24,5W	3000K	700	2250	70%
		A070- 00 -04- W	24,5W	4000K	700	2350	70%
PUSH		A070- 00 -07- W	24,5W	3000K	700	2250	70%
		A070- 00 -08- W	24,5W	4000K	700	2350	70%
1/10		A070- 00 -11- W	24,5W	3000K	700	2250	70%
		A070- 00 -12- W	24,5W	4000K	700	2350	70%
DALI		A070- 00 -15- W	24,5W	3000K	700	2250	70%
		A070- 00 -16- W	24,5W	4000K	700	2350	70%

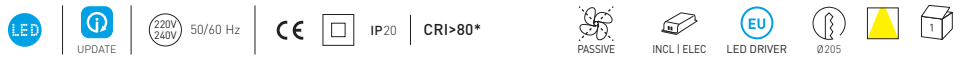

00	OPTIONS
03	LEX ECO 205
04	LEX ECO 205 Blue

LEX ECO 205 & LEX ECO 205 BLUE ON



LEX ECO 205 BLUE OFF



COLOUR | W □ | MATERIAL | AL | PC

*CRI>90 PLEASE CONSULT

» 452 | » 468



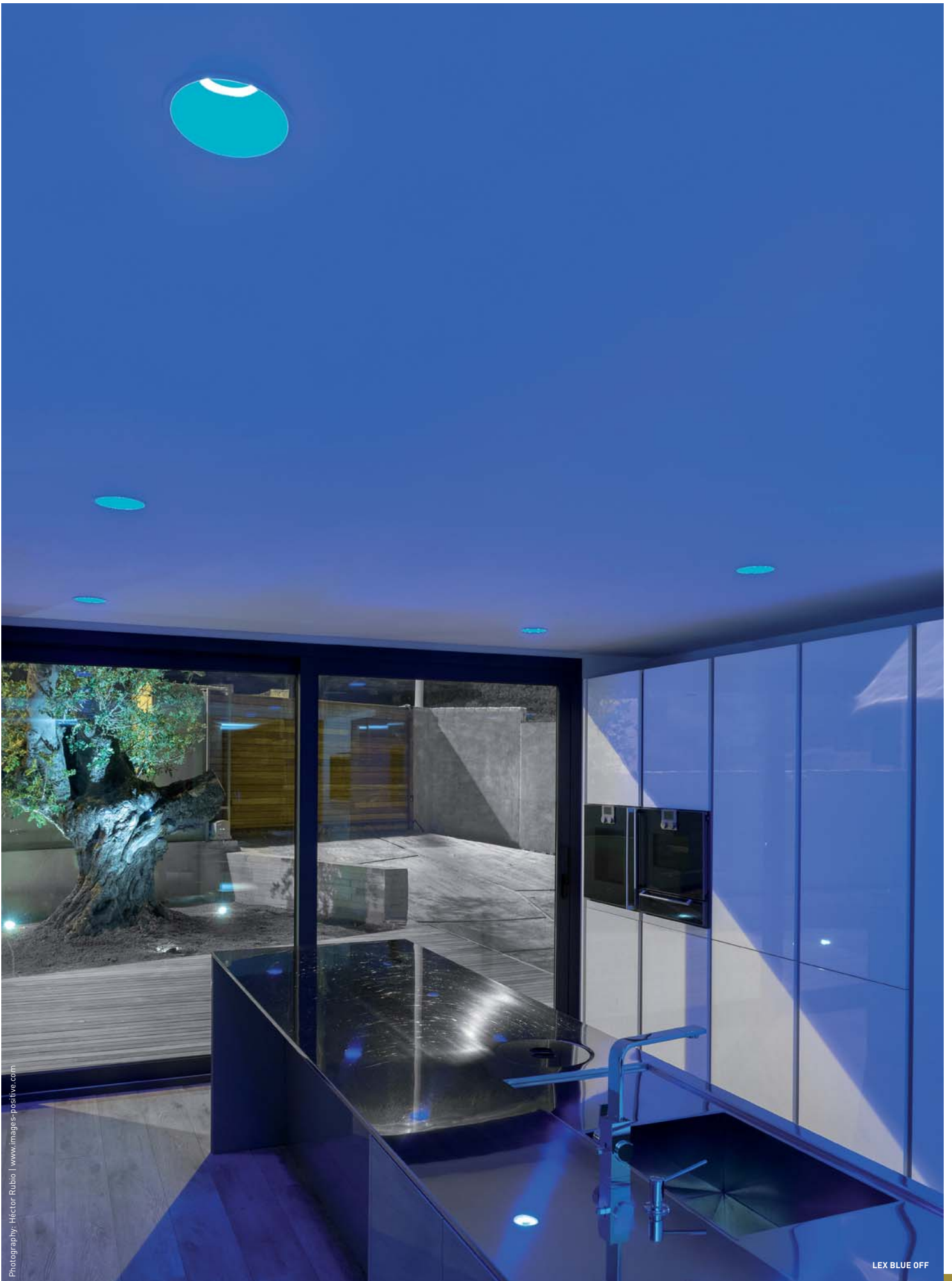



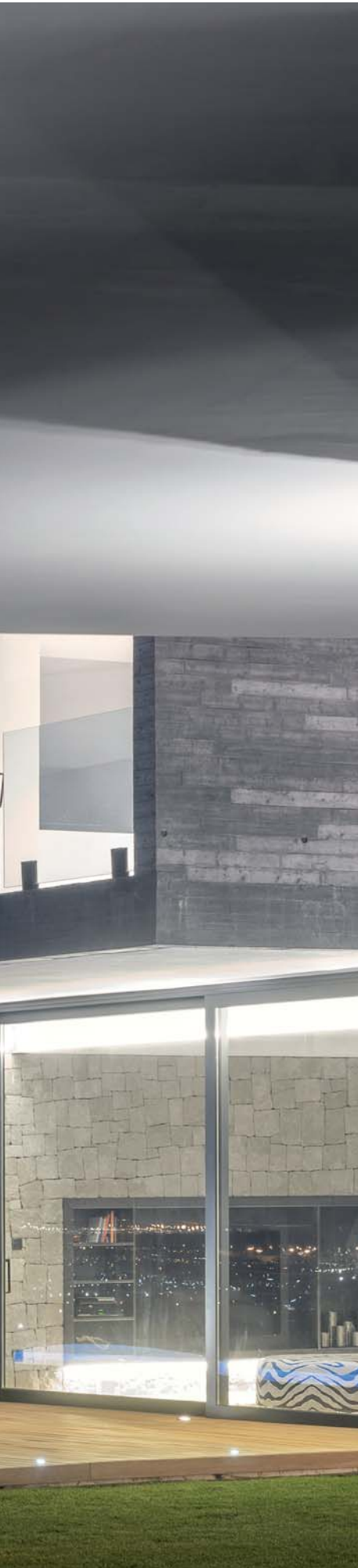

LEX ECO ASYMMETRIC



		W	K	mA	Lm	%Eff
LEX ECO Asymmetric 1 PUSH 1/10V DALI	A071- 00 -01- W	12W	3000K	350	1350	70%
	A071- 00 -02- W	12W	4000K	350	1450	70%
	A071- 00 -05- W	12W	3000K	350	1350	70%
	A071- 00 -06- W	12W	4000K	350	1450	70%
	A071- 00 -09- W	12W	3000K	350	1350	70%
	A071- 00 -10- W	12W	4000K	350	1450	70%
	A071- 00 -13- W	12W	3000K	350	1350	70%
	A071- 00 -14- W	12W	4000K	350	1450	70%
LEX ECO Asymmetric 2 PUSH 1/10V DALI	A071- 00 -03- W	24,5W	3000K	700	2250	70%
	A071- 00 -04- W	24,5W	4000K	700	2350	70%
	A071- 00 -07- W	24,5W	3000K	700	2250	70%
	A071- 00 -08- W	24,5W	4000K	700	2350	70%
	A071- 00 -11- W	24,5W	3000K	700	2250	70%
	A071- 00 -12- W	24,5W	4000K	700	2350	70%
	A071- 00 -15- W	24,5W	3000K	700	2250	70%
	A071- 00 -16- W	24,5W	4000K	700	2350	70%

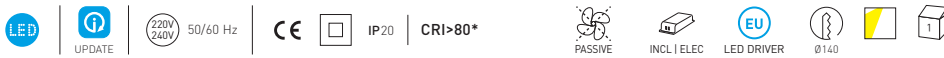
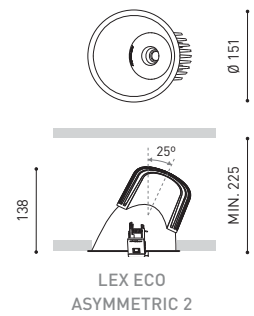
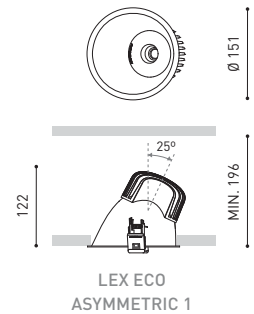

00	OPTIONS
01	LEX ECO Asymmetric
02	LEX ECO Asymmetric Blue



COLOUR | W | MATERIAL | AL | PC |

*CRI>90 PLEASE CONSULT >> 452 | >> 468

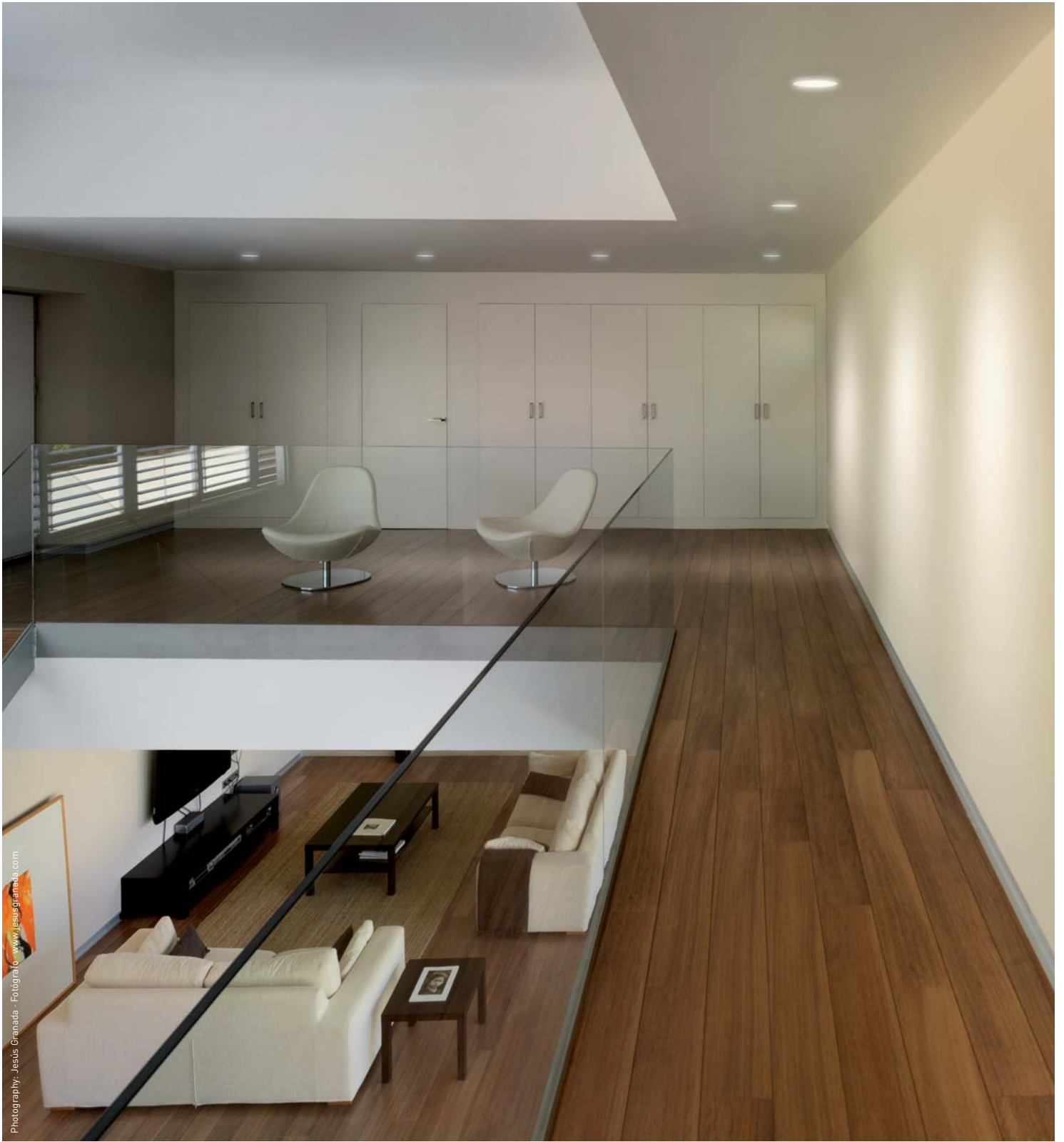

Photography: Jesús Granada - Fotógrafo - www.jesusgranada.com

NEW

QUAD

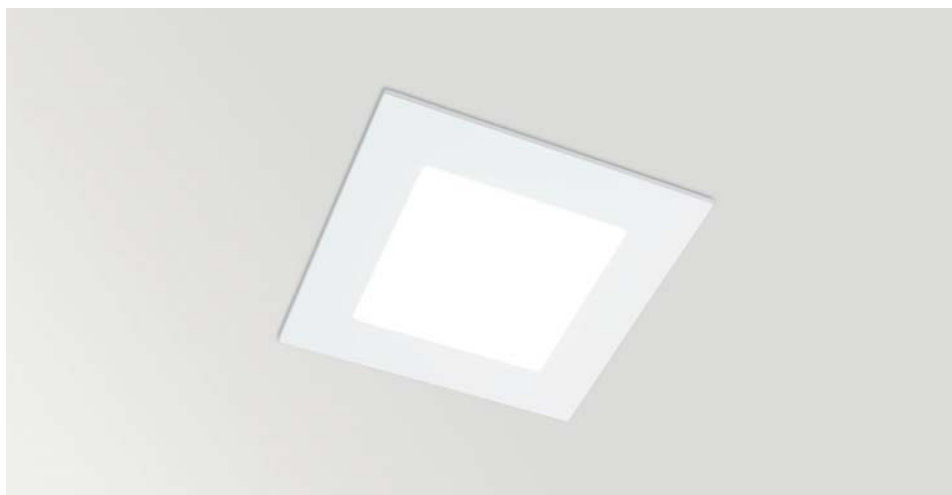

		W	K	mA	Lm	%Eff
QUAD 1	A189-01- Ⓞ -1- W Z	15W	3000K	700	1450	86%
	A189-01- Ⓞ -2- W Z	15W	4000K	700	1550	86%
QUAD 2	A189-02- Ⓞ -1- W Z	20W	3000K	700	1900	86%
	A189-02- Ⓞ -2- W Z	20W	4000K	700	2000	86%
QUAD 3	A189-03- Ⓞ -1- W Z	24W	3000K	700	2300	86%
	A189-03- Ⓞ -2- W Z	24W	4000K	700	2400	86%

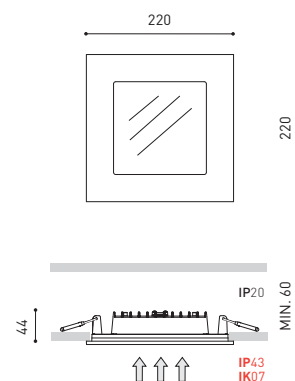

Ⓞ OPTIONS*

1	No DIM
2	DIM Push
3	DIM 1-10V
4	DIM DALI



COLOUR | W □ | Z ■ | MATERIAL | AL | PMMA |

» 452 | » 468



Photografía: David Frutos, Bismages, www.bismages.com



Photography: José Morgado - Fotografía de Arquitectura - www.fotojosemorgado.com



NEW

QUAD GLASS



		W	K	mA	Lm	%Eff
QUAD GLASS 1	A189-11- ∞ -1- W Z	15W	3000K	700	1450	75%
	A189-11- ∞ -2- W Z	15W	4000K	700	1550	75%
QUAD GLASS 2	A189-12- ∞ -1- W Z	20W	3000K	700	1900	75%
	A189-12- ∞ -2- W Z	20W	4000K	700	2000	75%
QUAD GLASS 3	A189-13- ∞ -1- W Z	24W	3000K	700	2300	75%
	A189-13- ∞ -2- W Z	24W	4000K	700	2400	75%

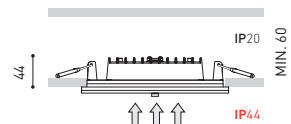
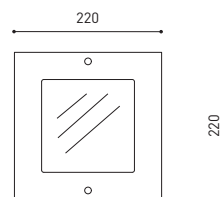

∞	OPTIONS*
1	No DIM
2	DIM Push
3	DIM 1-10V
4	DIM DALI



COLOUR | W □ | Z ■ | MATERIAL | AL | GLASS | PMMA |

» 452 | » 468

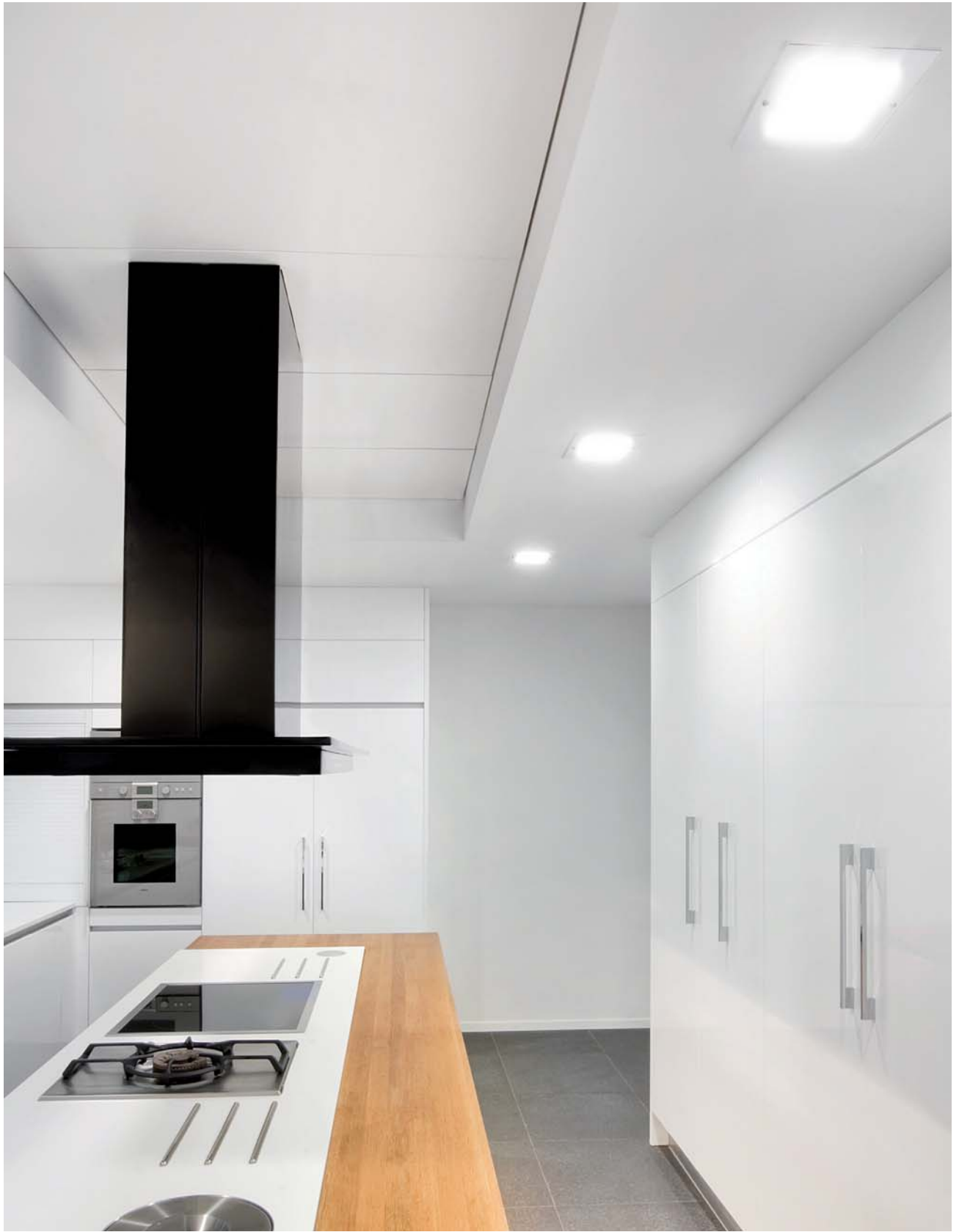

Vicente Navarro - Estudio de Interiorismo - www.vicentenavarro.es

NEW

MADISON



		W	K	mA	Lm	%Eff
MADISON 1	A190-01- Ⓞ -1- W Z	15W	3000K	700	1450	86%
	A190-01- Ⓞ -2- W Z	15W	4000K	700	1550	86%
MADISON 2	A190-02- Ⓞ -1- W Z	20W	3000K	700	1900	86%
	A190-02- Ⓞ -2- W Z	20W	4000K	700	2000	86%
MADISON 3	A190-03- Ⓞ -1- W Z	24W	3000K	700	2300	86%
	A190-03- Ⓞ -2- W Z	24W	4000K	700	2400	86%

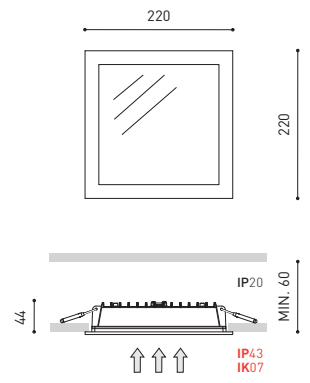

LED | UPDATE | 220V/240V 50/60 Hz | CE | IP43 | IK07 | CRI>80 | OPTIONS* | CONNEC | INCL I ELEC | LED DRIVER | 205 X 205 | EU | 205 X 205 | 1

Ⓞ	OPTIONS*
1	No DIM
2	DIM Push
3	DIM 1-10V
4	DIM DALI



COLOUR | W □ | Z ■ | MATERIAL | AL | PMMA |

i >> 452 | q >> 468



Photography: Joac Morgado - Fotografia de Arquitectura - www.photojoacmorgado.com

FOX



		⊕	W
FOX	4220-00-00- W Z	G24q-2	2 X 18W
	4221-00-00- W Z	G24q-3	2 X 26W



50/60 Hz



IP54

IK10

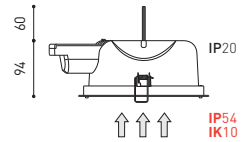
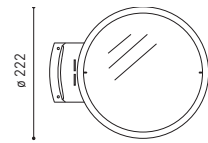

COLOUR | W □ | Z ■ |

MATERIAL | ○ PC | ○ PC-MATT | OPTIONAL ○ PC-TRANS |

ⓘ » 452



Photography: Héctor Santos - Díez - Bismages - www.bismages.com









Photography: David Frutos - Blisimages - www.blisimages.com

FOX MINI



FOX MINI	4230-00-00- W Z	TC-DEL	G24q-1	1 X 13W
	4231-00-00- W Z	TC-TEL	GX24q-2	1 X 18W
	4232-00-00- W Z	TC-TEL	GX24q-3	1 X 26W

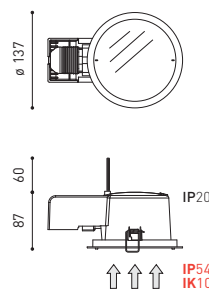

COLOUR | W □ | Z ■ | MATERIAL | PC | PC-MATT | OPTIONAL PC-TRANS |

ⓘ » 452

Photography: Diego Opazo - Project: Alfaro Hofmann | Fran Silvestre Arquitectos

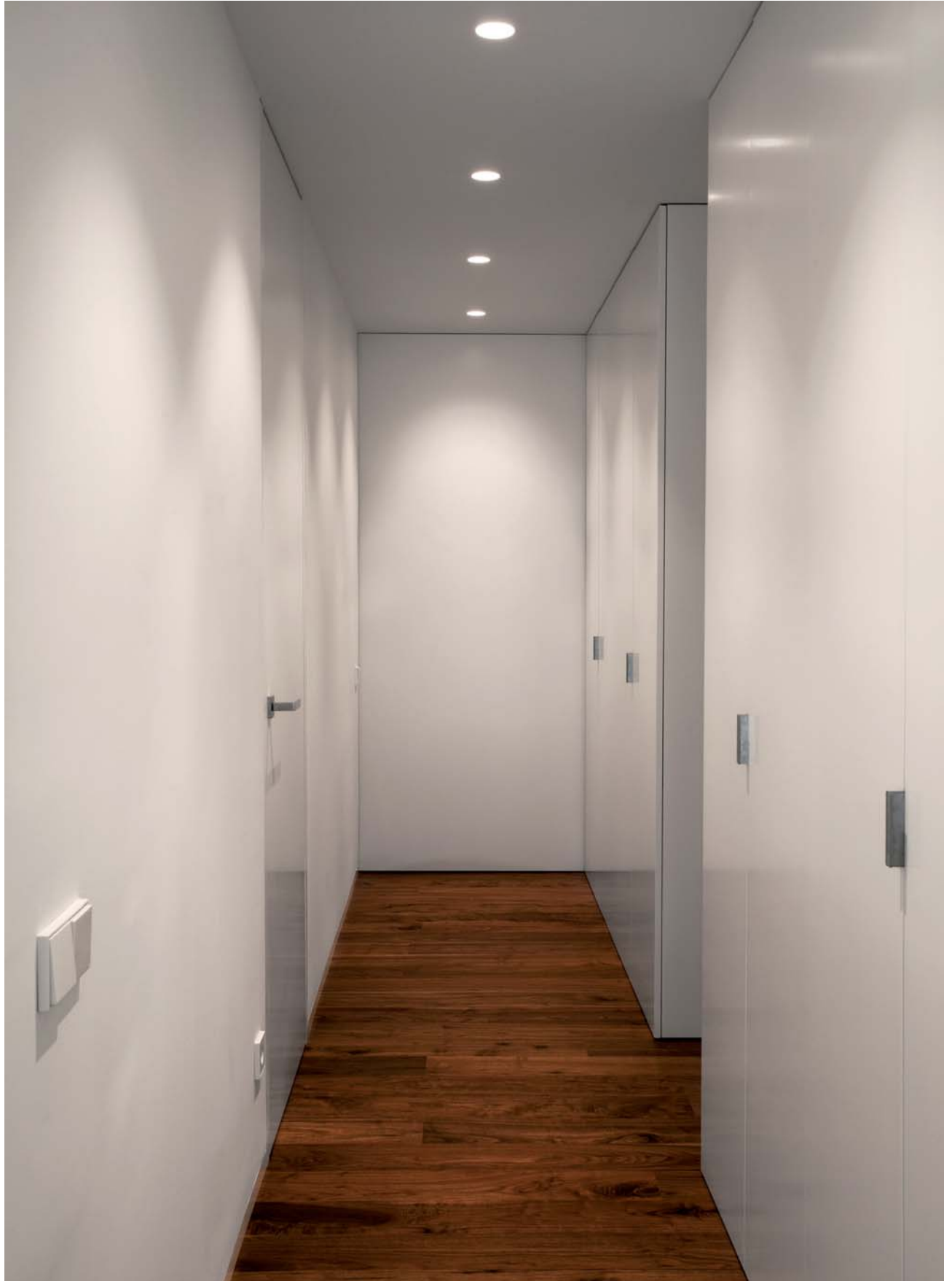

MAX



				⊕	W
MAX	4096-00-00-	B Z NS		G24q-2	1 X 18W
	4097-00-00-	B Z NS		G24q-2	2 X 18W
	4098-00-00-	B Z NS		G24q-3	1 X 26W
	4099-00-00-	B Z NS		G24q-3	2 X 26W
	4099-01-00-	B Z NS		G24q-3	2 X 26W
	4099-07-00-	B Z NS		G24q-3	2 X 26W

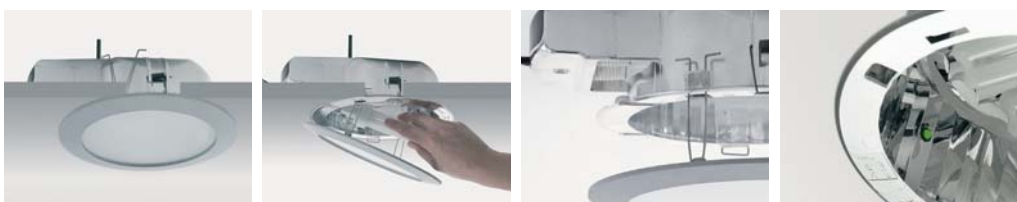
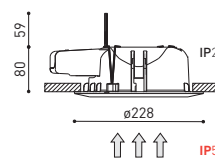

COLOUR | B □ | Z ■ | NS ■ | MATERIAL | AL | PC | GL-MATT | GL-TRANS OPTIONAL | >> 452



Photography: Héctor Santos-Díez | Bisimages - www.bisimages.com



Photography: Jesús Granada - Fotógrafo - www.jesusgranada.com

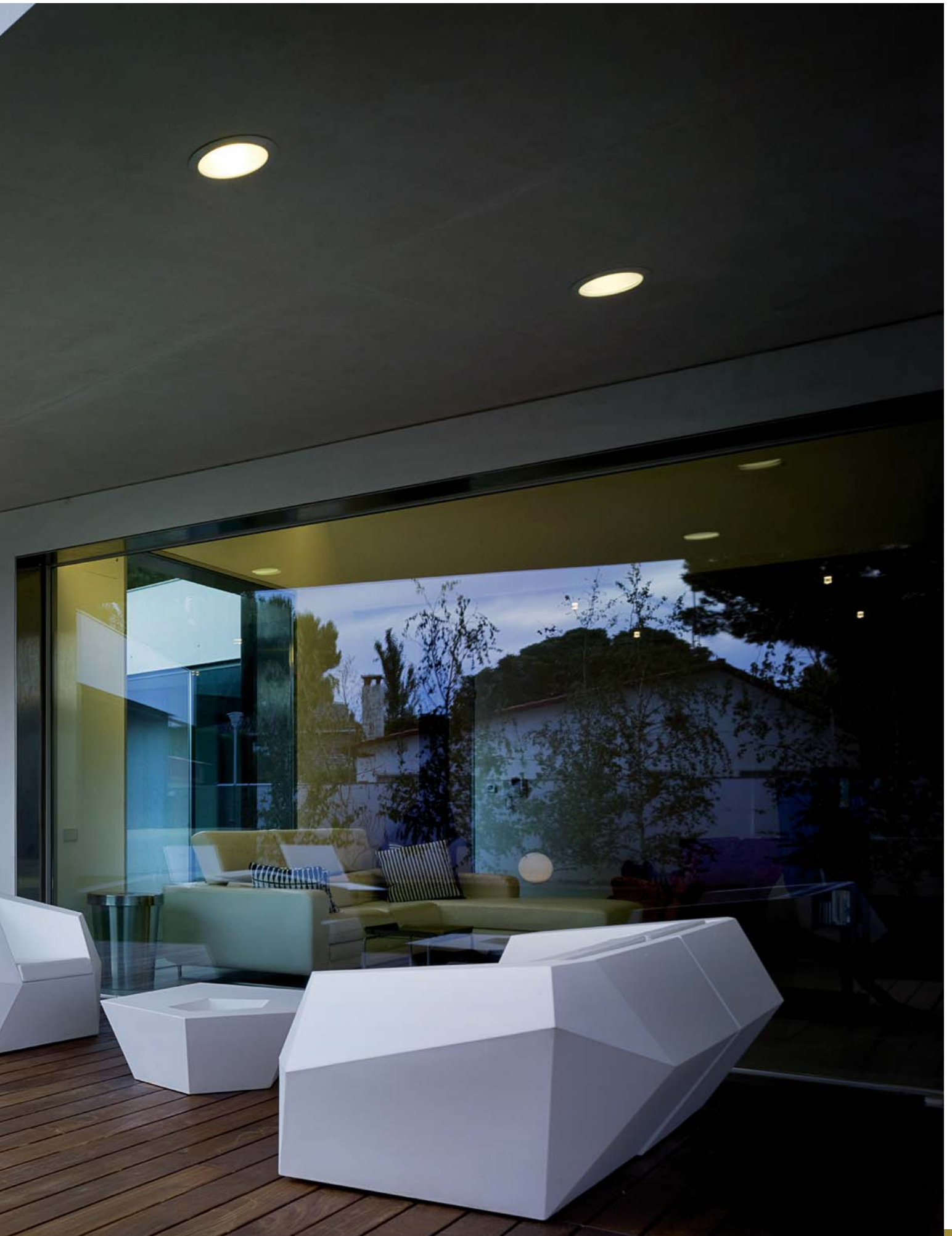



MAX LOUVER



					⊕	W
MAX LOUVER	4097-00-00-	LB	LZ	LS	G24q-2	2 X 18W
	4099-00-00-	LB	LZ	LS	G24q-3	2 X 26W
	4099-01-00-	LB	LZ	LS	G24q-3	2 X 26W
	4099-07-00-	LB	LZ	LS	G24q-3	2 X 26W



IP20



1-10V



EMERGENCY 3h



CONNEX



INCL. ELEC



Ø205

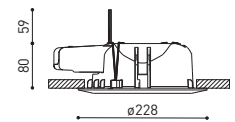

COLOUR | LB □ | LZ ■ | LS ■ | MATERIAL | AL | + PC

ⓘ » 452

MAX HIT



						W
MAX HIT-DE	4100-00-00-	B	Z	NS		70W
	4101-00-00-	B	Z	NS		150W

FOOD FILTER OPTIONS

	Bread	0700-05-01
	Meat	0700-05-02
	Fish	0700-05-03

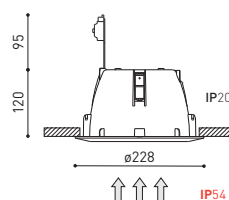

COLOUR | B | Z | NS | MATERIAL | AL | PPS | GL-MATT | » 452



Photography: Jesus Granada | Bisimages - www.bisimages.com



MAX MINI



MAX MINI	4081-00-00-	B	Z	NS	TC-DEL	G24q-1	1 X 13W
	4083-00-00-	B	Z	NS	TC-TEL	GX24q-2	1 X 18W
	4089-00-00-	B	Z	NS	TC-TEL	GX24q-3	1 X 26W

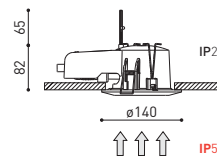







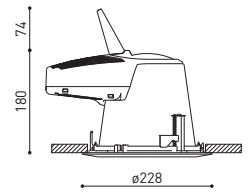

COLOUR | B □ | Z ■ | NS ■ | MATERIAL | AL | PC | GL-MATT |

i » 452



ARKITECT



						W
ARKITECT 230	3508-00-00-	W Z		TC-DEL	G24q-2	2 X 18W
	3510-00-00-	W Z		TC-DEL	G24q-3	2 X 26W
	3510-01-00-	W Z		TC-DEL	G24q-3	2 X 26W
	3510-07-00-	W Z		TC-DEL	G24q-3	2 X 26W
	3511-00-00-	W Z		TC-TEL	GX24q-3	2 X 32W
	3511-01-00-	W Z		TC-TEL	GX24q-3	2 X 32W
	3511-07-00-	W Z		TC-TEL	GX24q-3	2 X 32W
	3513-00-00-	W Z		TC-TEL	GX24q-4	2 X 42W
	3513-01-00-	W Z		TC-TEL	GX24q-4	2 X 42W
	3513-07-00-	W Z		TC-TEL	GX24q-4	2 X 42W
	3539-00-00-	W Z		TC-TEL	GX24q-3	1 X 32W
	3512-00-00-	W Z		TC-TEL	GX24q-4	1 X 42W

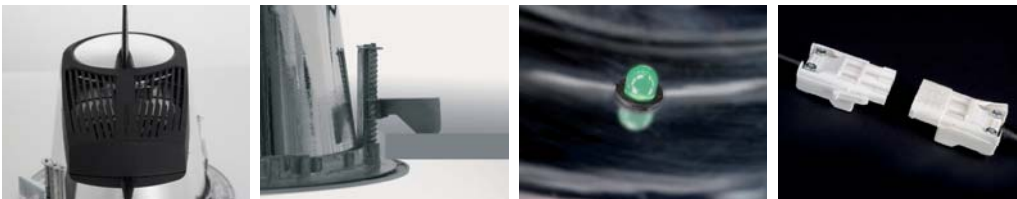

COLOUR | W □ | Z ■ |

MATERIAL |  AL+PC |  AL |

*OTHER DIM OPTIONS, PLEASE CONSULT  >> 452



ACCESSORY TRANSPARENT GLASS 230 0830-00-00 IP44



ACCESSORY PC-LOUVER 230 0831-00-00 IP20





ACCESSORY PC-LOUVER + GLASS 230* 0831-01-00 IP20

*Not available for 2 X 42W







						W
ARKITECT 180	3519-00-00-	W Z		TC-DEL	G24q-1	2 X 13W
	3520-00-00-	W Z		TC-TEL	GX24q-2	1 X 18W
	3521-00-00-	W Z		TC-TEL	GX24q-3	1 X 26W

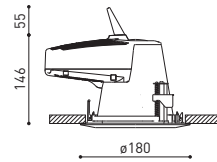
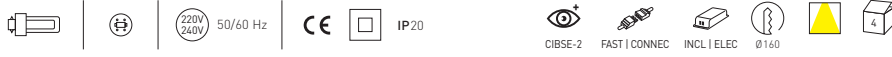

ACCESSORY TRANSPARENT GLASS 180 0832-00-00 **IP44**

COLOUR | W  | Z  |

MATERIAL |  AL+PC |  AL |

 > 452





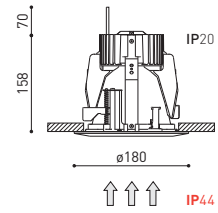

		W
ARKITECT 180 HIT-DE	3531-00-00- W Z	70W
	3532-00-00- W Z	150W



FOOD FILTER OPTIONS

	Bread	0700-04-01
	Meat	0700-04-02
	Fish	0700-04-03

COLOUR | W □ | Z ■ |

MATERIAL |  +  AL |  GL-TRANS |

 » 452

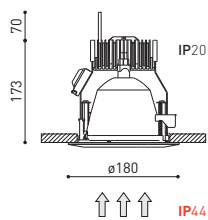

		W
ARKITECT 180 G12*	3533-00-00- W Z	35W
	3534-00-00- W Z	70W
	3535-00-00- W Z	150W



		W
ARKITECT 180 SDW-TG	3536-00-00- W Z	50W
	3537-00-00- W Z	100W



FOOD FILTER OPTIONS*

	Bread	0700-04-01
	Meat	0700-04-02
	Fish	0700-04-03

COLOUR | W □ | Z ■ |

MATERIAL | + AL | GL-TRANS |

» 452

KISS



		⊕	W
KISS	4597 R 0-00- B Z NS	G24q-2	2 X 18W
	4599 R 0-00- B Z NS	G24q-3	2 X 26W



IP43

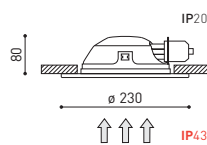

COLOUR | B □ | Z ■ | NS ■ |

MATERIAL | AL | GL-MATT |

i » 452



DRY





Photography: James Silverman - www.jamesilverman.co.uk



DRY | 4025-00-00- | B | W | 2 X 26W

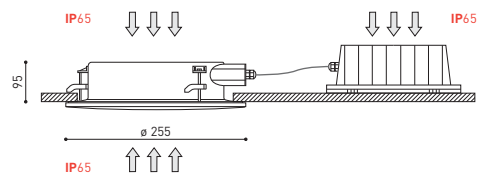

COLOUR | B □ | MATERIAL | AL | GL-MATT

» 452

TR1



		Ⓜ	W
TR1	4043-00-00- Z W	G24q-2	2 X 18W
	4041-00-00- Z W	G24q-3	2 X 26W

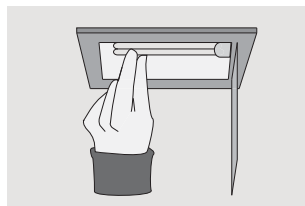
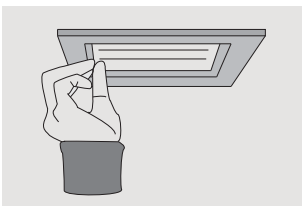
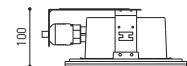
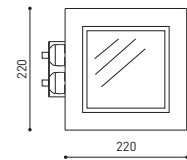
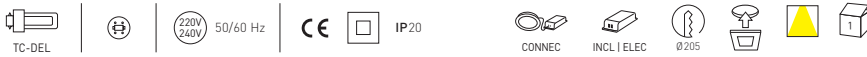

COLOUR | W □ | Z ■ |

MATERIAL | AL | GL-MATT |

» 452

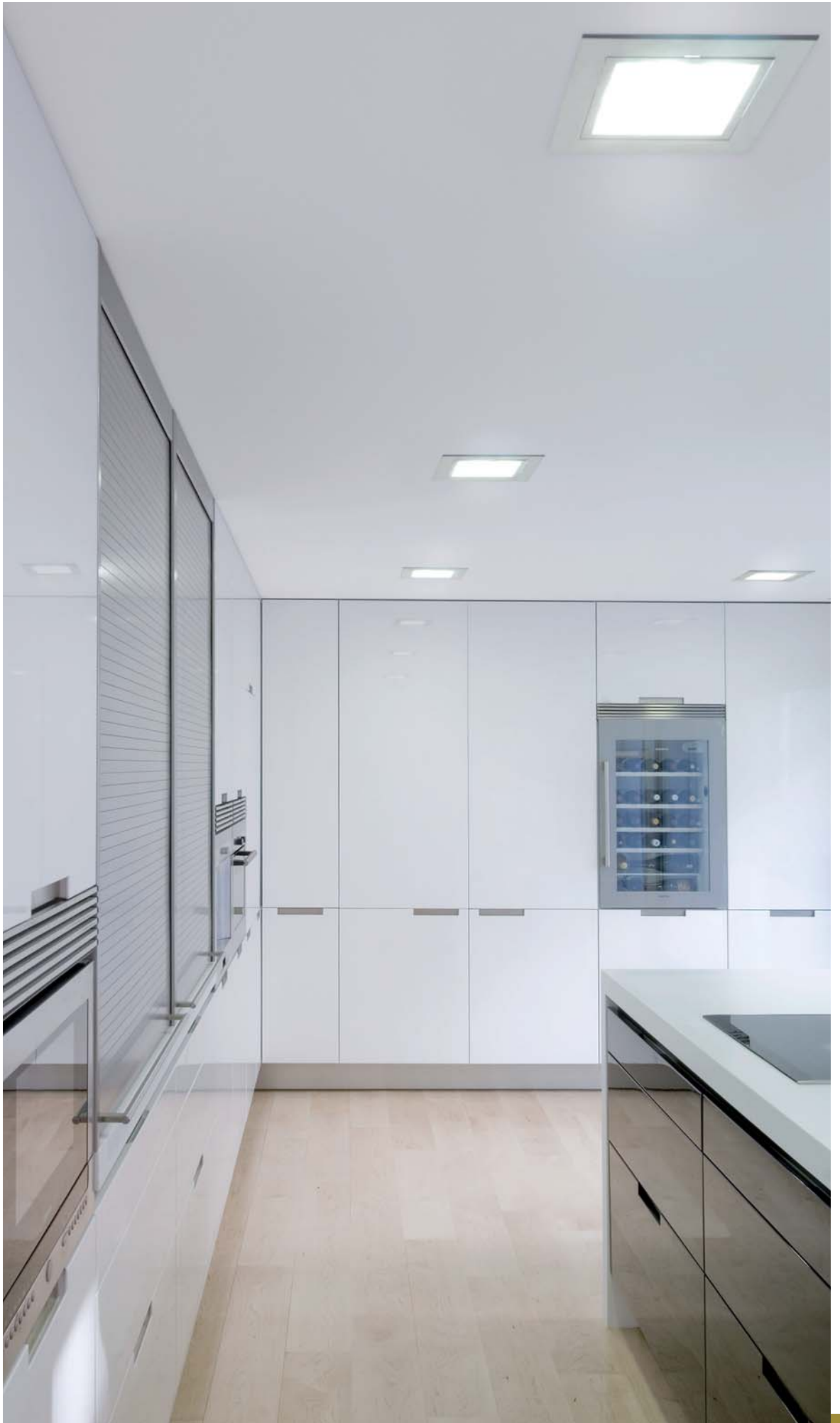

TR2

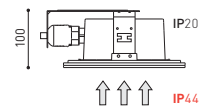
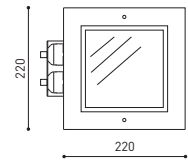

		⊕	W
TR2	4143-00-00- Z	G24q-2	2 X 18W
	4141-00-00- Z	G24q-3	2 X 26W



		W
TR2 HIT-DE	4144-00-00- Z	70W
	4145-00-00- Z	150W

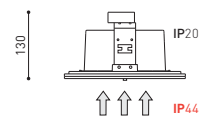
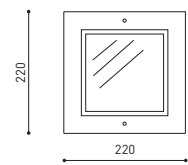

COLOUR | Z ■ | MATERIAL | AL | GL-MATT | » 452



DOT



	W	K*	Lm	L1	L2
DOT Fix 500mA A061-00-11- W NS	5W	3000K	415	52	62
DOT Fix 200mA A061-01-11- W NS	8W	3000K	625	52	62
DOT Fix 200mA A061-01-21- W NS 	8W	3000K	625	52	62
DOT Fix 300mA A061-02-11- W NS	11W	3000K	843	76	86
DOT Fix 300mA A061-02-21- W NS 	11W	3000K	843	76	86















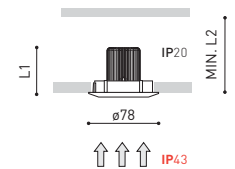

	W	K*	Lm	L1	L2
DOT Fix IP54 500mA A067-00-11- W NS	5W	3000K	415	52	62
DOT Fix IP54 200mA A067-01-11- W NS	8W	3000K	625	52	62
DOT Fix IP54 200mA A067-01-21- W NS 	8W	3000K	625	52	62
DOT Fix IP54 300mA A067-02-11- W NS	11W	3000K	843	76	86
DOT Fix IP54 300mA A067-02-21- W NS 	11W	3000K	843	76	86















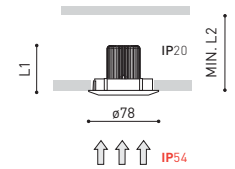

COLOUR | W | NS | MATERIAL |  AL |

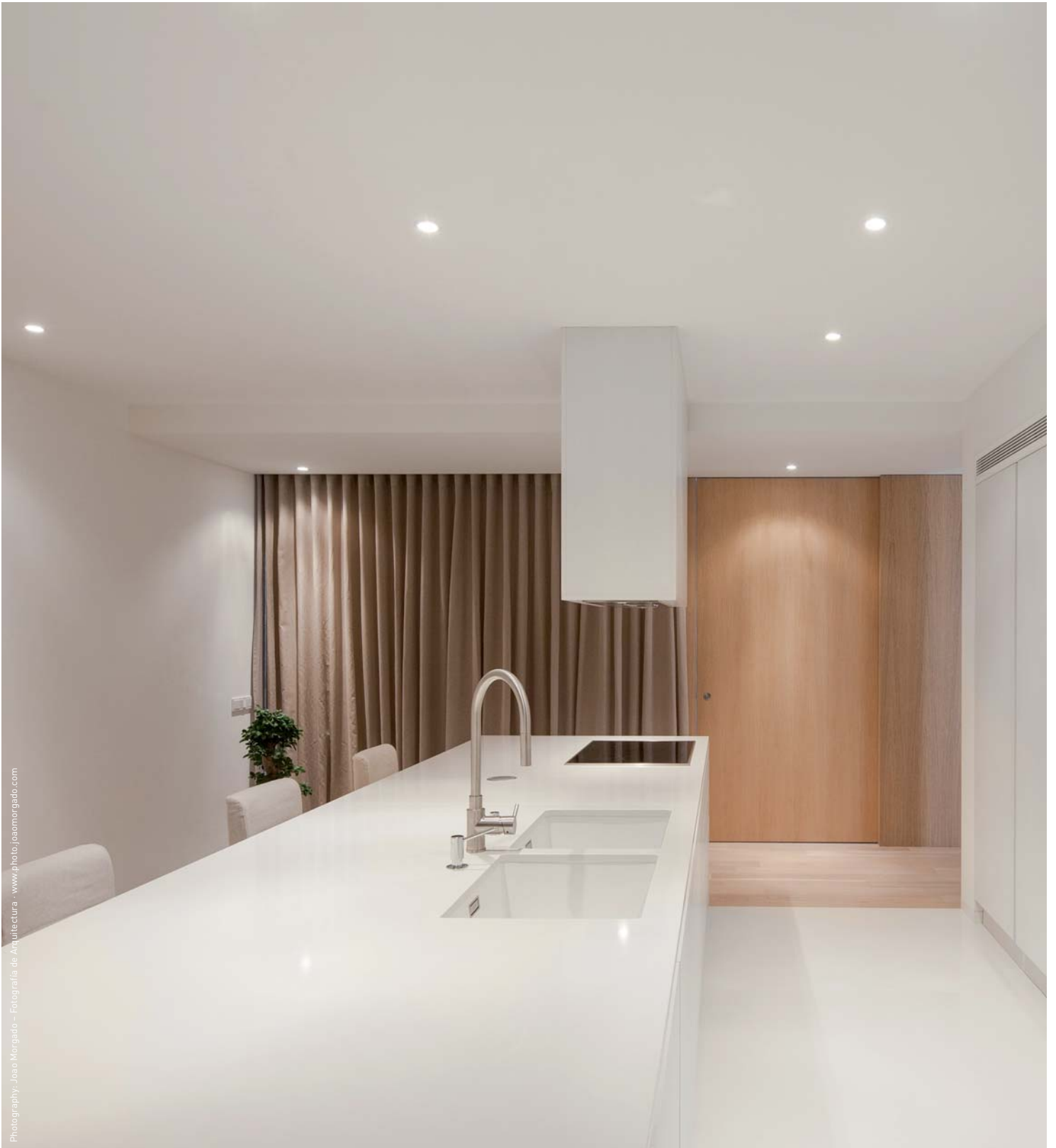

* 4000K PLEASE CONSULT  » 452  » 468



Photography: Joac Morgado - Fotografia de Arquitectura - www.photojoacmorgado.com

DOT TILT



	W	K*	Lm	L1	L2
DOT Tilt 500mA A063-00-11- W NS	5W	3000K	415	52	62
DOT Tilt 200mA A063-01-11- W NS	8W	3000K	625	52	62
DOT Tilt 200mA A063-01-21- W NS 	8W	3000K	625	52	62
DOT Tilt 300mA A063-02-11- W NS	11W	3000K	843	76	86
DOT Tilt 300mA A063-02-21- W NS 	11W	3000K	843	76	86













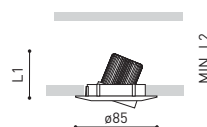

COLOUR | W □ | NS ■ |

MATERIAL |  AL |

* 4000K PLEASE CONSULT  » 452  » 468

DOT SQUARE TILT



					W	K*	Lm	L1	L2
DOT Square Tilt	500mA	A065-00-11-	W	NS	5W	3000K	415	52	62
DOT Square Tilt	200mA	A065-01-11-	W	NS	8W	3000K	625	52	62
DOT Square Tilt	200mA	A065-01-21-	W	NS	8W	3000K	625	52	62
DOT Square Tilt	300mA	A065-02-11-	W	NS	11W	3000K	843	76	86
DOT Square Tilt	300mA	A065-02-21-	W	NS	11W	3000K	843	76	86

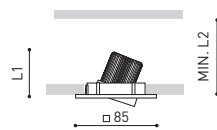

COLOUR | W □ | NS ■ |

MATERIAL | AL |

* 4000K PLEASE CONSULT ⓘ » 452 | ⓘ » 468

WIN

NEW



	W	K*	Lm	L1	L2
WIN 500mA A111-00-11- W Z NS	5W	3000K	415	66	76
WIN 200mA A111-01-11- W Z NS	8W	3000K	625	66	76
WIN 200mA A111-01-21- W Z NS	8W	3000K	625	66	76
WIN 300mA A111-02-11- W Z NS	11W	3000K	843	90	100
WIN 300mA A111-02-21- W Z NS	11W	3000K	843	90	100

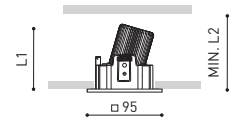

WIN 12V 0300-00-00- | W | Z | NS | MAX 50W

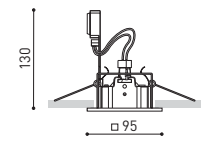

WIN 230V 0302-00-00- | W | Z | NS | MAX 50W

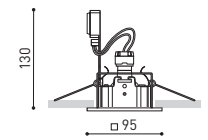

COLOUR | W | Z | NS

MATERIAL | AL

* 4000K PLEASE CONSULT » 452 » 468



WIN IP44



	W	K*	Lm	L1	L2	
WIN IP44 500mA	A113-00-11- W Z NS	5W	3000K	415	66	76
WIN IP44 200mA	A113-01-11- W Z NS	8W	3000K	625	66	76
WIN IP44 200mA	A113-01-21- W Z NS	8W	3000K	625	66	76
WIN IP44 300mA	A113-02-11- W Z NS	11W	3000K	843	90	100
WIN IP44 300mA	A113-02-21- W Z NS	11W	3000K	843	90	100

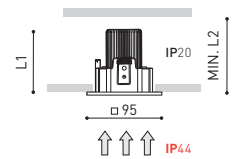
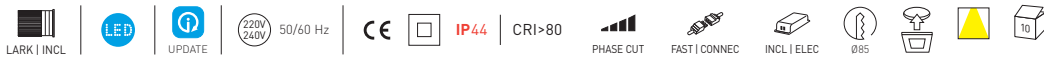

WIN IP44 12V	0301-00-00- W Z NS	W
		MAX 50W

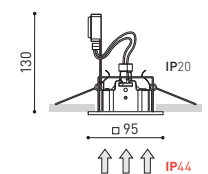
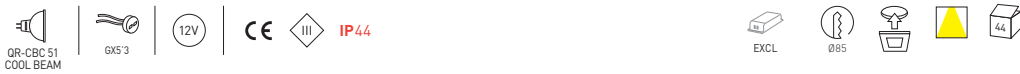

WIN IP44 230V	0331-00-00- W Z NS	W
		MAX 50W

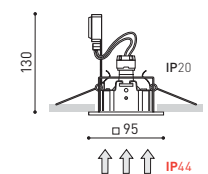

COLOUR | W □ | Z ■ | NS ■ | MATERIAL | AL | GL-MATT | * 4000K PLEASE CONSULT ⓘ » 452 | » 468

WIN IP44 OPTIC

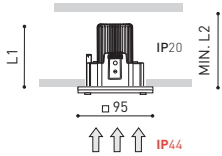

	W	K*	Lm	L1	L2	
WIN IP44 Optic 500mA	A114-00-11- Z	5W	3000K	415	66	76
WIN IP44 Optic 200mA	A114-01-11- Z	8W	3000K	625	66	76
WIN IP44 Optic 200mA	A114-01-21- Z	8W	3000K	625	66	76
WIN IP44 Optic 300mA	A114-02-11- Z	11W	3000K	843	90	100
WIN IP44 Optic 300mA	A114-02-21- Z	11W	3000K	843	90	100

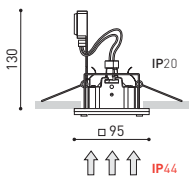

	W
WIN IP44 Optic 12V	0332-00-00- Z

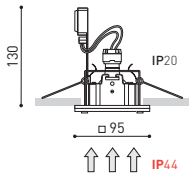

	W
WIN IP44 Optic 230V	0333-00-00- Z

COLOUR | Z ■ |

MATERIAL | AL | GL-MATT |

* 4000K PLEASE CONSULT » 452 | » 468

NEW

GAP



				W	K*	Lm	L1	L2
GAP	500mA	A171-00-11-	W	5W	3000K	415	84	94
GAP	200mA	A171-01-11-	W	8W	3000K	625	84	94
GAP	200mA	A171-01-21-	W	8W	3000K	625	84	94
GAP	300mA	A171-02-11-	W	11W	3000K	843	108	118
GAP	300mA	A171-02-21-	W	11W	3000K	843	108	118

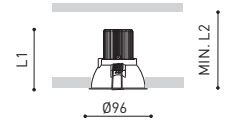

			W
GAP 12V	0354-00-00-	W	MAX 50W

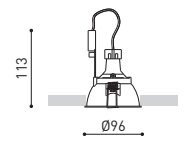

			W
GAP 230V	0355-00-00-	W	MAX 50W

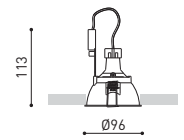

COLOUR | W □ |

MATERIAL | ZAMAK |

* 4000K PLEASE CONSULT » 452 | » 468



GAP FRAME ACCESSORY X 2 0836-02-00- | W |



GAP FRAME ACCESSORY X 4 0836-04-00- | W |

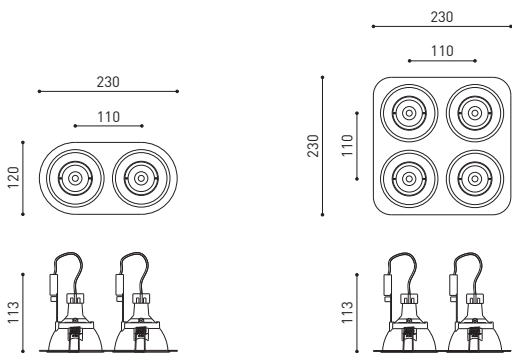

Photography: Joao Morgado - Fotografia de Arquitectura



Photography: Héctor Rubio | www.images-positive.com | Valero & Garrigues Abogados

Photography: Héctor Rubio | www.images-positive.com | Valero & Garrigues Abogados





Photography: David Fritsch - Bisimages - www.bisimages.com



GAP ASYMMETRIC



	W	K*	Lm	L1	L2	
GAP Asymmetric 500mA	A173-00-11- W	5W	3000K	415	84	94
GAP Asymmetric 200mA	A173-01-11- W	8W	3000K	625	84	94
GAP Asymmetric 200mA	A173-01-21- W	8W	3000K	625	84	94
GAP Asymmetric 300mA	A173-02-11- W	11W	3000K	843	108	118
GAP Asymmetric 300mA	A173-02-21- W	11W	3000K	843	108	118

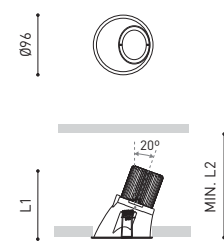

	W
GAP Asymmetric 12V	A181-01-01- W MAX 50W

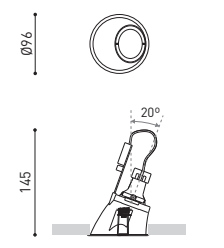

	W
GAP Asymmetric 230V	A182-01-01- W MAX 50W

COLOUR | W □ | MATERIAL | ZAMAK | * 4000K PLEASE CONSULT » 452 | » 468



Photography: James Silverman - www.jamesilverman.co.uk

NEW

MEC



	W	K*	Lm	L1	L2
MEC Tilt 500mA A151-00-11- P	5W	3000K	415	52	62
MEC Tilt 200mA A151-01-11- P	8W	3000K	625	52	62
MEC Tilt 200mA A151-01-21- P	8W	3000K	625	52	62
MEC Tilt 300mA A151-02-11- P	11W	3000K	843	76	86
MEC Tilt 300mA A151-02-21- P	11W	3000K	843	76	86

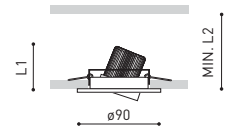

	W
MEC Tilt 12V 0029-00-00- P	MAX 50W

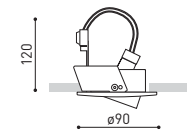

	W
MEC Tilt 230V 0030-00-00- P	MAX 50W

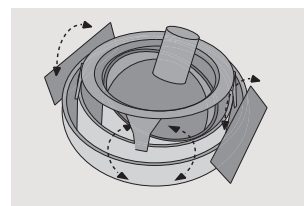
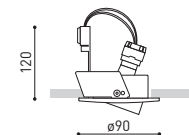

COLOUR | P ■ | MATERIAL | AL

MEC SQUARE TILT

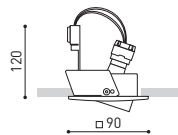
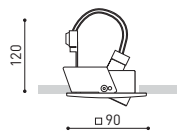
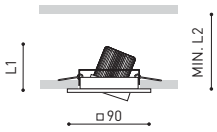

	W	K*	Lm	L1	L2
MEC Square Tilt 500mA A153-00-11- P	5W	3000K	415	52	62
MEC Square Tilt 200mA A153-01-11- P	8W	3000K	625	52	62
MEC Square Tilt 200mA A153-01-21- P	8W	3000K	625	52	62
MEC Square Tilt 300mA A153-02-11- P	11W	3000K	843	76	86
MEC Square Tilt 300mA A153-02-21- P	11W	3000K	843	76	86



	W
MEC Square Tilt 12V 0313-00-00- P	MAX 50W

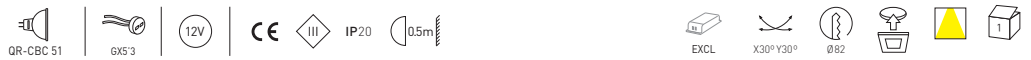

	W
MEC Square Tilt 230V 0314-00-00- P	MAX 50W



* 4000K PLEASE CONSULT ⓘ » 452 | ⓘ » 468





MEC 1-3W



K

MEC 1-3W Tilt	0031-00-33- P	3000 K
	0031-00-43- P	4000 K

1-3W | 350-700 mA | IP20 | CRI>80 | EXCL | 30° | Ø43 | 30° |

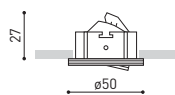

COLOUR | P ■ | MATERIAL | AL |

» 452

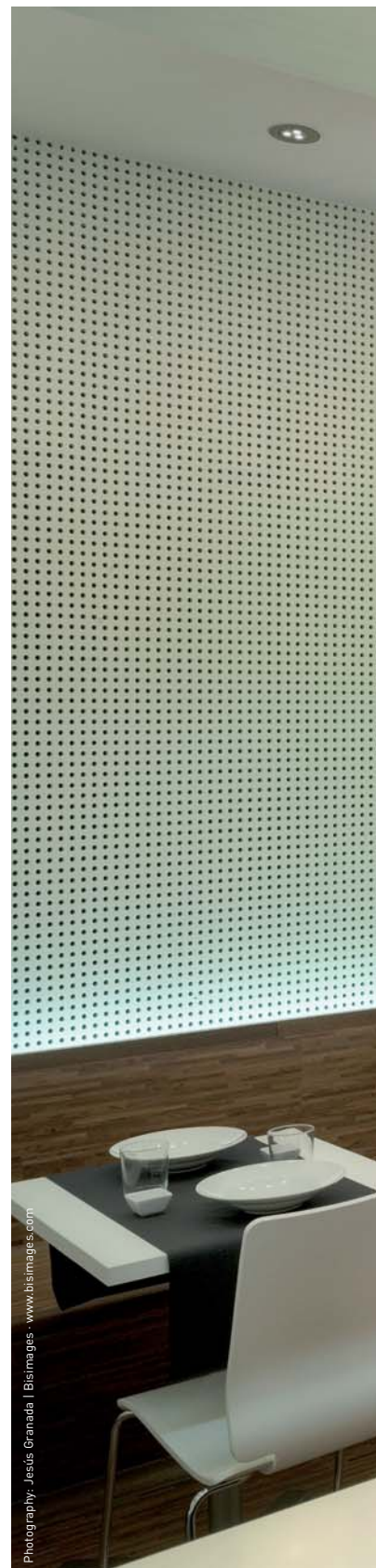

Photography: Jesús Granada | Bisimages - www.bisimages.com

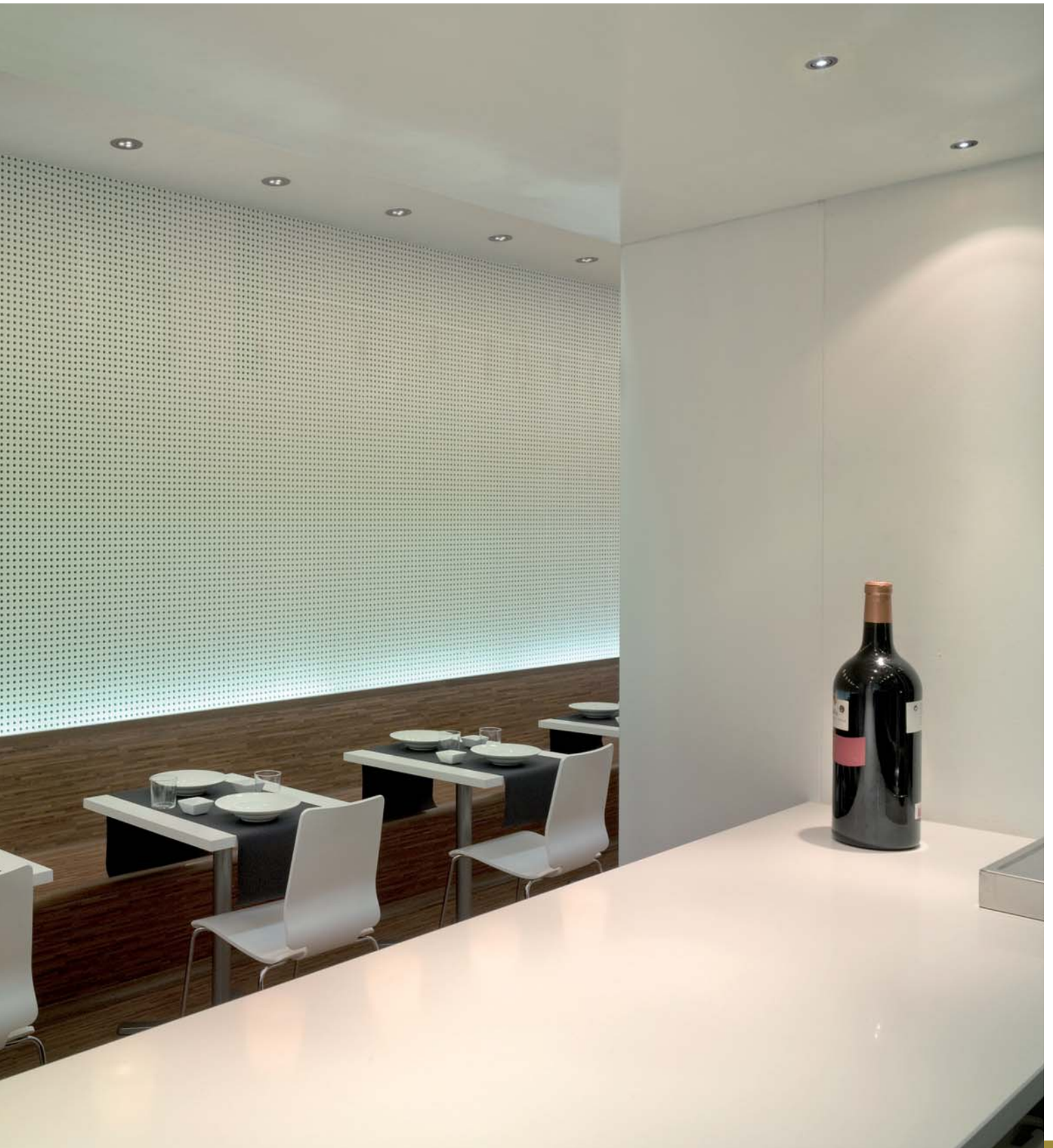

NEW

EYE



				W	K*	Lm	L1	L2
EYE Tilt	500mA	A131-00-11-	W	5W	3000K	415	48	58
EYE Tilt	200mA	A131-01-11-	W	8W	3000K	625	48	58
EYE Tilt	200mA	A131-01-21-	W	8W	3000K	625	48	58
EYE Tilt	300mA	A131-02-11-	W	11W	3000K	843	72	82
EYE Tilt	300mA	A131-02-21-	W	11W	3000K	843	72	82

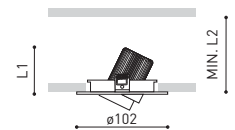

COLOUR | W □ | MATERIAL | AL |

* 4000K PLEASE CONSULT » 452 | » 468

EYE SQUARE TILT

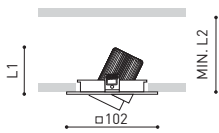

	W	K*	Lm	L1	L2
EYE Square Tilt 500mA A133-00-11- W	5W	3000K	415	48	58
EYE Square Tilt 200mA A133-01-11- W	8W	3000K	625	48	58
EYE Square Tilt 200mA A133-01-21- W	8W	3000K	625	48	58
EYE Square Tilt 300mA A133-02-11- W	11W	3000K	843	72	82
EYE Square Tilt 300mA A133-02-21- W	11W	3000K	843	72	82

LARK | INCL |
 LED |
 UPDATE |
 220V/240V |
 50/60 Hz |
 CE |
 IP20 |
 CRI>80 |
 PHASE CUT |
 FAST | CONNEC |
 INCL | ELEC |
 355° |
 25° |
 Ø92 |
 |
 40° |
 10



COLOUR | W □ | MATERIAL | AL |

* 4000K PLEASE CONSULT » 452 | » 468



Photography: Diego Opazo - www.diegoopazo.com



NEW

BATH



	W	K*	Lm	L1	L2
BATH 500mA A155-00-11- W C Q	5W	3000K	415	60	70
BATH 200mA A155-01-11- W C Q	8W	3000K	625	60	70
BATH 200mA A155-01-21- W C Q	8W	3000K	625	60	70
BATH 300mA A155-02-11- W C Q	11W	3000K	843	84	94
BATH 300mA A155-02-21- W C Q	11W	3000K	843	84	94

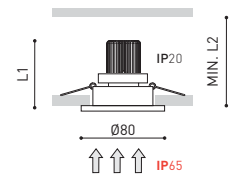

	W
BATH 12V 0350-00-00- W C Q	MAX 50W

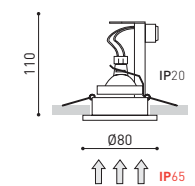

COLOUR | W □ | C ■ | Q ■ |

MATERIAL | AL |

* 4000K PLEASE CONSULT » 452 » 468





BATH SQUARE

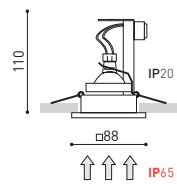
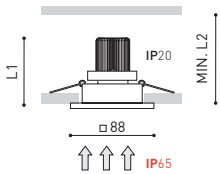

	W	K*	Lm	L1	L2
BATH Square 500mA A157-00-11- W C Q	5W	3000K	415	60	70
BATH Square 200mA A157-01-11- W C Q	8W	3000K	625	60	70
BATH Square 200mA A157-01-21- W C Q	8W	3000K	625	60	70
BATH Square 300mA A157-02-11- W C Q	11W	3000K	843	84	94
BATH Square 300mA A157-02-21- W C Q	11W	3000K	843	84	94



	W
BATH SQUARE 12V 0351-00-00- W C Q	MAX 50W



COLOUR | W □ | C ■ | Q ■ |

MATERIAL | AL |

* 4000K PLEASE CONSULT ⓘ » 452 | ⓘ » 468

NEW

GIRO



			W	K	Lm	%Eff
GIRO	200mA	A210-00-11- W	8W	3000K	695	90%
		A210-00-21- W	8W	3000K	695	90%

50/60 Hz

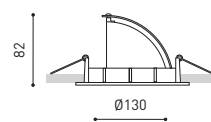

COLOUR | W □ | MATERIAL | AL |

» 452 | » 468



DECO



W

DECO 0120-00-00- | B | C | **MAX 20W**

QT-9 G4 12V CE III IP20 EXCL Ø55 150

15 |

 ø64

W

DECO Surface 0202-00-00- | B | C | **MAX 20W**

QT-9 G4 12V CE III IP20 EXCL 150

21 |

 ø64



W

DECO Fix 12V 0014-00-00- | B | NS | Q | **MAX 50W**

QR-CBC 51 LED GXS'3 12V EXCL Ø60 1

CE III IP20 0.5m

92 |

 ø82

W

DECO Tilt 12V 0017-00-00- | B | NS | Q | **MAX 50W**

QR-CBC 51 LED GXS'3 12V EXCL Ø85 20° 1

CE III IP20 0.5m

97 |

 ø110

COLOUR | B □ | C ■ | NS ■ | Q ■ |

MATERIAL | AL | *LED OPTIONS & » 452



SECRET



SECRET Tilt 0345-00-00- | Z | W | W
MAX 1 X 50W

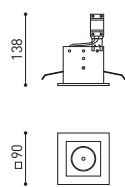

COLOUR | Z ■ | W □ | ⓘ » 452



Photography: Joao Morgado - Fotografia de Arquitectura - www.photo.jaomorgado.com





W

SECRET Wall Washer 0346-00-00- | Z | W | MAX 1 X 50W

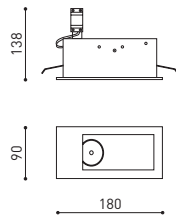

COLOUR | Z ■ | W □ | ⓘ » 452





Photography: James Silverman - www.jamesilverman.co.uk







W

SECRET Double

0347-00-00- | Z | W |

MAX 2 X 50W



QR-CBC 51



GX53



12V



CE



III



IP20



0.5m



EXCL



45°



72 X 173



Warning



Box

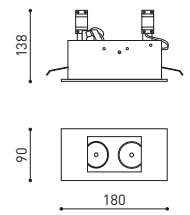

COLOUR | Z ■ | W □ |

i » 452

CIBER



W

CIBER 12V 0341-00-00- | W | N | Z | NS | **MAX 50W**















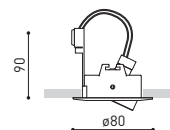

W

CIBER 230V 0343-00-00- | W | N | Z | NS | **MAX 50W**











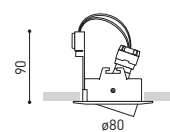

COLOUR | W □ | N ■ | Z ■ | NS ■ |

MATERIAL | AL | ⓘ >> 452

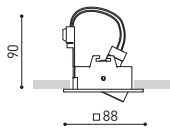

CIBER Square 12V

0342-00-00- | W | N | Z | NS |

W

MAX 50W

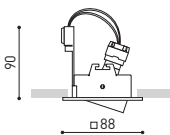
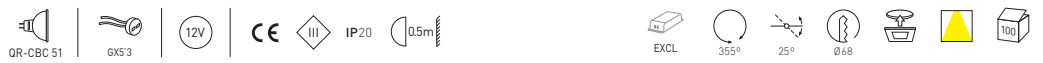

CIBER Square 230V

0344-00-00- | W | N | Z | NS |

W

MAX 50W



COLOUR | W | N | Z | NS |

MATERIAL | AL | » 452





BASIC



W

BASIC Fix 12V 0037-01-01- | B | N | Z | C | NS | Q | **MAX 50W**

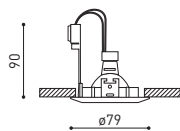

W

BASIC Tilt 12V 0038-01-01- | B | N | Z | C | NS | Q | **MAX 50W**

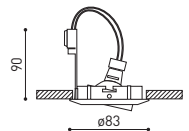

W

BASIC Fix 230V 0337-01-01- | B | N | Z | C | NS | Q | **MAX 50W**

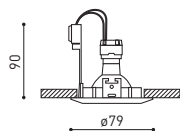

W

BASIC Tilt 230V 0338-01-01- | B | N | Z | C | NS | Q | **MAX 50W**

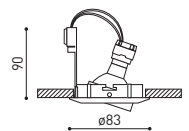

COLOUR | B □ | N ■ | Z ■ | C ■ | NS ■ | Q ■ |



W

BASIC Square Fix 12V | 0303-00-00- | B | Z | NS | **MAX 50W**

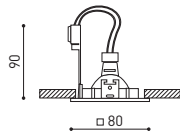

W

BASIC Square Fix 230V | 0307-00-00- | B | Z | NS | **MAX 50W**

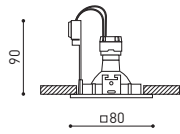

W

BASIC Square Tilt 12V | 0304-00-00- | B | Z | NS | **MAX 50W**

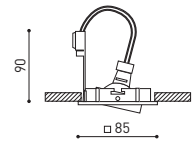

W

BASIC Square Tilt 230V | 0308-00-00- | B | Z | NS | **MAX 50W**

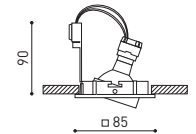

MATERIAL | AL | *LED OPTIONS & » 452







W

BASIC Tilt Extra 12V 0321-01-01- | B | C | NS | Q | **MAX 50W**

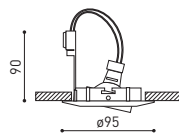

W

BASIC Tilt Extra 230V 0325-01-01- | B | C | NS | Q | **MAX 50W**

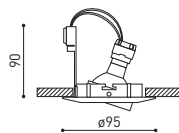

COLOUR | B | C | NS | Q |

Restaurante Lienzo





NEW

FUNGHI



			W
FUNGHI	A186-01-01- WT		55W
	A186-02-01- WT		55W





 50/60 Hz |
 

 IP20





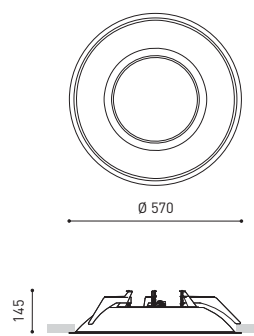



COLOUR | WT □ | MATERIAL |  AL |

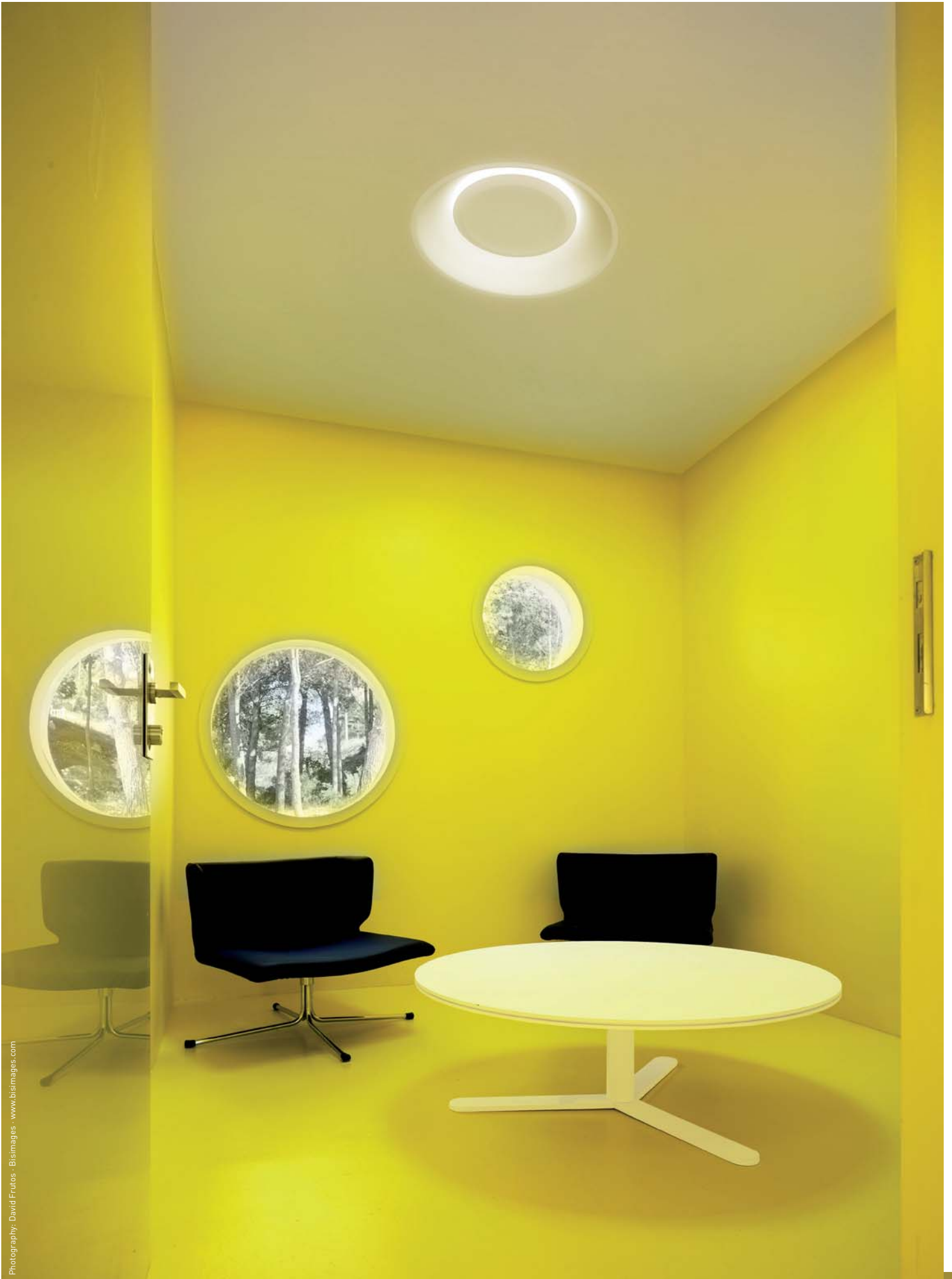









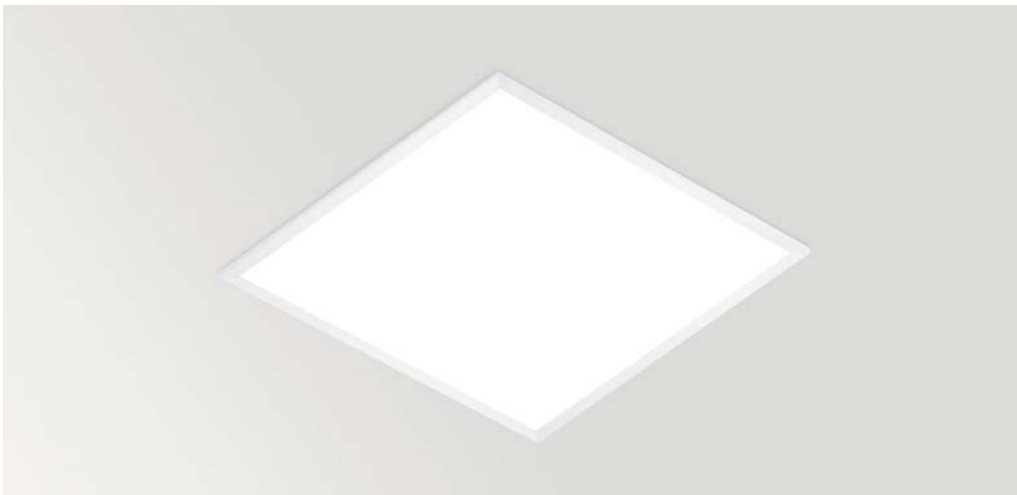

NEW

OFFICE



		W	K	Lm	%Eff
OFFICE	A211-00-11- W	35W	4000K	4600	74%
	A211-00-21- W 	35W	4000K	4600	74%











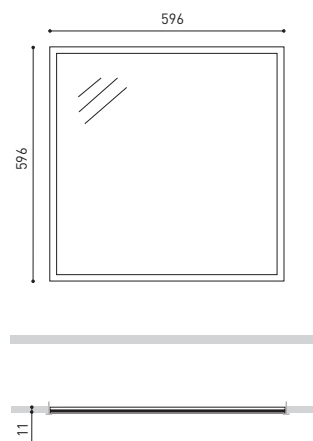

COLOUR | W □ |

MATERIAL |  AL |  PC |

 » 452 |  » 468



Photography: Joso Morgado - Fotografía de Arquitectura - www.photo.josomorgado.com





Photography: Jaso Morgado - Fotografía de Arquitectura - www.photo.jasomorgado.com

ARKOS T5

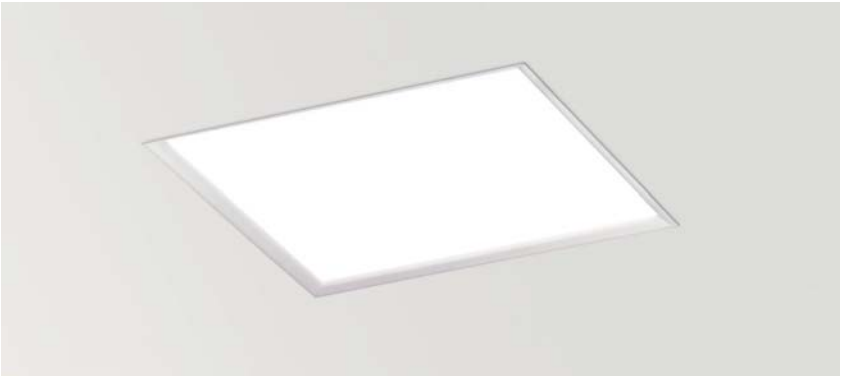

				W
ARKOS T5 C	2303-04-24-	Z W 	575 X 575	4 X 24W

| | 50/60 Hz | | | |

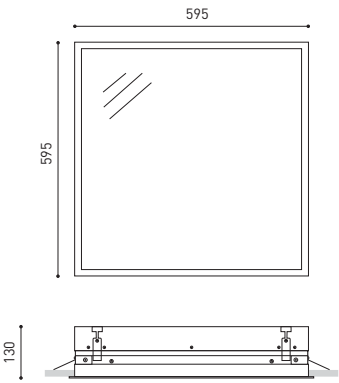

COLOUR | Z ■ | W □ | MATERIAL | AL | PC | > 452

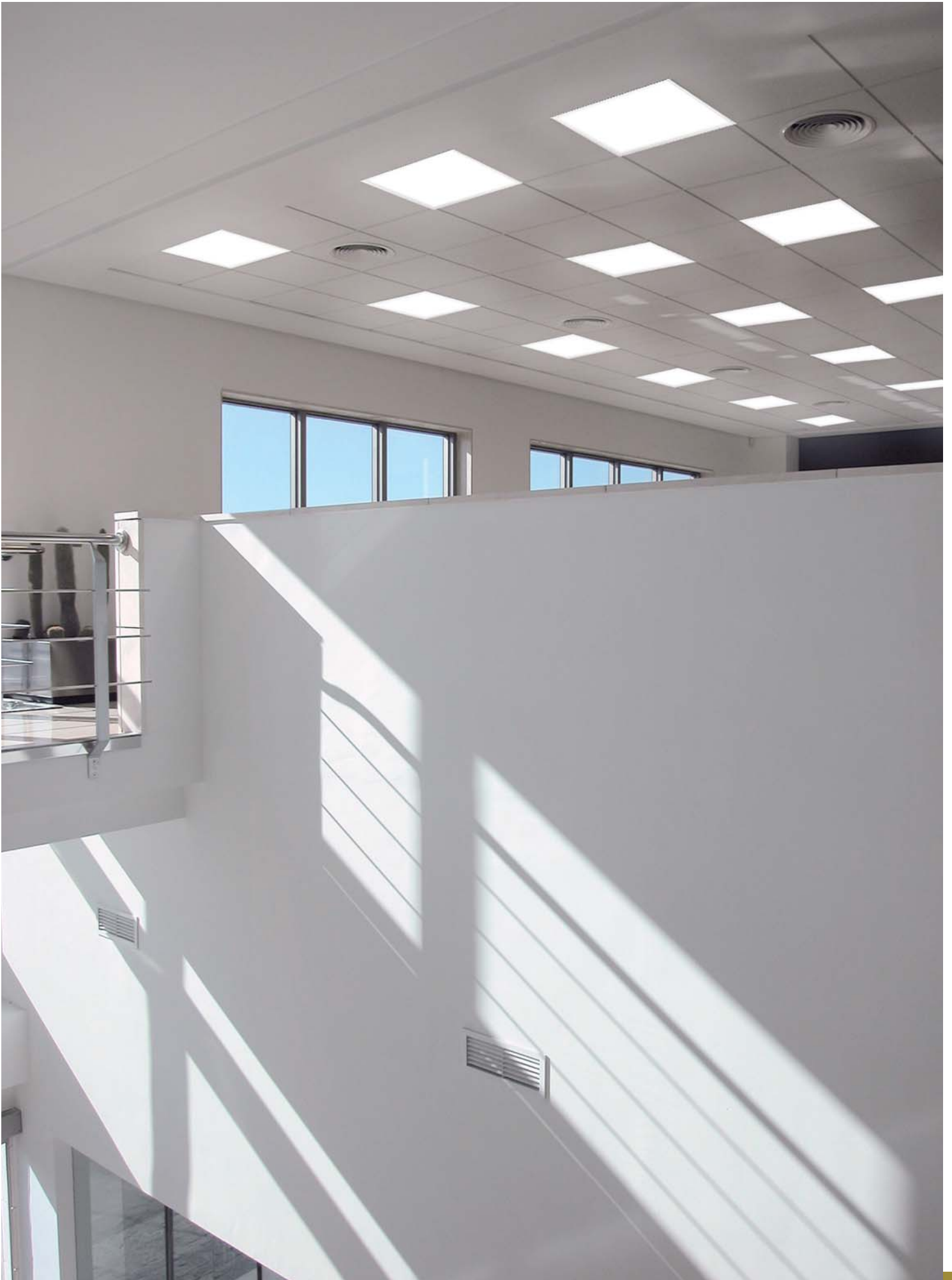

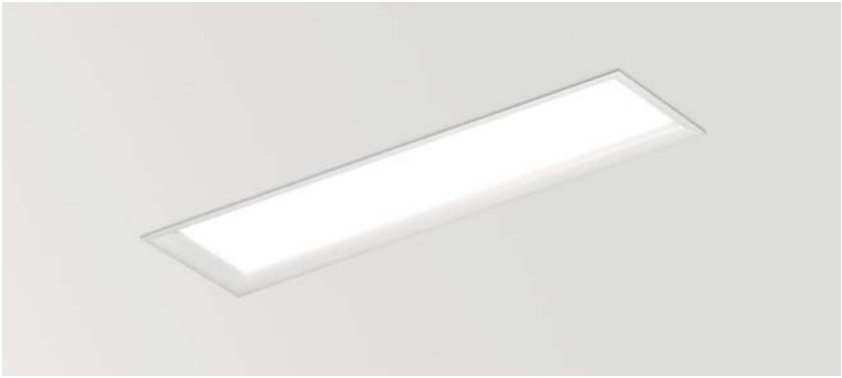

ARKOS T5 L	2303-02-24-	Z	W	156 X 602	2 X 24W
	2303-02-54-	Z	W	156 X 1202	2 X 54W

 T5 |
  G5 |
  220V/240V 50/60 Hz |
  CE |
  |
 IP20 |
  INCL | ELEC |
  |
  1

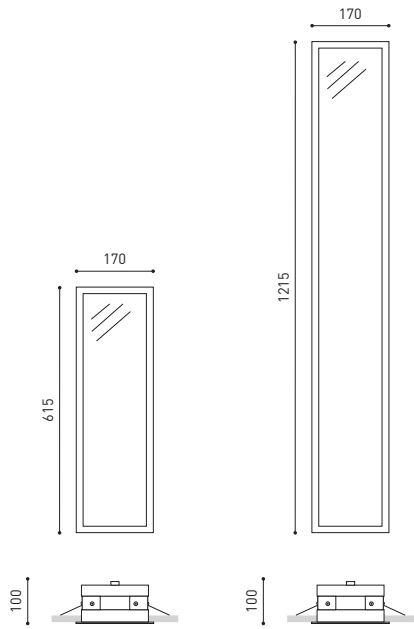

COLOUR | Z ■ | W □ |
 MATERIAL |  AL |  PC |
 ⓘ > 452







NEW

TWIST



				W	BEAM	K	mA	Lm	%Eff
TWIST 1	A204-11-11-	WT		10,5W	24°	3000K	500	1070	94%
	A204-11-21-	WT		10,5W	50°	3000K	500	1070	92%
	A204-11-12-	WT		10,5W	24°	4000K	500	1200	94%
	A204-11-22-	WT		10,5W	50°	4000K	500	1200	92%
TWIST 1 DIM	A204-12-11-	WT	▬▬▬▬	10,5W	24°	3000K	500	1070	94%
	A204-12-21-	WT	▬▬▬▬	10,5W	50°	3000K	500	1070	92%
	A204-12-12-	WT	▬▬▬▬	10,5W	24°	4000K	500	1200	94%
	A204-12-22-	WT	▬▬▬▬	10,5W	50°	4000K	500	1200	92%

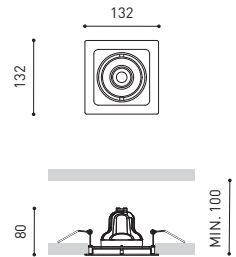

50/60 Hz



COLOUR | WT | MATERIAL | AL

» 452 | » 468







- 1** Salas de Espera
Consultas 2 a 9
Reproducción
Ginecología
Oftalmología
Habitaciones 1 a 9
Área Quirúrgica
Quirófano
Laboratorio Enxovado
Informática
Biblioteca
- 0** Zona A
Recepción
Atención al Paciente
Consulta 1
Extracción de Sangre
Oxigenación de Muestras
Laboratorio General / Anatomía
Administración
Dirección
- Zona B
Salón de Actos
Staff

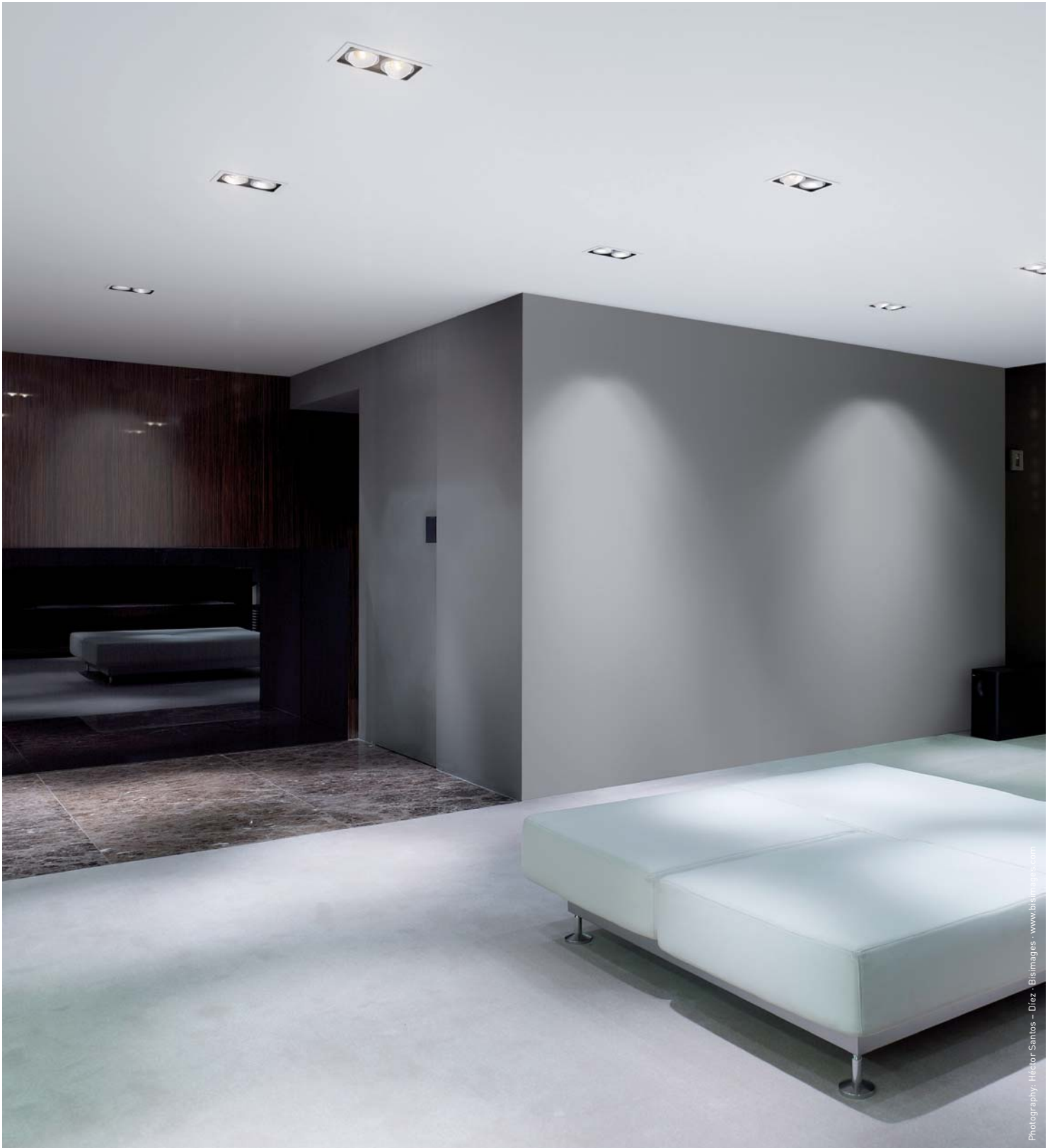

Photography: Héctor Santos - Díez - Bismages - www.bismages.com

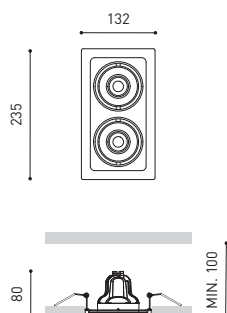

			W	BEAM	K	mA	Lm	%Eff
TWIST 2	A204-21-11- WT		2 X 10,5W	24°	3000K	500	2 X 1070	94%
	A204-21-21- WT		2 X 10,5W	50°	3000K	500	2 X 1070	92%
	A204-21-12- WT		2 X 10,5W	24°	4000K	500	2 X 1200	94%
	A204-21-22- WT		2 X 10,5W	50°	4000K	500	2 X 1200	92%
TWIST 2 DIM	A204-22-11- WT	▬▬▬	2 X 10,5W	24°	3000K	500	2 X 1070	94%
	A204-22-21- WT	▬▬▬	2 X 10,5W	50°	3000K	500	2 X 1070	92%
	A204-22-12- WT	▬▬▬	2 X 10,5W	24°	4000K	500	2 X 1200	94%
	A204-22-22- WT	▬▬▬	2 X 10,5W	50°	4000K	500	2 X 1200	92%



COLOUR | WT

MATERIAL | AL

[i](#) » 452 | [G](#) » 468





BY MOMODESIGN

ARKOSLIGHT

NEW

LOOK BY MOMODESIGN

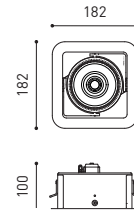

W

LOOK 1 Lark-111 A020-11-01- | W | N | MAX 1 X 15W

LARK-111 | EXCL**
 LED
 UPDATE
 220V/240V
 50/60 Hz
 CE
 IP20
 EXCL
 X35°Y30°
 162 X 162

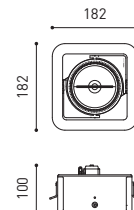

W

LOOK 1 QR-111 A020-01-01- | W | N | MAX 1 X 75W

QR-111
 LED
 LARK-111 | 12 V
 G53
 12V
 CE
 III
 IP20
 0.5m
 EXCL
 X35°Y30°
 162 X 162

W

LOOK 1 CDM-R111 A020-01-02- | W | N | MAX 1 X 70W

CDM-R111
 GX8.5
 CE
 IP20
 1m
 EXCL
 X35°Y35°
 162 X 162

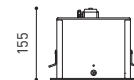

COLOUR | W | N |

MATERIAL | AL | > 452

* LARK 111 | 12V & ** LARK 111 OPTIONS > 453 | > 468

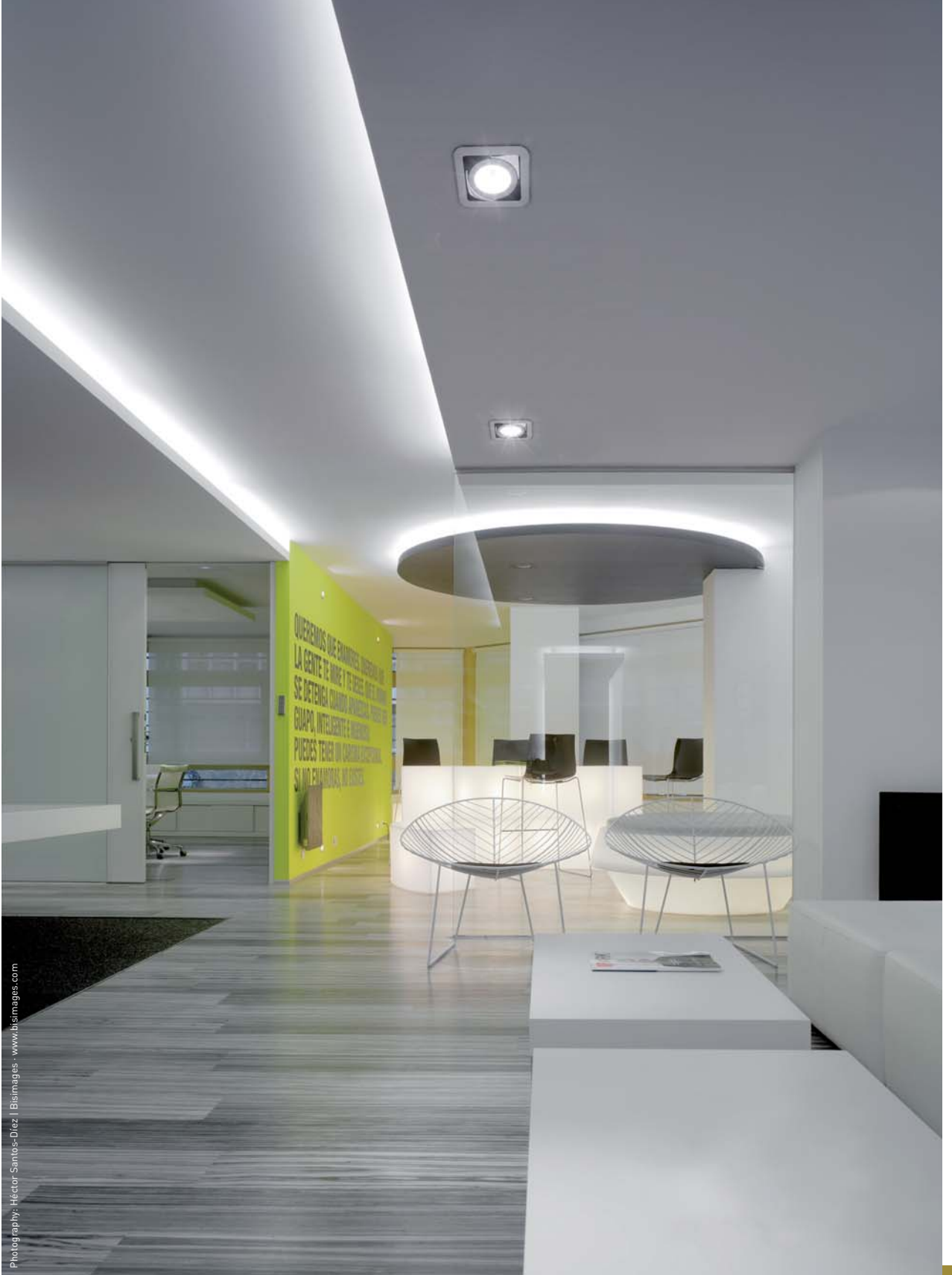

Photography: Héctor Santóys-Díaz | Bismages - www.bismages.com

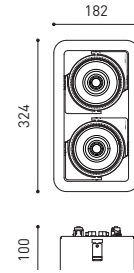

W

LOOK 2 Lark-111 A020-12-01- | W | N | MAX 2 X 15W

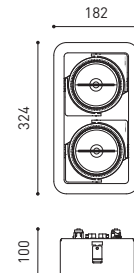

W

LOOK 2 QR-111 A020-02-01- | W | N | MAX 2 X 75W



W

LOOK 2 CDM-R111 A020-02-02- | W | N | MAX 2 X 70W

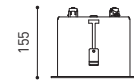

COLOUR | W □ | N ■ |

MATERIAL | AL | ⓘ > 452

* LARK 111 | 12V  & ** LARK 111 OPTIONS > 453 | ⓘ > 468



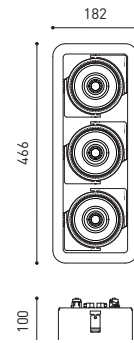

W

LOOK 3 Lark-111 A020-13-03- | W | N | MAX 3 X 15W

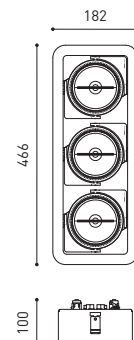

W

LOOK 3 QR-111 A020-03-03- | W | N | MAX 3 X 75W



W

LOOK 3 Combi A020-03-01- | W | N | MAX 2 X 75W | MAX 1 X 70W

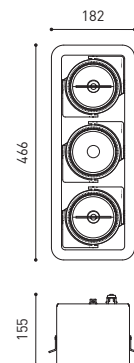

COLOUR | W □ | N ■ |

MATERIAL | AL | ⓘ > 452

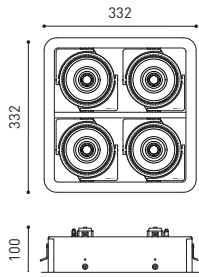

W

LOOK 4 Lark-111

A020-14-01- | W | N |

MAX 4 X 15W

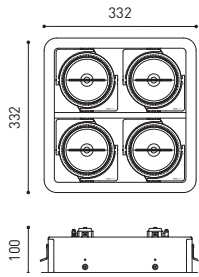

W

LOOK 4 QR-111

A020-04-01- | W | N |

MAX 4 X 75W



* LARK 111 | 12V  & ** LARK 111 OPTIONS » 453 |  » 468

NEW

LOOK TRIMLESS BY MOMODESIGN

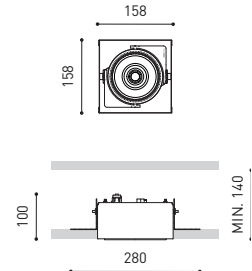

W

LOOK TRIMLESS 1 **Lark-111** A020-11-03- | W | N | **MAX 1 X 15W**

LARK-111 | EXCL** |
 LED |
 UPDATE |
 220V/240V | 50/60 Hz |
 CE |
 IP20 |
 EXCL |
 X35° Y30° |
 166 X 166 |

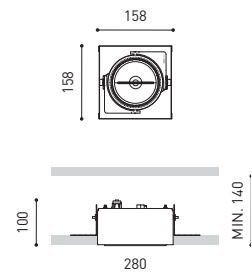

W

LOOK TRIMLESS 1 **QR-111** A020-01-03- | W | N | **MAX 1 X 75W**

QR-111 |
 LED | LARK-111 | 12 V |
 OPTIONS* |
 G53 |
 12V |
 CE |
 III |
 IP20 |
 0.5m |
 EXCL |
 X35° Y30° |
 166 X 166 |

W

LOOK TRIMLESS 1 **CDM-R111** A020-01-04- | W | N | **MAX 1 X 70W**

CDM-R111 |
 GX85 |
 CE |
 IP20 |
 1m |
 EXCL |
 X35° Y35° |
 166 X 166 |

COLOUR | W | N |

MATERIAL | AL | >> 452

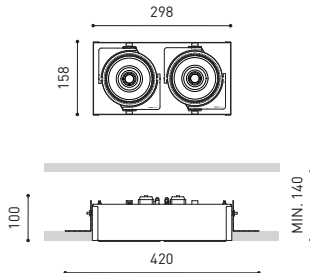

W

LOOK TRIMLESS 2 Lark-111

A020-12-03- | W | N |

MAX 2 X 15W

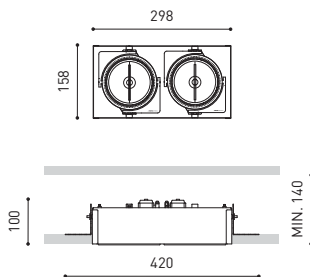

W

LOOK TRIMLESS 2 QR-111

A020-02-03- | W | N |

MAX 2 X 75W

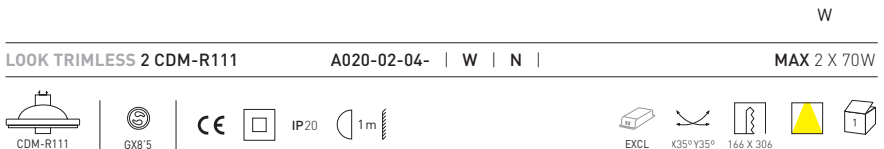
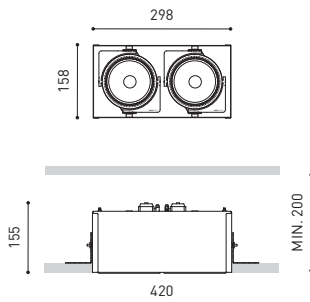

W

LOOK TRIMLESS 2 CDM-R111

A020-02-04- | W | N |

MAX 2 X 70W



* LARK 111 | 12V  & ** LARK 111 OPTIONS » 453 |  » 468





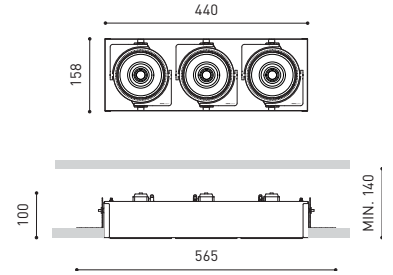

W

LOOK TRIMLESS 3 Lark-111 A020-13-04- | W | N | MAX 3 X 15W

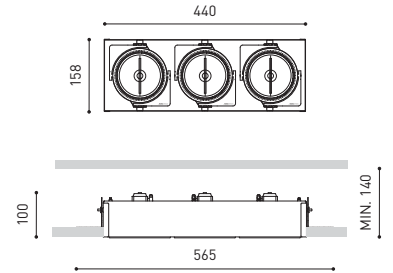

W

LOOK TRIMLESS 3 QR-111 A020-03-04- | W | N | MAX 3 X 75W



W

LOOK TRIMLESS 3 Combi A020-03-02- | W | N | MAX 2 X 75W | MAX 1 X 70W

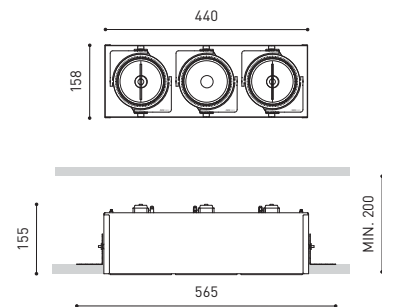

COLOUR | W □ | N ■ |

MATERIAL | AL | > 452

* LARK 111 | 12V & ** LARK 111 OPTIONS > 453 | > 468

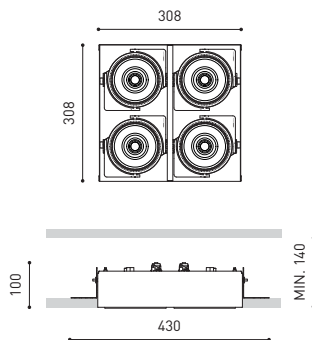

W

LOOK TRIMLESS 4 Lark-111

A020-14-02- | W | N |

MAX 4 X 15W

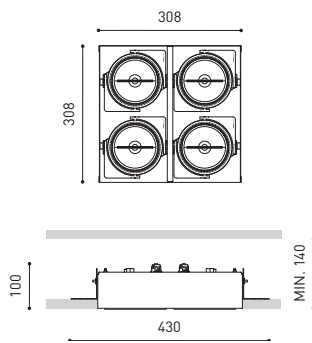

W

LOOK TRIMLESS 4 QR-111

A020-04-02- | W | N |

MAX 4 X 75W



NEW EASY SYSTEM

All LOOK Trimless - Box included

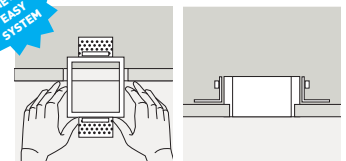

TRIMLESS MOUNTING » 464

NEW

ORBITAL

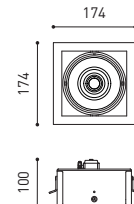

W

ORBITAL 1 Lark-111 A010-11-01- | Z | W | N | MAX 1 X 15W

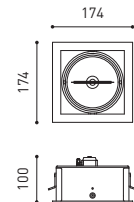

W

ORBITAL 1 QR-111 A010-01-01- | Z | W | N | MAX 1 X 75W



W

ORBITAL 1 CDM-R111 A010-01-02- | Z | W | N | MAX 1 X 70W

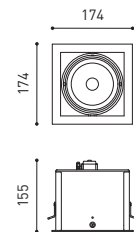

COLOUR | Z ■ | W □ | N ■ |

MATERIAL | AL | ⓘ >> 452

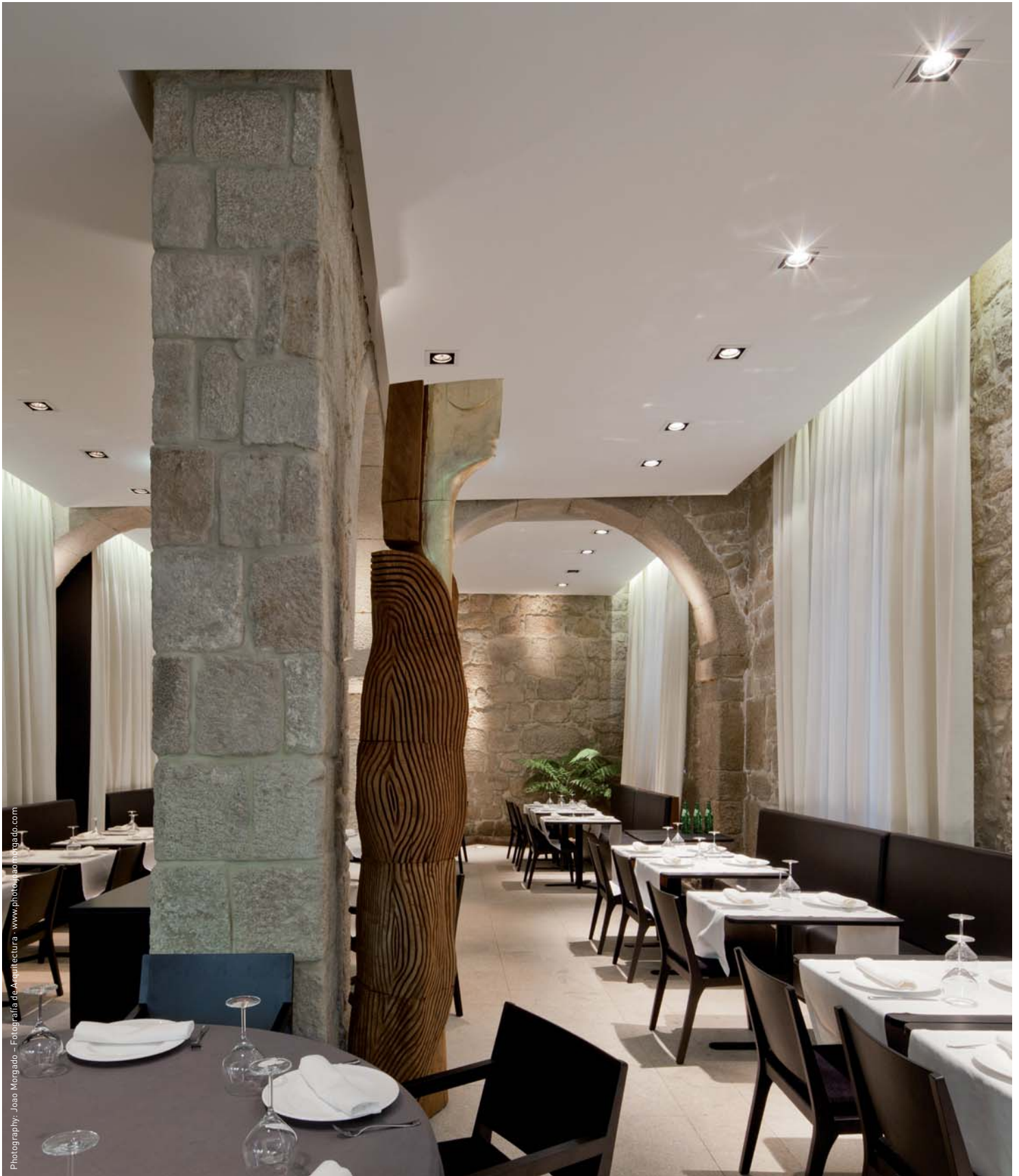

Photography: Joao Morgado - Fotografia de Arquitectura - www.fotografiamorgado.com

* LARK 111 | 12V  & ** LARK 111 OPTIONS » 453 |  » 468





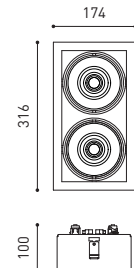

W

ORBITAL 2 Lark-111 A010-12-01- | Z | W | N | MAX 2 X 15W

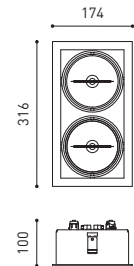

W

ORBITAL 2 QR-111 A010-02-01- | Z | W | N | MAX 2 X 75W



W

ORBITAL 2 CDM-R111 A010-02-02- | Z | W | N | MAX 2 X 70W

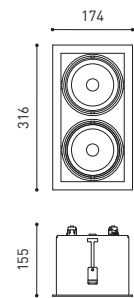

COLOUR | Z ■ | W □ | N ■ |

MATERIAL | AL | ⓘ > 452

* LARK 111 | 12V  & ** LARK 111 OPTIONS > 453 | ⓘ > 468







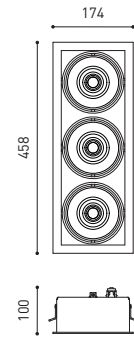

W

ORBITAL 3 Lark-111 A010-13-05- | Z | W | N | **MAX 3 X 15W**

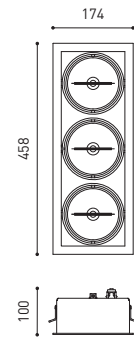

W

ORBITAL 3 QR-111 A010-03-05- | Z | W | N | **MAX 3 X 75W**



W

ORBITAL 3 Combi A010-03-01- | Z | W | N | **MAX 2 X 75W | MAX 1 X 70W**

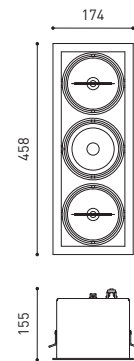
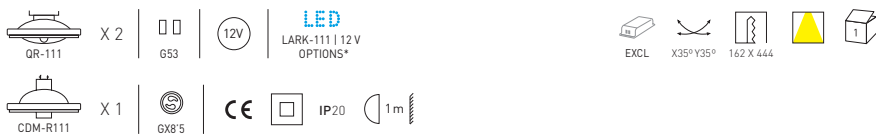

COLOUR | Z ■ | W □ | N ■ | MATERIAL | AL | i >> 452

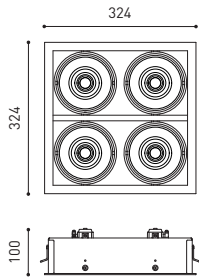

W

ORBITAL 4 Lark-111

A010-14-01- | Z | W | N |

MAX 4 X 15W

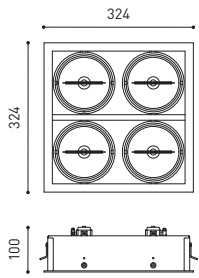

W

ORBITAL 4 QR-111

A010-04-01- | Z | W | N |

MAX 4 X 75W



* LARK 111 | 12V  & ** LARK 111 OPTIONS » 453 |  » 468

NEW

ORBITAL TRIMLESS

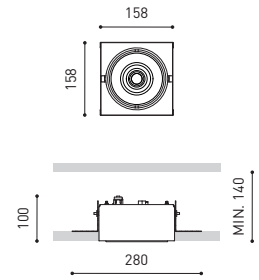

W

ORBITAL TRIMLESS 1 Lark-111 A010-11-03- | Z | W | N | MAX 1 X 15W

LARK-111 | EXCL** |
 LED |
 UPDATE |
 220V 240V | 50/60 Hz |
 CE |
 IP20 |
 EXCL |
 X35°Y35° |
 166 X 166 |
 1

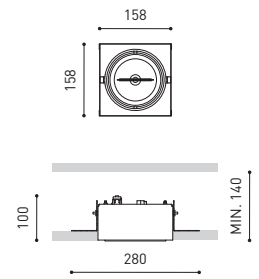

W

ORBITAL TRIMLESS 1 QR-111 A010-01-03- | Z | W | N | MAX 1 X 75W

QR-111 |
 LED | LARK-111 | 12 V | OPTIONS* |
 G53 |
 12V |
 CE |
 III |
 IP20 |
 0.5m |
 EXCL |
 X35°Y35° |
 166 X 166 |
 1

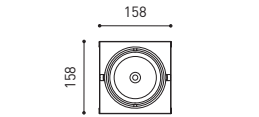

W

ORBITAL TRIMLESS 1 CDM-R111 A010-01-04- | Z | W | N | MAX 1 X 70W

CDM-R111 |
 GX8'S |
 CE |
 IP20 |
 1m |
 EXCL |
 X35°Y35° |
 166 X 166 |
 1

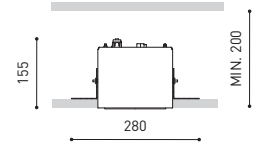

COLOUR | Z ■ | W □ | N ■ | MATERIAL | AL | i >> 452

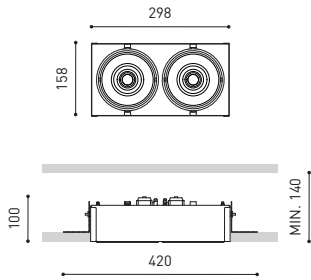

W

ORBITAL TRIMLESS 2 Lark-111

A010-12-03- | Z | W | N |

MAX 2 X 15W

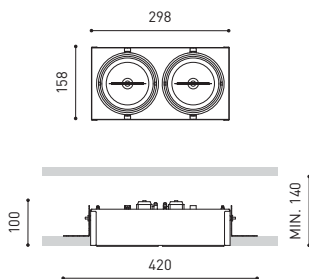

W

ORBITAL TRIMLESS 2 QR-111

A010-02-03- | Z | W | N |

MAX 2 X 75W

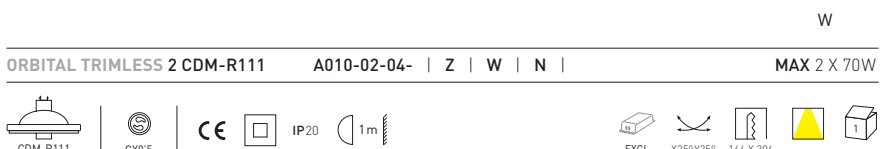
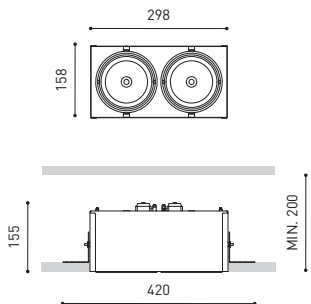

W

ORBITAL TRIMLESS 2 CDM-R111

A010-02-04- | Z | W | N |

MAX 2 X 70W



* LARK 111 | 12V  & ** LARK 111 OPTIONS » 453 |  » 468





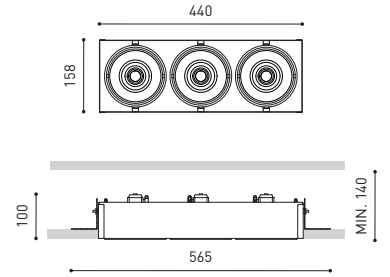

W

ORBITAL TRIMLESS 3 Lark-111 A010-13-06- | Z | W | N | MAX 3 X 15W

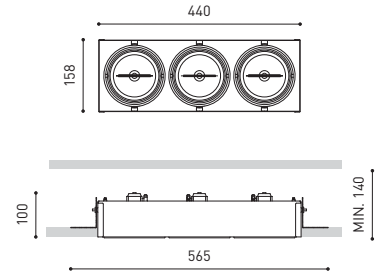

W

ORBITAL TRIMLESS 3 QR-111 A010-03-06- | Z | W | N | MAX 3 X 75W



W

ORBITAL TRIMLESS 3 Combi A010-03-02- | Z | W | N | MAX 2 X 75W | MAX 1 X 70W

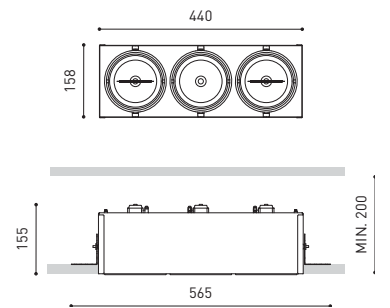
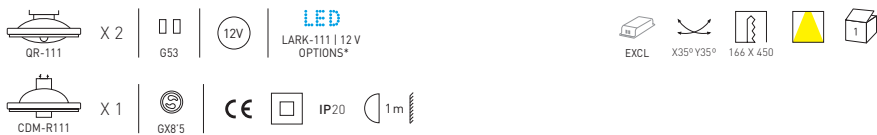

COLOUR | Z ■ | W □ | N ■ |

MATERIAL | AL | ⓘ > 452

* LARK 111 | 12V & ** LARK 111 OPTIONS > 453 | ⓘ > 468

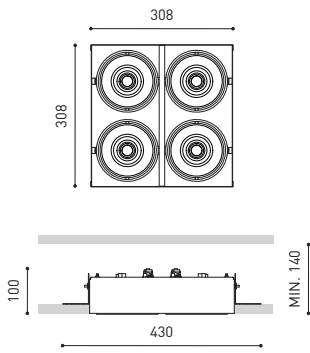

W

ORBITAL TRIMLESS 4 Lark-111

A010-14-02- | Z | W | N |

MAX 4 X 15W

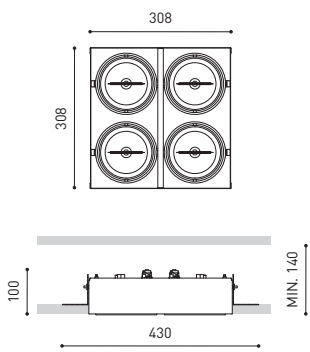

W

ORBITAL TRIMLESS 4 QR-111

A010-04-02- | Z | W | N |

MAX 4 X 75W



All LOOK Trimless - Box included

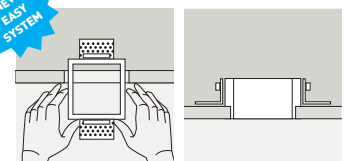

TRIMLESS MOUNTING » 464





NEW

ORBITAL MINI

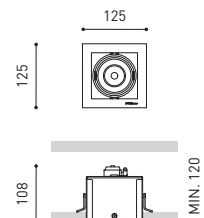

W

ORBITAL MINI 1 Lark A196-11-00- | W | N | Z | MAX 1 X 11W

W

ORBITAL MINI 1 12V A196-12-00- | W | N | Z | MAX 1 X 50W

W

ORBITAL MINI 1 230V A196-13-00- | W | N | Z | MAX 1 X 50W

COLOUR | W | N | Z

MATERIAL | AL

* LARK OPTIONS » 452 | » 468



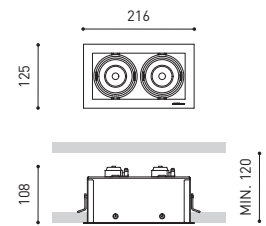

W

ORBITAL MINI 2 Lark | A196-21-00- | W | N | Z | | **MAX 2 X 11W**

W

ORBITAL MINI 2 12V | A196-22-00- | W | N | Z | | **MAX 2 X 50W**

W

ORBITAL MINI 2 230V | A196-23-00- | W | N | Z | | **MAX 2 X 50W**

COLOUR | W | N | Z |

MATERIAL | AL |

* LARK OPTIONS » 452 | » 468



Photography: Jesús Granada - Fotógrafo - www.jesusgranada.com

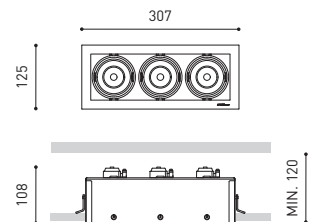

W

ORBITAL MINI 3 Lark | A196-31-00- | W | N | Z | | **MAX 3 X 11W**



W

ORBITAL MINI 3 12V | A196-32-00- | W | N | Z | | **MAX 3 X 50W**



W

ORBITAL MINI 3 230V | A196-33-00- | W | N | Z | | **MAX 3 X 50W**



COLOUR | W □ | N ■ | Z ■ |

MATERIAL | AL |

* LARK OPTIONS » 452 | » 468



ARKOS

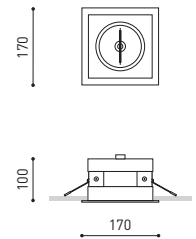

W

ARKOS 1 QR-111 2301-01-00- | Z | W | N | MAX 1 X 75W



W

ARKOS 1 CDM-R111 2302-01-00- | Z | W | N | MAX 1 X 70W

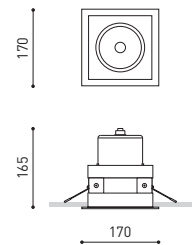

COLOUR | Z ■ | W □ | N ■ |

MATERIAL | AL |

* LARK 111 | 12V » 453 | » 468





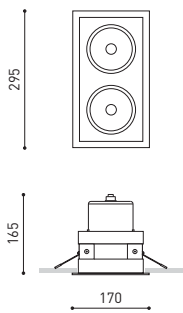
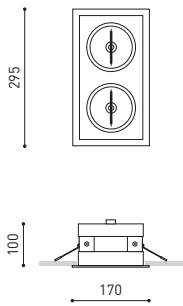

W

ARKOS 2 QR-111 2301-02-00- | Z | W | N | **MAX 2 X 75W**



W

ARKOS 2 CDM-R111 2302-02-00- | Z | W | N | **MAX 2 X 70W**



COLOUR | Z ■ | W □ | N ■ |

MATERIAL | AL |

* LARK 111 | 12V  >> 453  >> 468

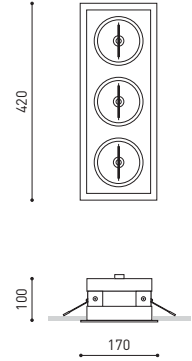

W

ARKOS 3 QR-111 2301-03-00- | Z | W | N | MAX 3 X 75W

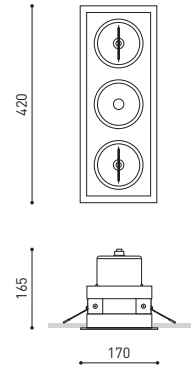

W

ARKOS 3 Combi 2302-03-12- | Z | W | N | MAX 2 X 75W | MAX 1 X 70W

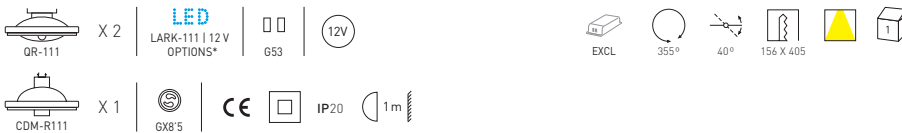

COLOUR | Z ■ | W □ | N ■ |

MATERIAL | AL |

* LARK 111 | 12V » 453 | » 468



W

ARKOS 4 QR-111

2301-04-00- | Z | W | N |

MAX 4 X 75W

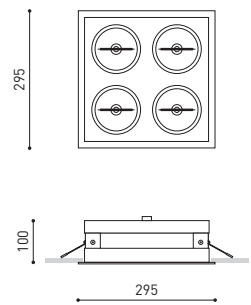

COLOUR | Z ■ | W □ | N ■ |

MATERIAL |  AL |

* LARK 111 | 12V  » 453 |  » 468

ARKOS TRIMLESS

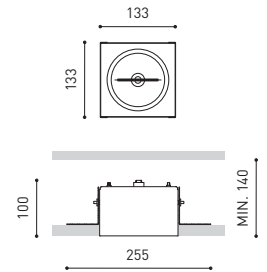

W

ARKOS TRIMLESS 1 QR-111 2301-11-00- | W | N | MAX 1 X 75W

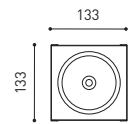

W

ARKOS TRIMLESS 1 CDM-R111 2302-11-00- | W | N | MAX 1 X 70W

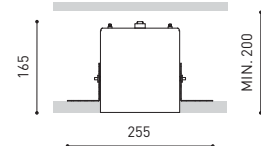

Box included

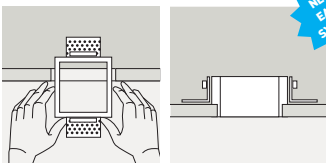

NEW
EASY
SYSTEM

COLOUR | W □ | N ■ |

MATERIAL | AL |

* LARK 111 | 12V  » 453 |  » 468

TRIMLESS MOUNTING » 464



Photography: Héctor Rubio | www.images-positive.com

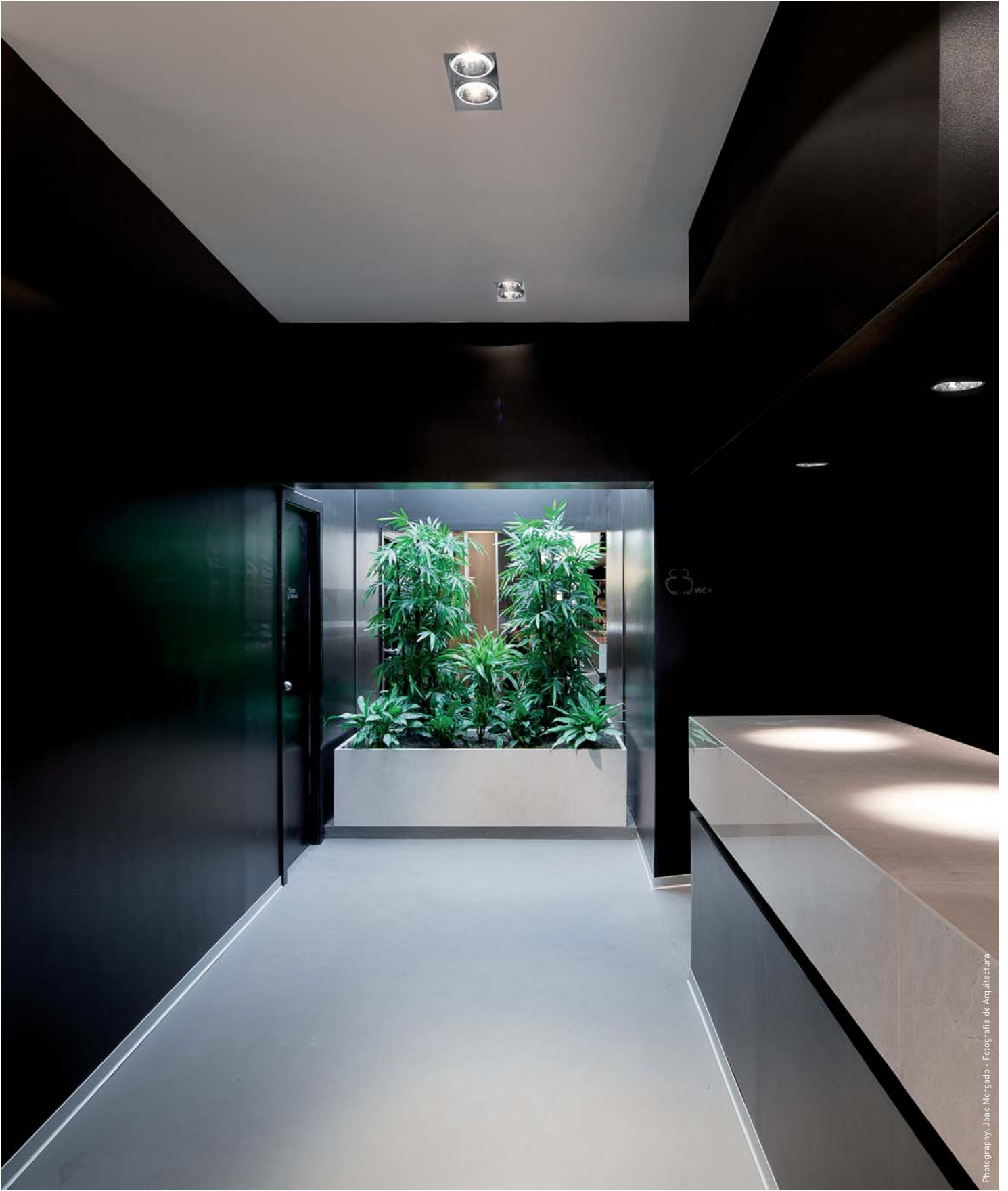

Photography: Joao Morgado - Fotografia de Arquitectura

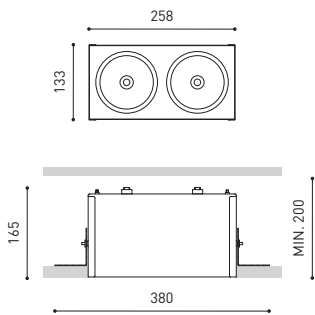
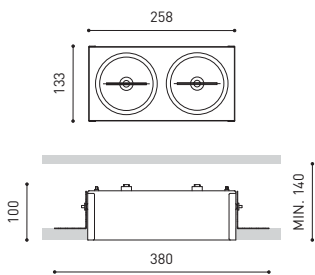

W

ARKOS TRIMLESS 2 QR-111 2301-12-00- | W | N | **MAX 2 X 75W**



W

ARKOS TRIMLESS 2 CDM-R111 2302-12-00- | W | N | **MAX 2 X 70W**

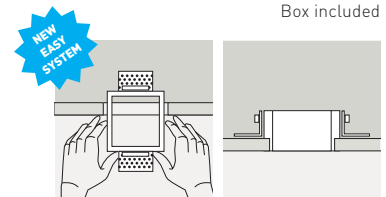

COLOUR | W □ | N ■ |

MATERIAL | AL |

* LARK 111 | 12V >> 453 | >> 468

TRIMLESS MOUNTING >> 464



Photography: Héctor Rubio | www.images-positive.com

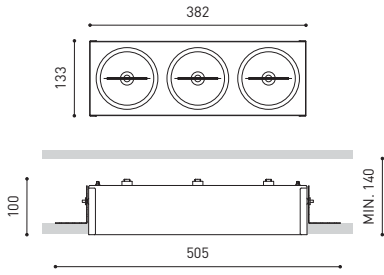

W

ARKOS TRIMLESS 3 QR-111

2301-13-00- | W | N |

MAX 3 X 75W

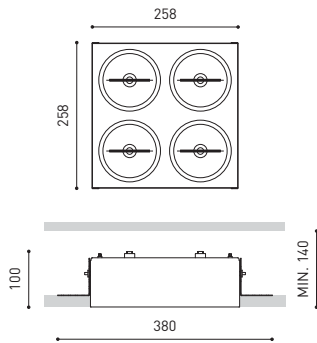

W

ARKOS TRIMLESS 4 QR-111

2301-14-00- | W | N |

MAX 4 X 75W



Box included

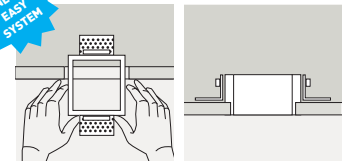

COLOUR | W □ | N ■ |

MATERIAL | AL |

* LARK 111 | 12V  » 453 |  » 468

TRIMLESS MOUNTING » 464

NEW

HIDDEN



		W	K	mA	Lm	%Eff
HIDDEN LED 1	A200-11- ☉ -1- WT NT	12W	3000K	350	1400	90%
	A200-11- ☉ -2- WT NT	12W	4000K	350	1500	90%
HIDDEN LED 2	A200-21- ☉ -1- WT NT	18W	3000K	500	1850	90%
	A200-21- ☉ -2- WT NT	18W	4000K	500	1950	90%
HIDDEN LED 2 DIM	A200-22- ☉ -1- WT NT	18W	3000K	500	1850	90%
	A200-22- ☉ -2- WT NT	18W	4000K	500	1950	90%

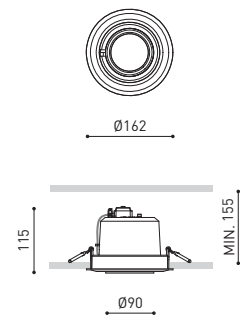

☉ BEAM OPTIONS

1	16°
2	24°
3	42°



FOOD FILTER OPTIONS

	Bread	0700-07-01
	Meat	0700-07-02
	Fish	0700-07-03

FILTER OPTIONS

	Red	0702-01-01
	Blue	0702-01-02
	Green	0702-01-03
	Orange	0702-01-04
	Yellow	0702-01-05

COLOUR | WT | NT |

MATERIAL | AL | GL-TRANS |

>> 452 | >> 468











W

HIDDEN HIT

A201-00- ☉ -0- | WT | NT |

MAX 70W



IP20



☉ BEAM OPTIONS

1	14°
2	30°
3	40°

FOOD FILTER OPTIONS

	Bread	0700-07-01
	Meat	0700-07-02
	Fish	0700-07-03

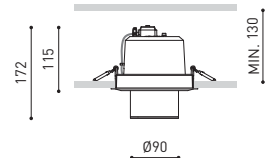

COLOUR | WT □ | NT ■ |

MATERIAL | AL | GL-TRANS | » 452

NEW

POINT 220

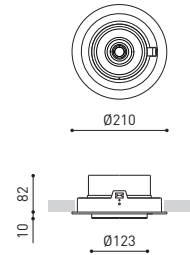

W

POINT P220 **Lark-111**

REFERENCE PLEASE CONSULT

MAX 1 X 15W

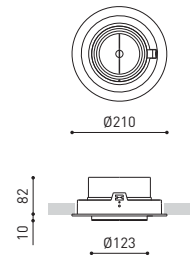

W

POINT P220 **QR-111**

2602-00-00- | Z | W |

MAX 50W



COLOUR | Z ■ | W □ |

MATERIAL | AL | >> 452

* LARK 111 | 12V & ** LARK 111 OPTIONS >> 453 | >> 468

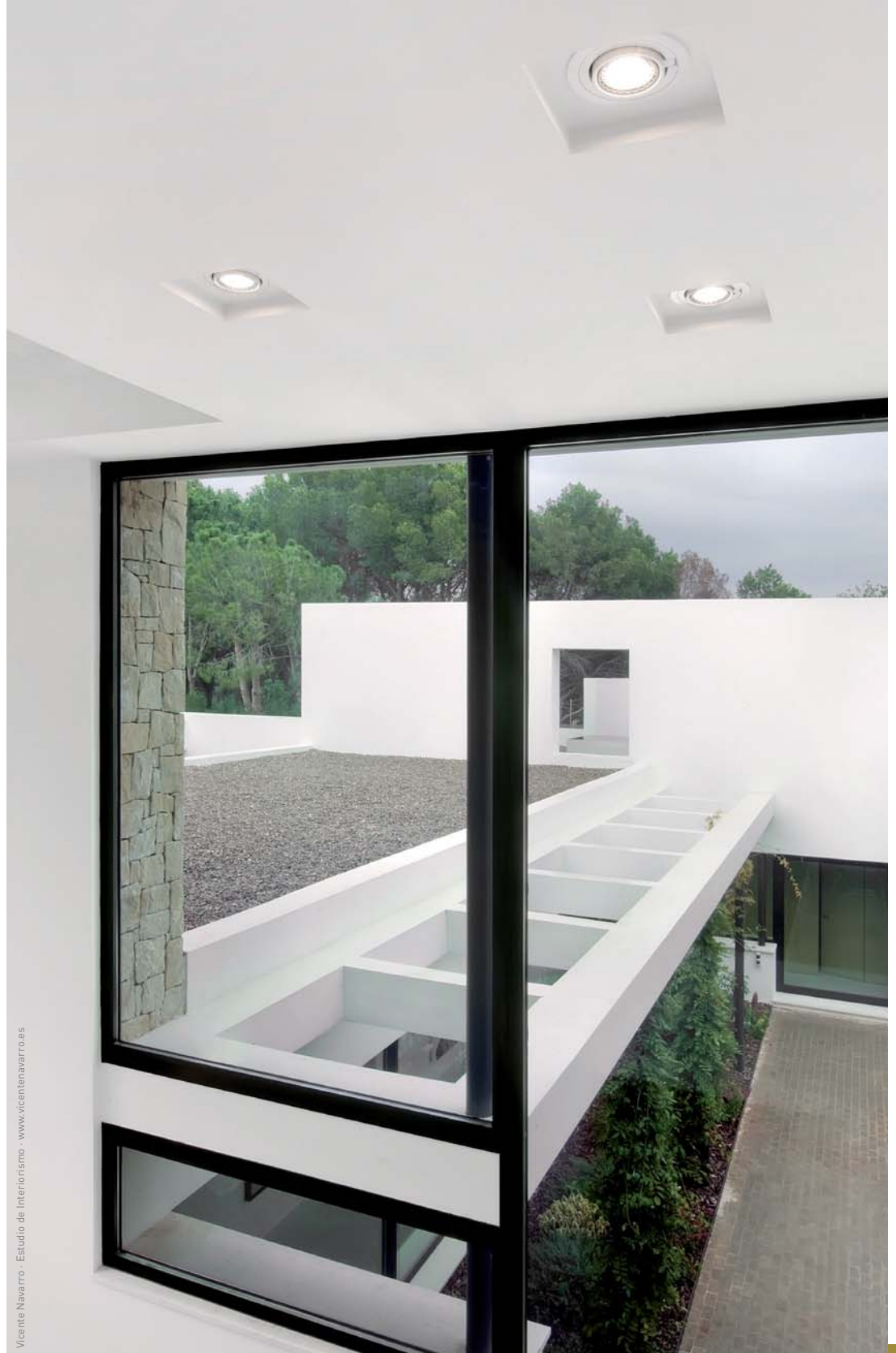







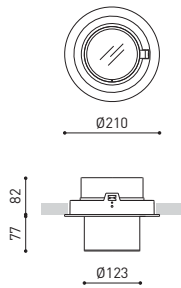

		BEAM	W
POINT P220 G12	2602-92-00- Z W	14°	MAX 150W
	2602-91-00- Z W	49°	MAX 150W



FOOD FILTER OPTIONS

	Bread	0700-01-01
	Meat	0700-01-02
	Fish	0700-01-03

		W
POINT P220 CDM-R111	2602-10-00- Z W	MAX 70W



COLOUR | Z ■ | W □ |

MATERIAL | AL | » 452



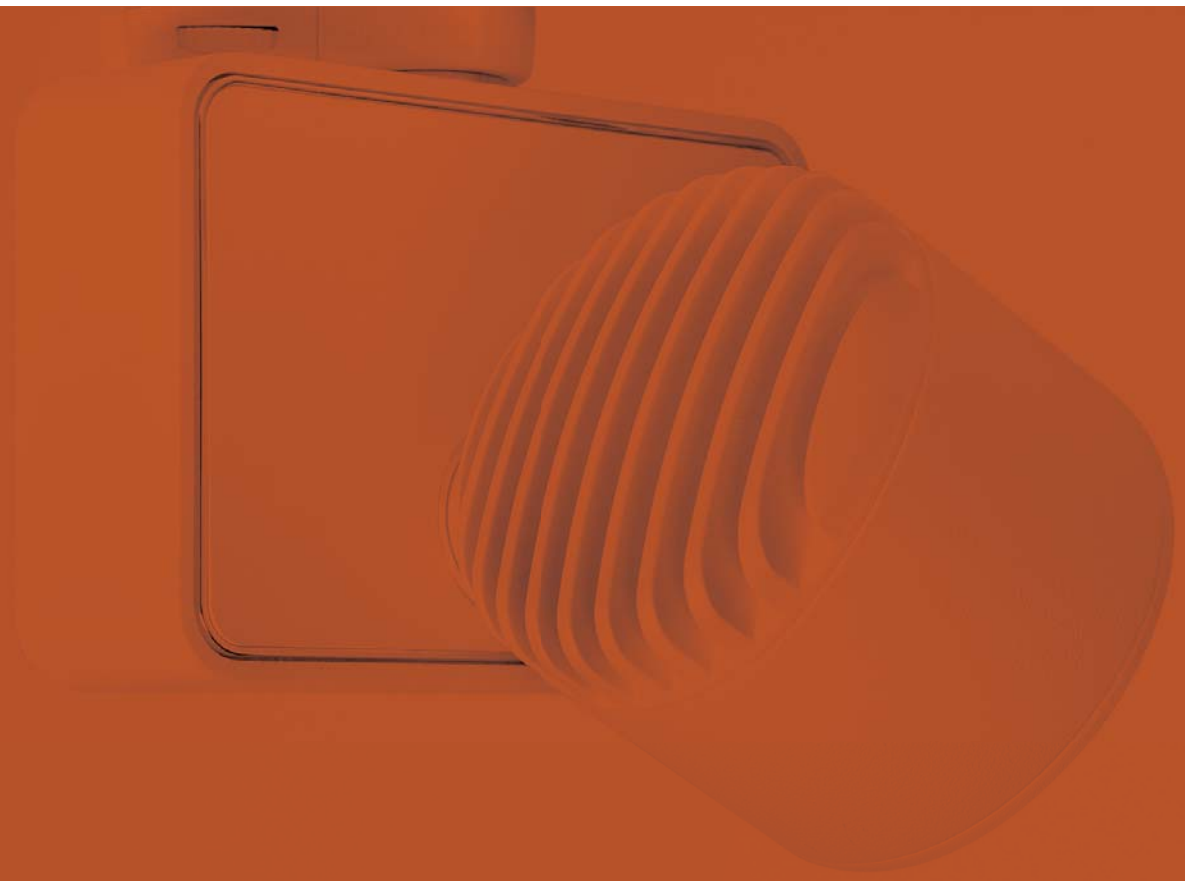

track lights





ZEN 224

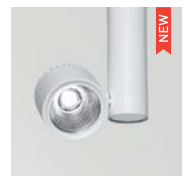

ZEN TUBE TRACK 238



KON 240



MOVE 248

ZEN

NEW



		W	K	mA	Lm	%Eff
ZEN LED 1	A183-01- ☉ -1- WT NT	12W	3000K	350	1400	90%
	A183-01- ☉ -2- WT NT	12W	4000K	350	1500	90%
ZEN LED 2	A183-02- ☉ -1- WT NT	18W	3000K	500	1850	90%
	A183-02- ☉ -2- WT NT	18W	4000K	500	1950	90%
ZEN LED 3	A183-03- ☉ -1- WT NT	21,5W	3000K	640	2550	90%
	A183-03- ☉ -2- WT NT	21,5W	4000K	640	2650	90%



☉ BEAM OPTIONS

1	16°
2	24°
3	42°

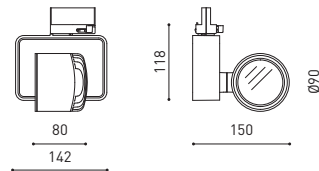

COLOUR | WT □ | NT ■ |

MATERIAL | AL | GL-TRANS | TRACK OPTIONS >> 256

ⓘ >> 452 | ⓘ >> 468







COVER OPTIONS

	Walnut	0702-00-01
	Iroko	0702-00-02
	Ash	0702-00-03

FOOD FILTER OPTIONS

	Bread	0700-07-01
	Meat	0700-07-02
	Fish	0700-07-03

FILTER OPTIONS

	Red	0702-01-01
	Blue	0702-01-02
	Green	0702-01-03
	Orange	0702-01-04
	Yellow	0702-01-05

ZEN Surface Adapter

0000-55-43- | W |

0000-55-39- | N |



ZEN Recessed Adapter

0000-55-44- | W |

0000-55-40- | N |











Photography: Jonathan Martín Fotógrafo - Insitu 2000 Arquitectura, Etnia Madrid | www.jonathanhmartin.es















W*

ZEN HIT	A185-01- -0- WT NT	35W
	A185-02- -0- WT NT	70W



BEAM OPTIONS

1	14°
2	30°
3	40°

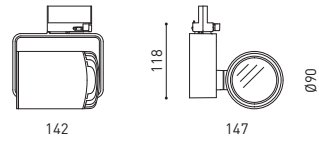

FOOD FILTER OPTIONS

	Bread	0700-07-01
	Meat	0700-07-02
	Fish	0700-07-03

ZEN Surface Adapter	0000-55-43- W	ZEN Recessed Adapter	0000-55-44- W
	0000-55-39- N		0000-55-40- N



COLOUR | WT | NT | MATERIAL | AL | GL-TRANS | TRACK OPTIONS » 256 * 20W & 50W PLEASE CONSULT » 452



Photography: Jesús Granada · Fotógrafo · www.jesusgranada.com

NEW

ZEN TUBE TRACK



		W	K	mA	Lm	%Eff
ZEN TUBE TRACK 1	A184-21- ☉ -1- WT NT	12W	3000K	350	1400	90%
	A184-21- ☉ -2- WT NT	12W	4000K	350	1500	90%
ZEN TUBE TRACK 2	A184-22- ☉ -1- WT NT	18W	3000K	500	1850	90%
	A184-22- ☉ -2- WT NT	18W	4000K	500	1950	90%
ZEN TUBE TRACK 3	A184-23- ☉ -1- WT NT	21,5W	3000K	640	2550	90%
	A184-23- ☉ -2- WT NT	21,5W	4000K	640	2650	90%



50/60 Hz



IP20 | CRI>80



☉ BEAM OPTIONS

1	16°
2	24°
3	42°

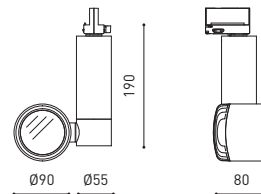

ZEN Surface Adapter

0000-55-43- | W |

0000-55-39- | N |



ZEN Recessed Adapter

0000-55-44- | W |

0000-55-40- | N |

COLOUR | WT | NT |

MATERIAL | AL | GL-TRANS | TRACK OPTIONS » 256



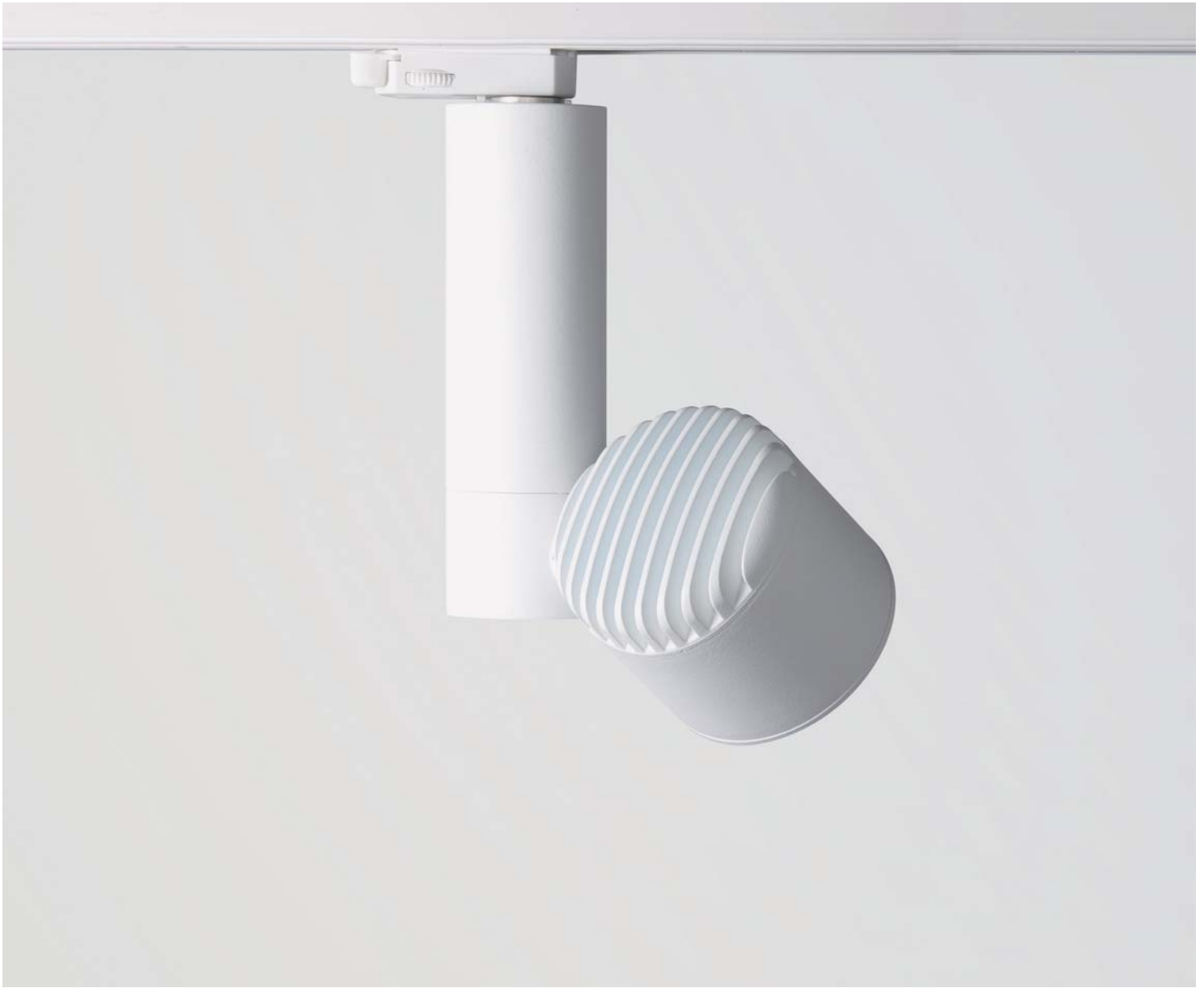

i » 452 | **U** » 468



FOOD FILTER OPTIONS

	Bread	0700-07-01
	Meat	0700-07-02
	Fish	0700-07-03

FILTER OPTIONS

	Red	0702-01-01
	Blue	0702-01-02
	Green	0702-01-03
	Orange	0702-01-04
	Yellow	0702-01-05

NEW

KON

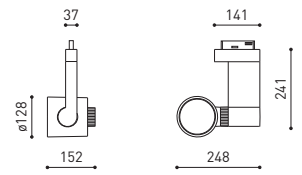

W

KON Lark-111

REFERENCE PLEASE CONSULT

MAX 1 X 15W

LARK-111 | INCL* |
 LED |
 UPDATE |
 220V/240V |
 50/60 Hz |
 CE |
 IP20 |
 CRI>80 |
 INCL | ELEC |
 FAST | CONNEX |
 EURO ADAPT |
 355° |
 350° |

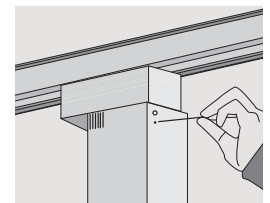

Individual internal potentiometer

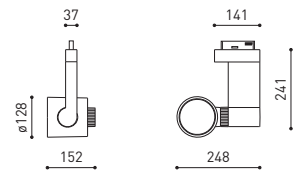

W

KON QR-111

2534-70-00- | Z | W |

MAX 100W

QR-111* |
 G53 |
 220V/240V |
 50/60 Hz |
 CE |
 IP20 |
 1m |
 PHASE CUT** |
 INCL | ELEC |
 EURO ADAPT |
 355° |
 350° |

COLOUR | Z ■ | W □ |

MATERIAL | AL | TRACK OPTIONS >> 256

* LARK 111 OPTIONS >> 453 >> 468

** ONLY TRAILING EDGE | >> 452





Sala d'exposicions Josep Rinau - Facultat de Belles Arts, UPV | Autors: Pep Carrió - Isidre Ferrer

PENSAR CON LAS MANOS

PEP
CARRIÓ
& ISIDRO
FERRER

31.05.2013.
05.07.2013
Sala d'exposicions
Josep Renau
Facultat de Belles
Arts - UPV



Exposició itinerària amb
sigil·la d'acreditació, atenció
al client i una gran qualitat
multimedial.





		W
KON CDM-R111	2539-70-35- Z W	35W
	2539-70-07- Z W	70W



		W
KON PAR 30	2536-70-00- Z W	100W

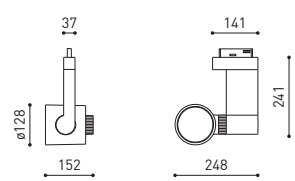

COLOUR | Z ■ | W □ |

MATERIAL | AL | TRACK OPTIONS » 256

» 452



Photography: Joao Morgado - Fotografia de Arquitectura



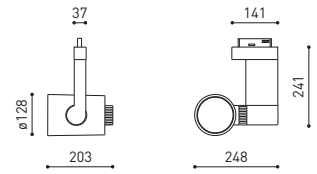

		BEAM	W
KON G12	2538-71-07- Z W	56°	70W
	2538-71-15- Z W	56°	150W
	2538-72-07- Z W	33°	70W
	2538-72-15- Z W	33°	150W



GL-TRANS

FOOD FILTER OPTIONS

	Bread	0700-02-01
	Meat	0700-02-02
	Fish	0700-02-03

		W
KON P30 CDM-R	2537-70-35- Z W	35W
	2537-70-07- Z W	70W



COLOUR | Z ■ | W □

MATERIAL | AL | TRACK OPTIONS » 256

» 452



MOVE

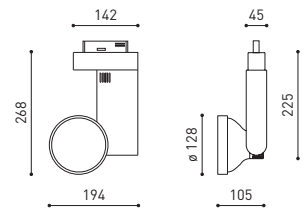

W

MOVE QR-111 2502-71-10- | Z | W | MAX 100W

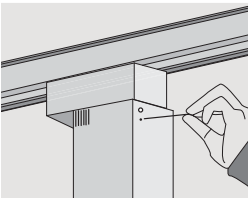

Individual internal potentiometer

W

MOVE CDM-R111 2542-71-35- | Z | W | 35W
 2542-71-07- | Z | W | 70W



COLOUR | Z ■ | W □ |

MATERIAL | AL | TRACK OPTIONS » 256

* LARK 111 OPTIONS » 453 | » 468

** ONLY TRAILING EDGE | » 452

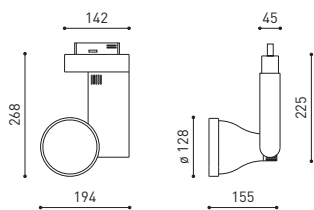

		BEAM	W
MOVE G12	2582-71-35- Z W	89°	35W
	2582-71-07- Z W	89°	70W
	2582-71-15- Z W	89°	150W
	2582-72-35- Z W	10°	35W
	2582-72-07- Z W	10°	70W
	2582-72-15- Z W	10°	150W



FOOD FILTER OPTIONS

	Bread	0700-03-01
	Meat	0700-03-02
	Fish	0700-03-03

		W
MOVE P30 CDM-R	2562-71-35- Z W	35W
	2562-71-07- Z W	70W

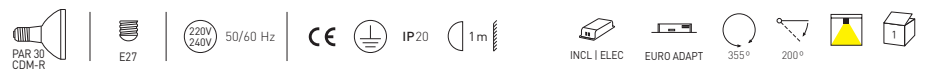

COLOUR | Z ■ | W □ |

MATERIAL | AL | TRACK OPTIONS » 256

» 452





Photography: James Silverman · www.jamessilverman.co.uk



W

MOVE PAR 30

2562-71-00- | Z | W |

MAX 100W



PAR 30



E27



220V
240V

50/60 Hz



IP20



1m



EURO ADAPT



355°



200°



Warning

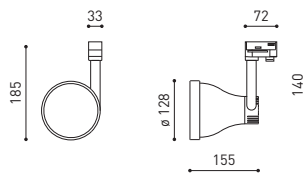

COLOUR | Z ■ | W □ |

MATERIAL |  AL | TRACK OPTIONS » 256

 » 452







TRACK 230V 3L+N SURFACE & SUSPENDED

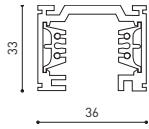

TRACK 230V 1M	2500-71-01-	B N Z
TRACK 230V 2M	2500-71-02-	B N Z
TRACK 230V 3M	2500-71-03-	B N Z

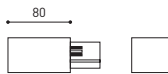

TRACK 230V Live-End Connector	2500-71-00-	B N Z
-------------------------------	-------------	-----------

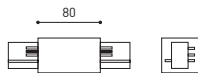

TRACK 230V Central Connector	2500-71-15-	B N Z
------------------------------	-------------	-----------



TRACK 230V Ceiling Kit	2500-71-09-	Z
------------------------	-------------	---

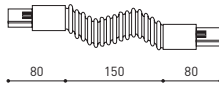

TRACK 230V Universal Angle	2500-71-07-	B N Z
----------------------------	-------------	-----------

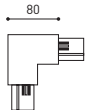

TRACK 230V 90° Angle to the Right	2500-71-08-	B N Z
-----------------------------------	-------------	-----------

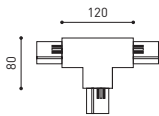

TRACK 230V T Joint	2500-71-12-	B N Z
--------------------	-------------	-----------

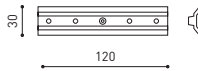

TRACK 230V Mechanical Joint	2500-71-05-	Z
-----------------------------	-------------	---



TRACK 230V Suspension Kit	2500-71-11-	Z
---------------------------	-------------	---

TRACK 230V 3L+N FLUSH MOUNTING



TRACK 230V FLUSH 1M	2500-71-21- B N Z
TRACK 230V FLUSH 2M	2500-71-22- B N Z
TRACK 230V FLUSH 3M	2500-71-23- B N Z

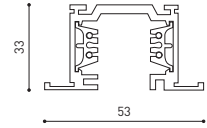

TRACK 230V FLUSH Live-End Connec	2500-71-20- B N Z
----------------------------------	-------------------------

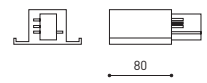

TRACK 230V FLUSH Central Connec	2500-71-10- B N Z
---------------------------------	-------------------------

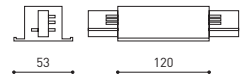

TRACK 230V FLUSH Ceiling Kit	2500-71-14
------------------------------	------------

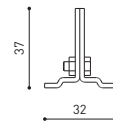

SURFACE & SUSPENDED / FLUSH MOUNTING

TRACK Contact Joint	2500-71-04- B N
---------------------	---------------------

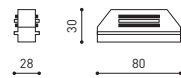

TRACK End	2500-71-06- B N Z
-----------	-------------------------

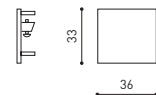

COLOUR | B □ | N ■ | Z ■ |

profiles









Photography: Héctor Rubio | www.images-positive.com



SLIMG0T 262



FORTY 266



PROFILE 035 272



PROFILE 040 280



PROFILE 140 298



PROFILE 220 316

NEW

SLIMGOT



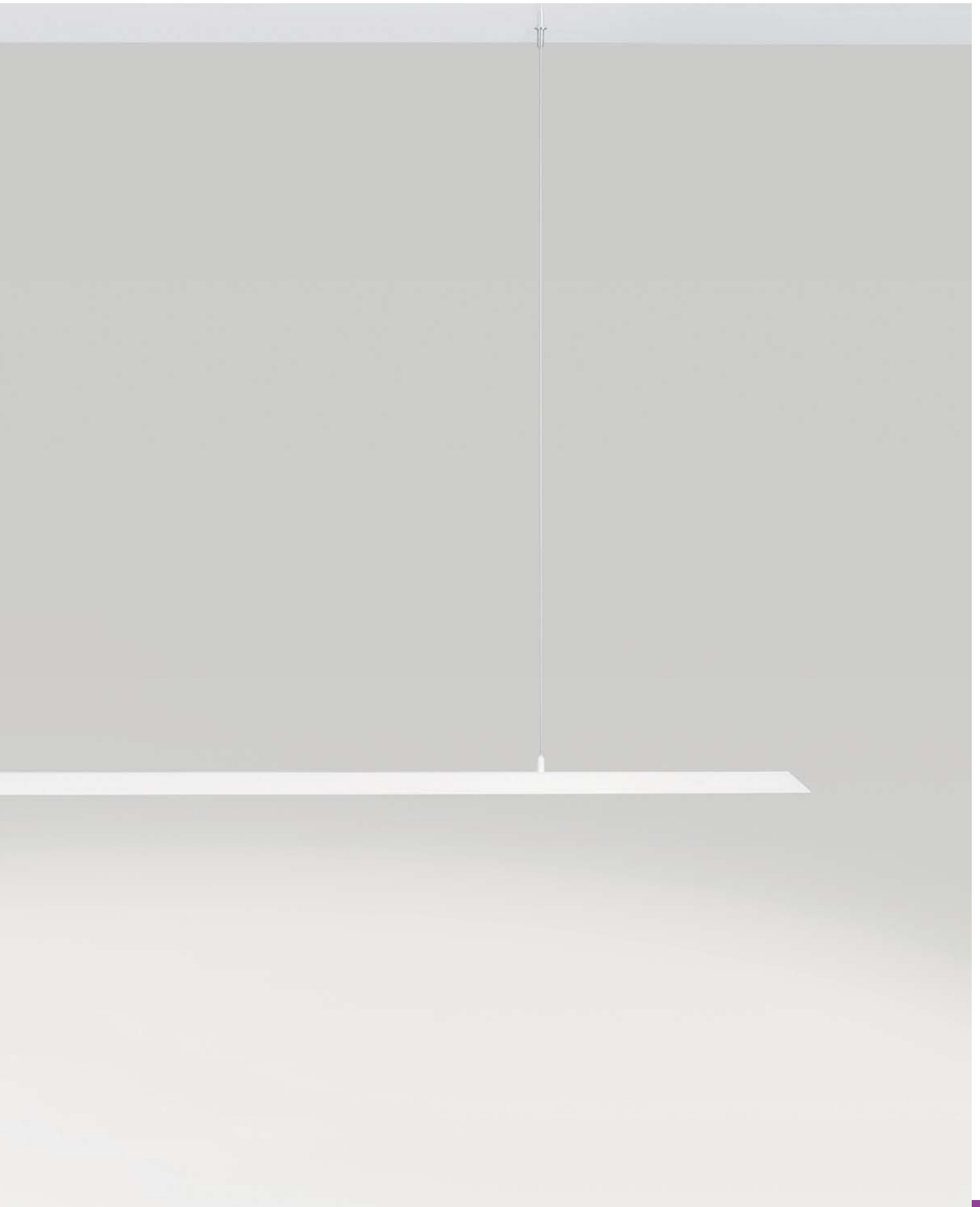



FORTIMO LED LINE by **PHILIPS**

		W	K	Lm	%Eff
SLIMGOT 120	A203-11-01- WT	18,5W	3000K	2440	85%
	A203-11-02- WT	18,5W	4000K	2600	85%
	A203-12-01- WT	18,5W	3000K	2440	85%
	A203-12-02- WT	18,5W	4000K	2600	85%

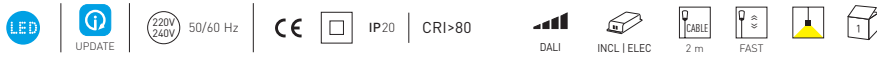

FORTIMO LED LINE by **PHILIPS**

		W	K	Lm	%Eff
SLIMGOT 150	A203-21-01- WT	23W	3000K	3025	85%
	A203-21-02- WT	23W	4000K	3250	85%
	A203-22-01- WT	23W	3000K	3025	85%
	A203-22-02- WT	23W	4000K	3250	85%

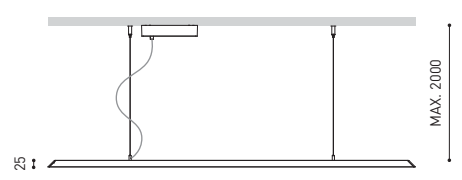
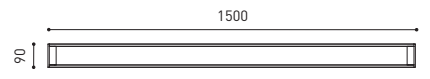
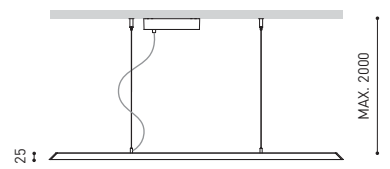
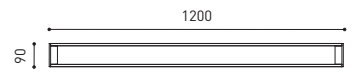
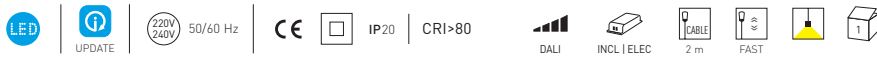

COLOUR | WT □ |

MATERIAL | AL | PMMA |

» 452 | » 468

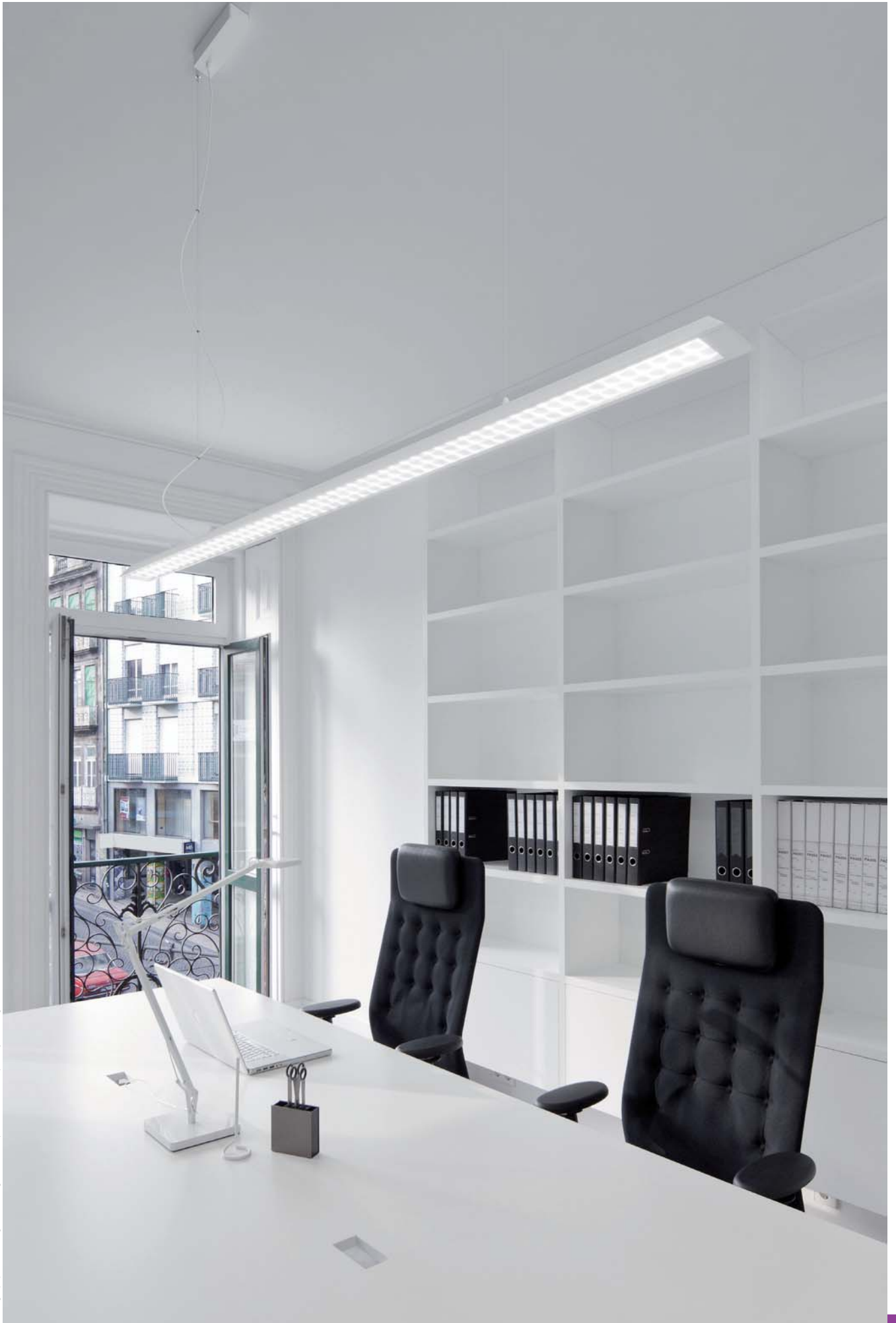

NEW

FORTY

Photography: Joao Morgado - Fotografia de Arquitectura - www.photo.joaoorgado.com



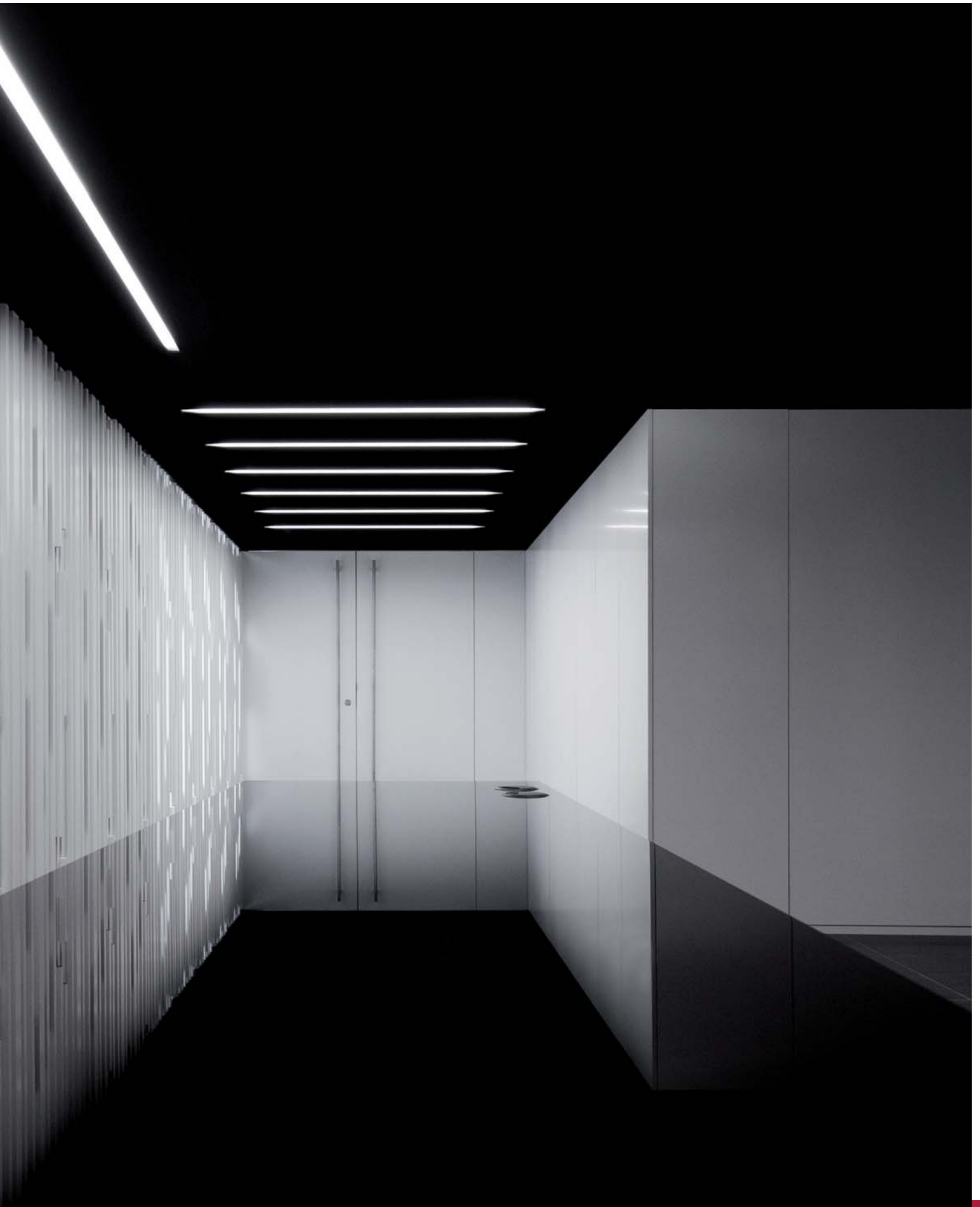

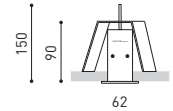

FORTY LED POWERED by TRIDONIC

		W	K	Lm		%Eff
FORTY LED 90	A205-11-01- W	18,5W	3000K	2160	50 X 910	43%
	A205-11-02- W	18,5W	4000K	2220	50 X 910	43%
FORTY LED 120	A205-21-01- W	25W	3000K	2880	50 X 1210	43%
	A205-21-02- W	25W	4000K	2960	50 X 1210	43%
	A205-22-01- W	25W	3000K	2880	50 X 1210	43%
	A205-22-02- W	25W	4000K	2960	50 X 1210	43%
FORTY LED 150	A205-31-01- W	31W	3000K	3600	50 X 1510	43%
	A205-31-02- W	31W	4000K	3700	50 X 1510	43%
	A205-32-01- W	31W	3000K	3600	50 X 1510	43%
	A205-32-02- W	31W	4000K	3700	50 X 1510	43%

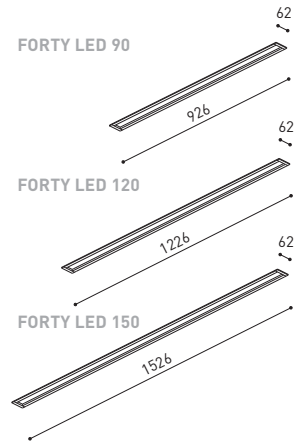

FORTY T5

		W	K	
FORTY T5 60	A206-01-01- W	24W	3000K	50 X 610
	A206-01-02- W	24W	4000K	50 X 610
	A206-02-01- W	24W	3000K	50 X 610
	A206-02-02- W	24W	4000K	50 X 610
FORTY T5 90	A206-11-01- W	39W	3000K	50 X 910
	A206-11-02- W	39W	4000K	50 X 910
	A206-12-01- W	39W	3000K	50 X 910
FORTY T5 120	A206-12-02- W	39W	4000K	50 X 910
	A206-21-01- W	54W	3000K	50 X 1210
	A206-21-02- W	54W	4000K	50 X 1210
	A206-22-01- W	54W	3000K	50 X 1210
A206-22-02- W	54W	4000K	50 X 1210	

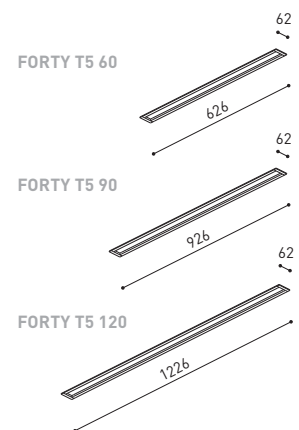
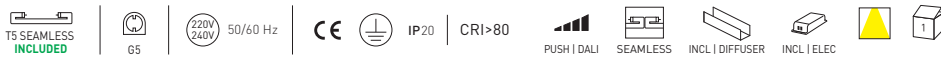

COLOUR | W □ |

MATERIAL | AL | PC |

» 452 | » 468

FORTY LED CUSTOM POWERED BY TRIDONIC

		W	K	Lm	L	%Eff
FORTY LED CUSTOM 90	A207-11- Ⓞ -1- W	18,5W	3000K	2160	900	43%
	A207-11- Ⓞ -2- W	18,5W	4000K	2220	900	43%
FORTY LED CUSTOM 120	A207-21- Ⓞ -1- W	25W	3000K	2880	1200	43%
	A207-21- Ⓞ -2- W	25W	4000K	2960	1200	43%
	A207-22- Ⓞ -1- W	25W	3000K	2880	1200	43%
	A207-22- Ⓞ -2- W	25W	4000K	2960	1200	43%
FORTY LED CUSTOM 150	A207-31- Ⓞ -1- W	31W	3000K	3600	1500	43%
	A207-31- Ⓞ -2- W	31W	4000K	3700	1500	43%
	A207-32- Ⓞ -1- W	31W	3000K	3600	1500	43%
	A207-32- Ⓞ -2- W	31W	4000K	3700	1500	43%



FORTY T5 CUSTOM

		W	K	L
FORTY T5 CUSTOM 60	A208-01- Ⓞ -1- W	24W	3000K	600
	A208-01- Ⓞ -2- W	24W	4000K	600
	A208-02- Ⓞ -1- W	24W	3000K	600
	A208-02- Ⓞ -2- W	24W	4000K	600
FORTY T5 CUSTOM 90	A208-11- Ⓞ -1- W	39W	3000K	900
	A208-11- Ⓞ -2- W	39W	4000K	900
	A208-12- Ⓞ -1- W	39W	3000K	900
	A208-12- Ⓞ -2- W	39W	4000K	900
FORTY T5 CUSTOM 120	A208-21- Ⓞ -1- W	54W	3000K	1200
	A208-21- Ⓞ -2- W	54W	4000K	1200
	A208-22- Ⓞ -1- W	54W	3000K	1200
	A208-22- Ⓞ -2- W	54W	4000K	1200



FORTY LED & T5 CUSTOM OPTIONS

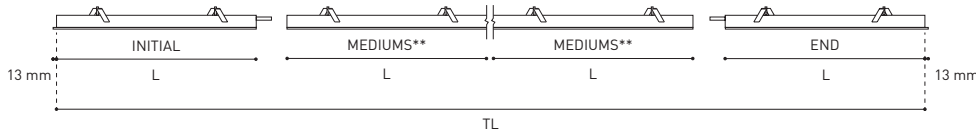

Ⓞ	ASSEMBLY POSITION
1	Initial
2	Medium
3	End

** At least one Medium unit needed.

* FORTY CUSTOM DIFFUSER	L
A209-00-60	600
A209-00-90	900
A209-01-20	1200
A209-01-50	1500
A209-01-80	1800
A209-02-10	2100
A209-02-40	2400
A209-02-70	2700
A209-03-00	3000

Add as many diffuser units to cover the TL desired



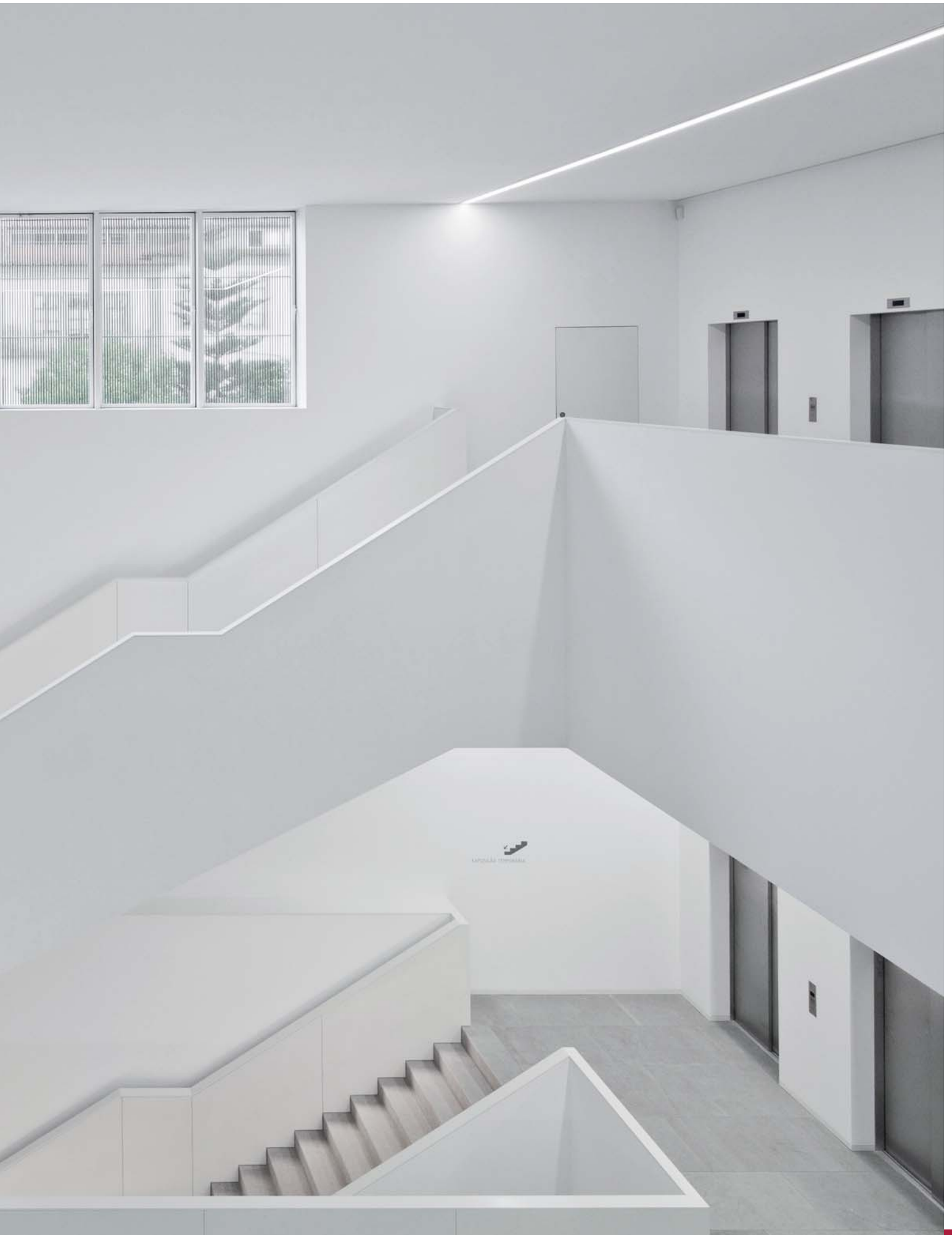

PROFILE 035



Interiorista Sebastian Ruiz Maldonado



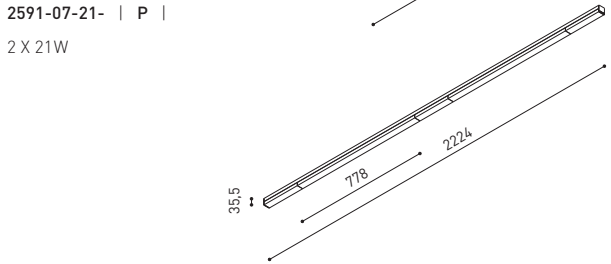
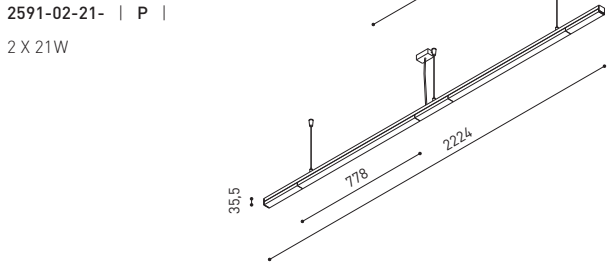
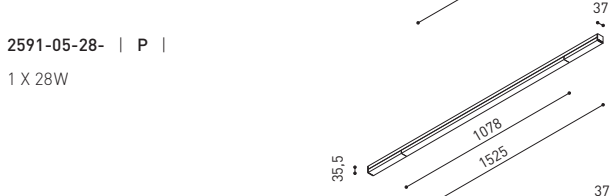
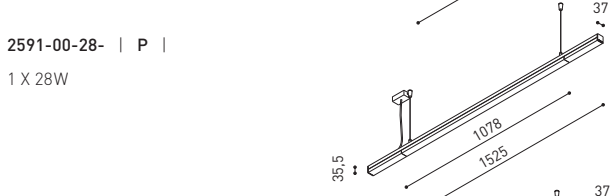
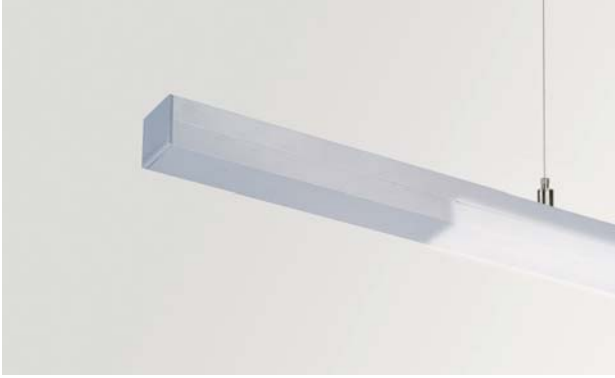

PROFILE 035 Susp



PROFILE 035 Surface



COLOUR | P ■ | MATERIAL | AL | PC | ⓘ » 452

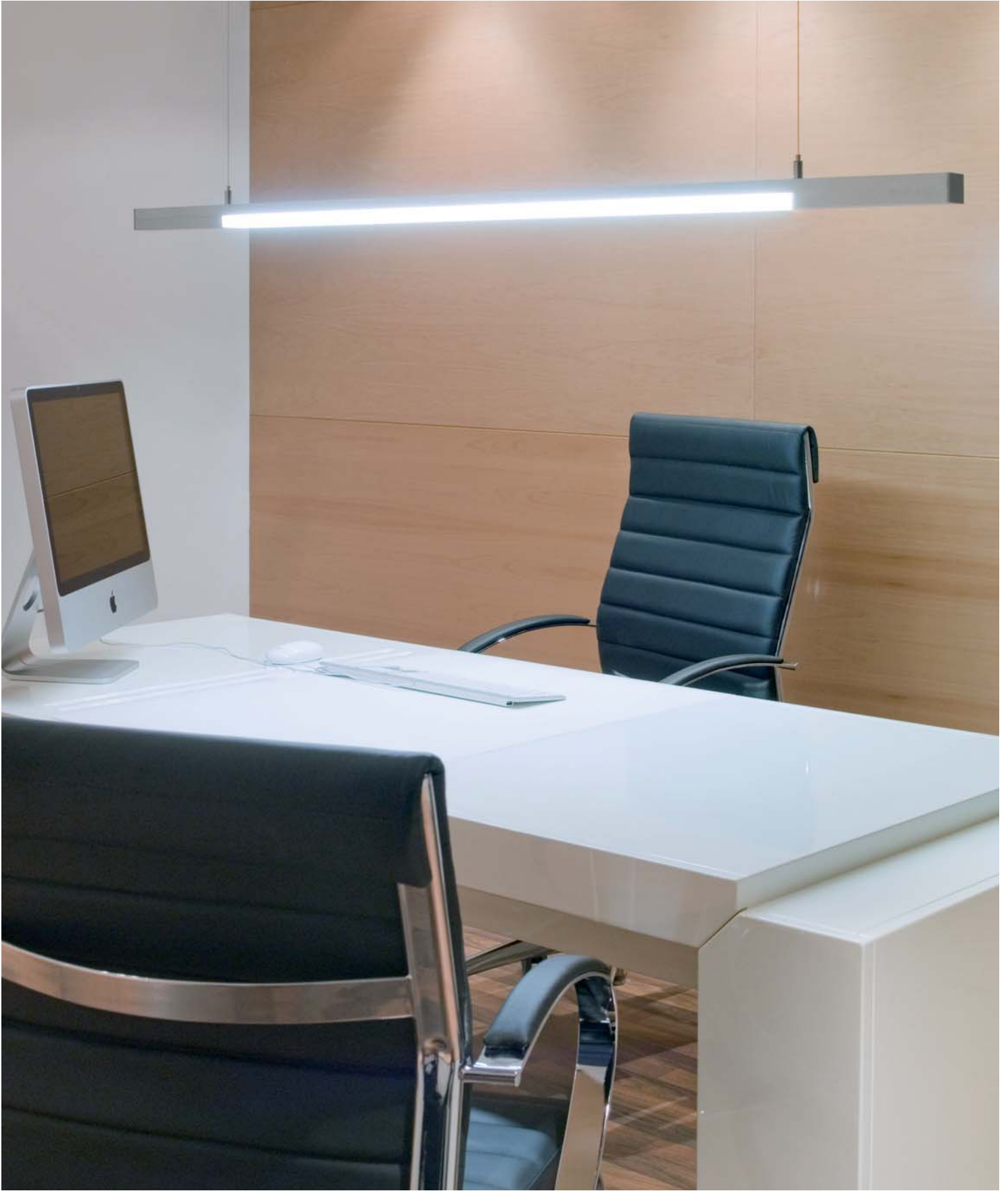









PROFILE 035 CUSTOM

PROFILE 035 Custom Initial

2591-21-01- | P |

1 X 21W

PROFILE 035 Custom Medium

2591-21-02- | P |

1 X 21W

PROFILE 035 Custom End

2591-21-03- | P |

1 X 21W

PROFILE 035 Custom Initial

2591-28-01- | P |

1 X 28W

PROFILE 035 Custom Medium

2591-28-02- | P |

1 X 28W

PROFILE 035 Custom End

2591-28-03- | P |

1 X 28W

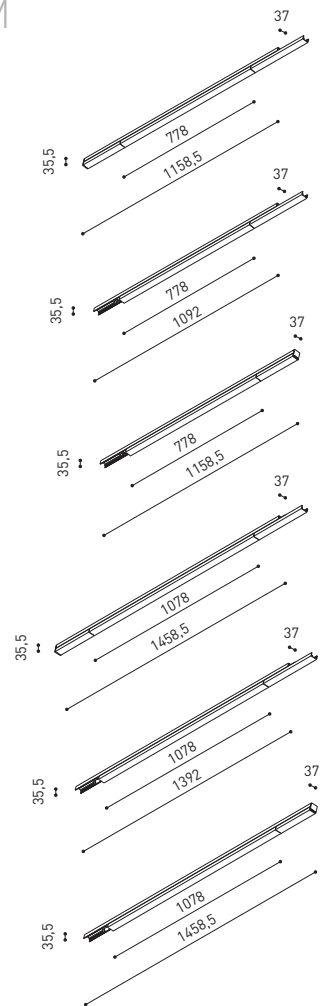

PROFILE 035 Custom



COLOUR | P ■ |

MATERIAL | AL | PC |

i » 452

PROFILE 040



| P |

| W |

| N |

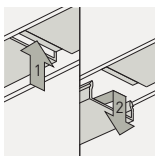

Easy diffuser removal



Liana Invest - Project: Vicente Navarro - 17/1/2010







2594-00-39- | P | W | N |
1 X 39W

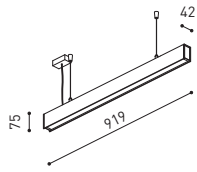

2594-00-54- | P | W | N |
1 X 54W

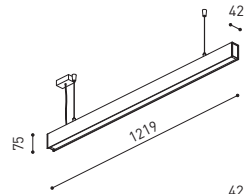

2594-00-80- | P | W | N |
1 X 80W

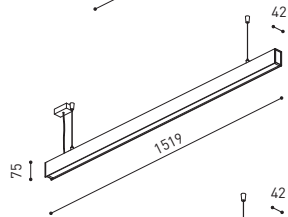

2594-02-39- | P | W | N |
2 X 39W

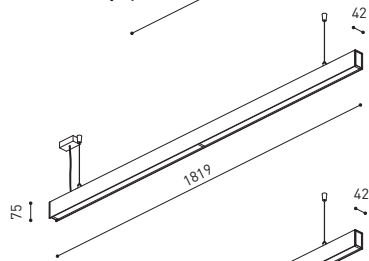

2594-02-54- | P | W | N |
2 X 54W

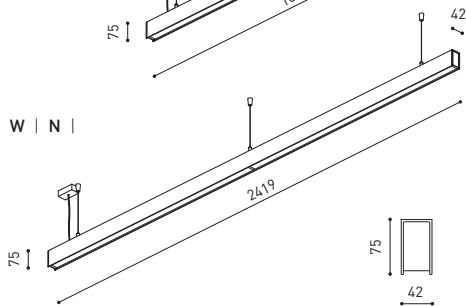

PROFILE 040 Susp



COLOUR | P ■ | W □ | N ■ | MATERIAL | AL | PC |



2594-00-39- | LP | LW | LN |
1 X 39W

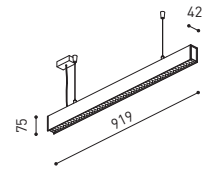

2594-00-54- | LP | LW | LN |
1 X 54W

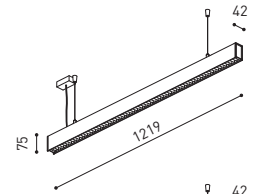

2594-00-80- | LP | LW | LN |
1 X 80W

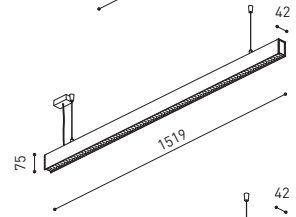

2594-02-39- | LP | LW | LN |
2 X 39W

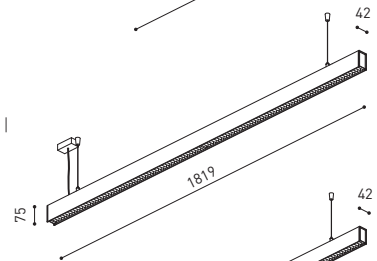

2594-02-54- | LP | LW | LN |
2 X 54W

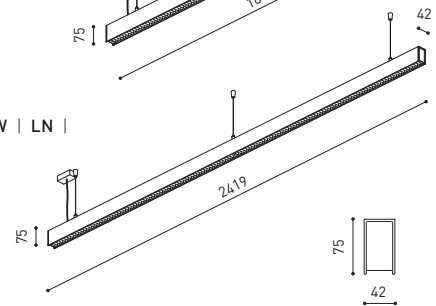

PROFILE 040 Susp Louver



COLOUR | LP ■ | LW □ | LN ■ | MATERIAL | AL | » 394

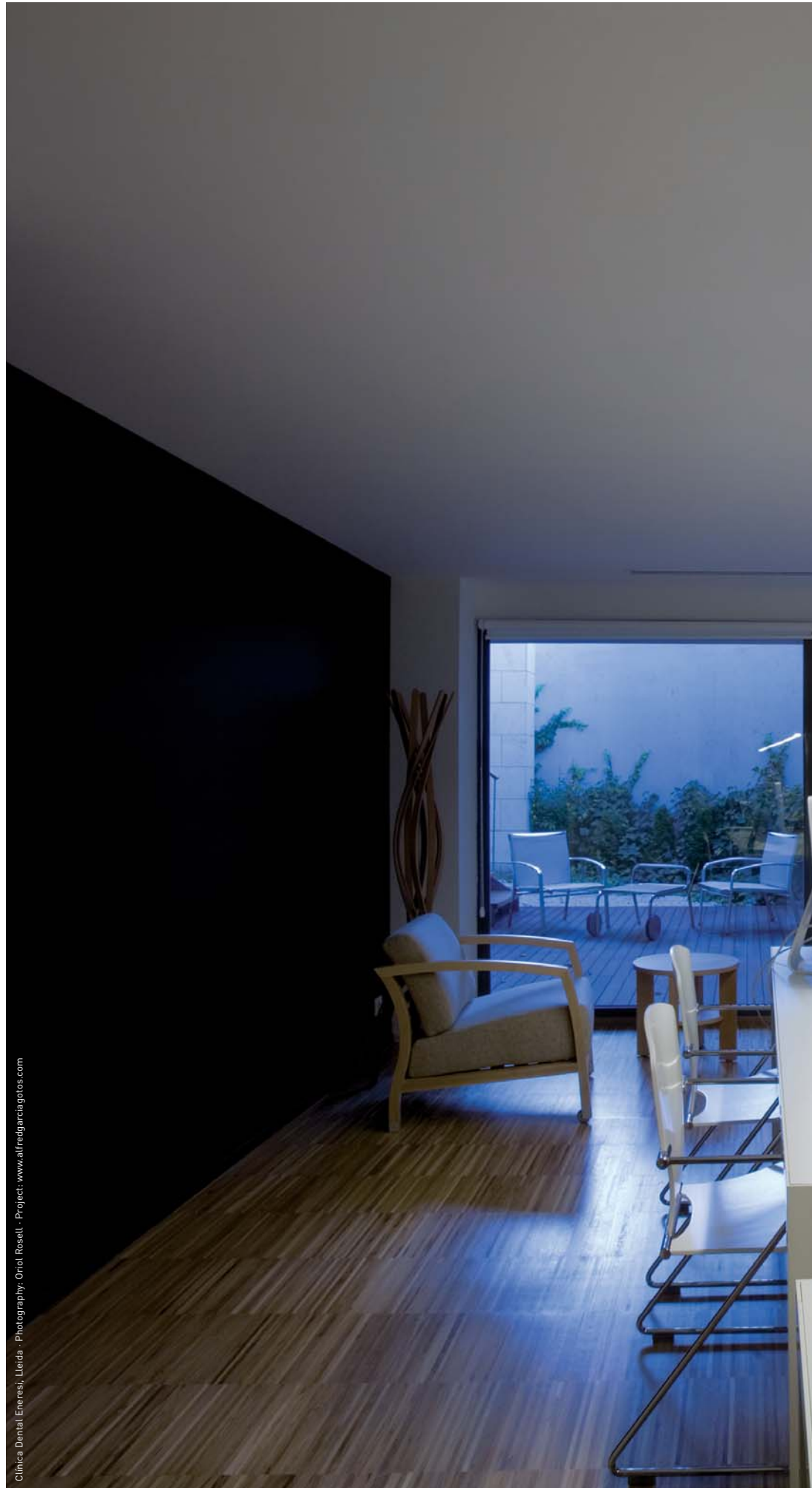

Clinica Dental Etxepesi, Lleida - Photography: Oriol Rosell - Project: www.alredgarciaiglesias.com







2594-25-39- | P | W | N |
1 X 39W

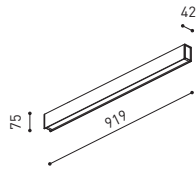

2594-25-39- | LP | LW | LN |
1 X 39W

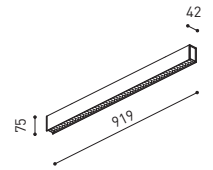

2594-25-54- | P | W | N |
1 X 54W

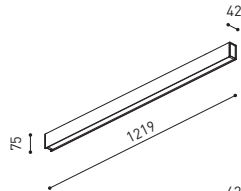

2594-25-54- | LP | LW | LN |
1 X 54W

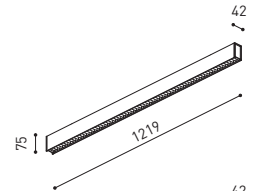

2594-25-80- | P | W | N |
1 X 80W

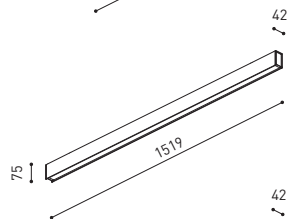

2594-25-80- | LP | LW | LN |
1 X 80W

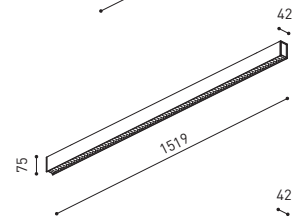

2594-27-39- | P | W | N |
2 X 39W

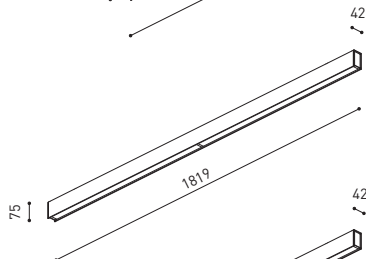

2594-27-39- | LP | LW | LN |
2 X 39W

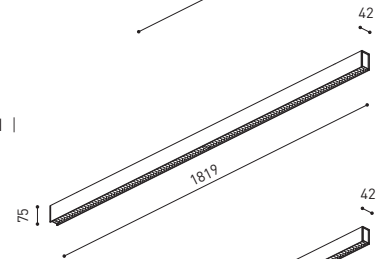

2594-27-54- | P | W | N |
2 X 54W

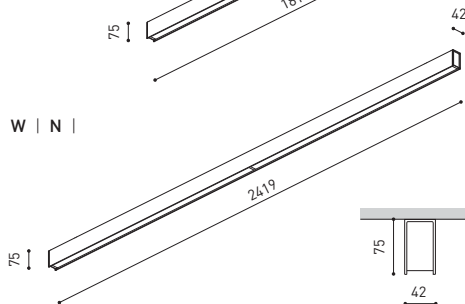

2594-27-54- | LP | LW | LN |
2 X 54W

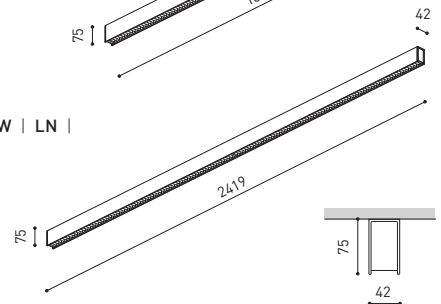

PROFILE 040 Surface



COLOUR | P ■ | W □ | N ■ | MATERIAL | AL | PC |

PROFILE 040 Surface Louver



COLOUR | LP ■ | LW □ | LN ■ | MATERIAL | AL | » 394







2594-20-39- | P | W | N |
1 X 39W

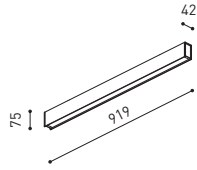

2594-20-54- | P | W | N |
1 X 54W

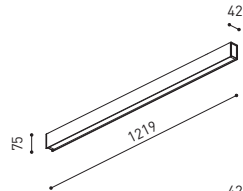

2594-20-80- | P | W | N |
1 X 80W

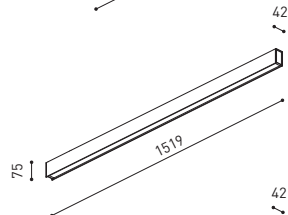

2594-22-39- | P | W | N |
2 X 39W

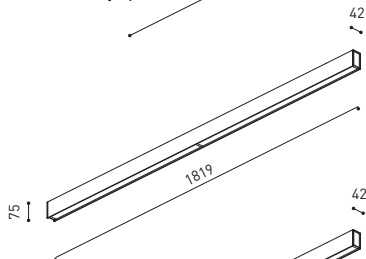

2594-22-54- | P | W | N |
2 X 54W

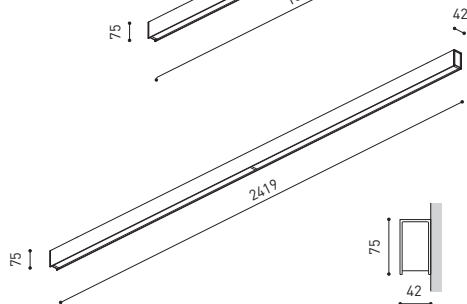

PROFILE 040 Wall

COLOUR | P ■ | W □ | N ■ |

MATERIAL | AL | PC |

» 452

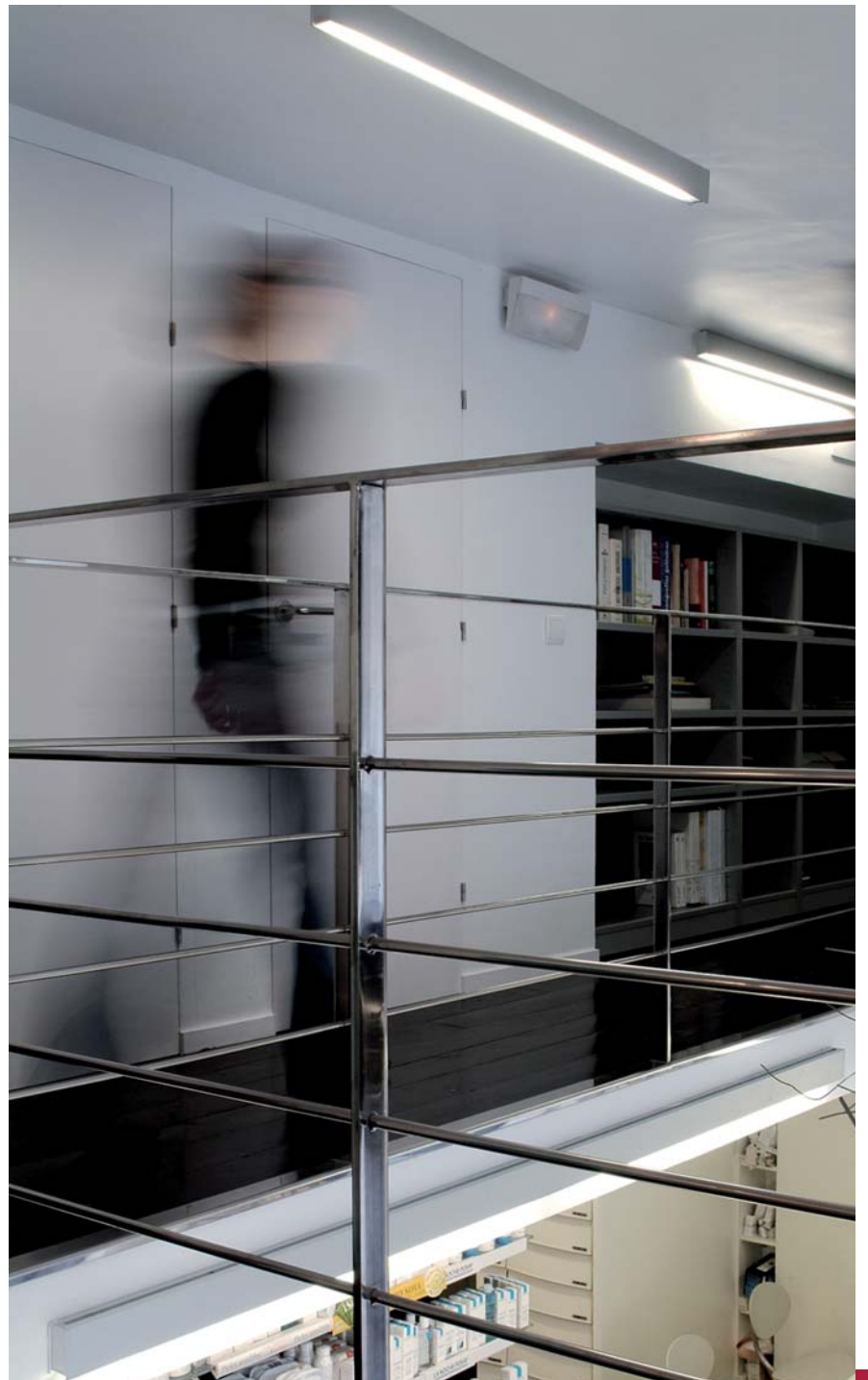



2594-05-39- | P | W | N |
 1 X 39W
 53 X 943

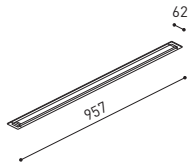

2594-05-39- | LP | LW | LN |
 1 X 39W
 53 X 943

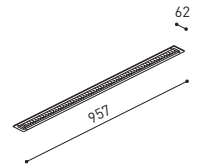

2594-05-54- | P | W | N |
 1 X 54W
 53 X 1243

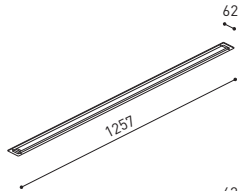

2594-05-54- | LP | LW | LN |
 1 X 54W
 53 X 1243

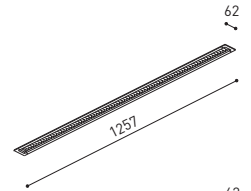

2594-05-80- | P | W | N |
 1 X 80W
 53 X 1543

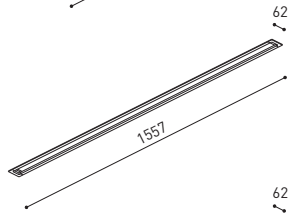

2594-05-80- | LP | LW | LN |
 1 X 80W
 53 X 1543

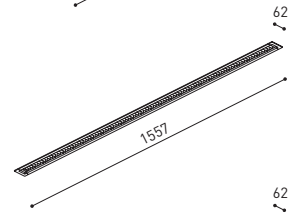

2594-07-39- | P | W | N |
 2 X 39W
 53 X 1843

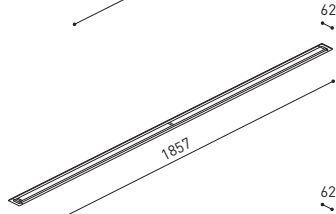

2594-07-39- | LP | LW | LN |
 2 X 39W
 53 X 1843

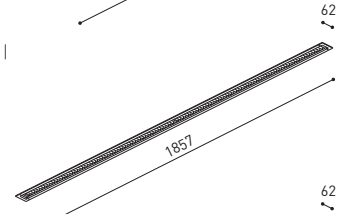

2594-07-54- | P | W | N |
 2 X 54W
 53 X 2443

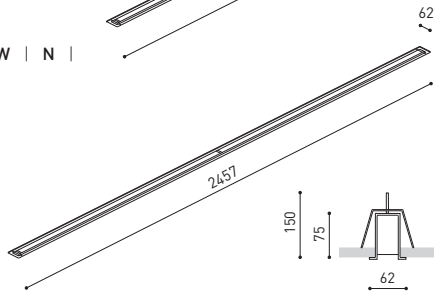

2594-07-54- | LP | LW | LN |
 2 X 54W
 53 X 2443

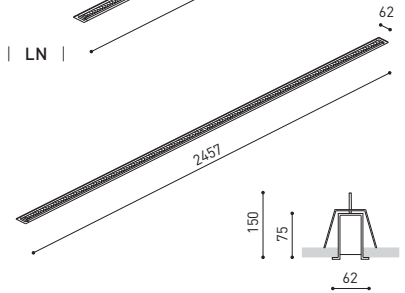

PROFILE 040 Recessed



COLOUR | P ■ | W □ | N ■ | MATERIAL | AL | PC |

PROFILE 040 Recessed Louver



COLOUR | LP ■ | LW □ | LN ■ | MATERIAL | AL | » 394



PROFILE 040 CUSTOM

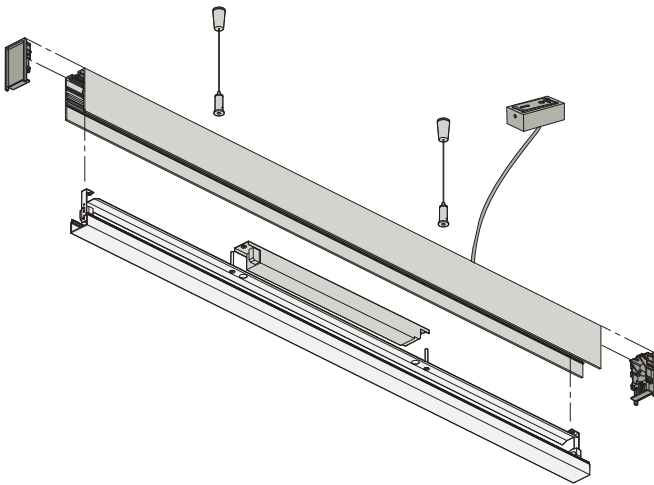

See VIRTUAL PROFILE software at www.arkoslight.com

PROFILE 040 CUSTOM Surface and Suspension Chassis

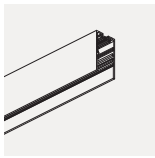

2594-99-10-	P W N	L: 911 mm
2594-99-11-	P W N	L: 1211 mm
2594-99-12-	P W N	L: 1511 mm
2594-99-13-	P W N	L: 1811 mm
2594-99-14-	P W N	L: 2411 mm

Wall chassis, please consult



PROFILE 040 CUSTOM Recessed Chassis

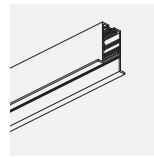

2594-99-20-	P W N	L: 911 mm
2594-99-21-	P W N	L: 1211 mm
2594-99-22-	P W N	L: 1511 mm
2594-99-23-	P W N	L: 1811 mm
2594-99-26-	P W N	L: 2411 mm

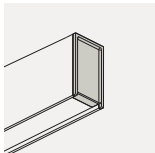
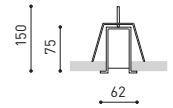

PROFILE 040 Surface End Cap		
2594-99-30-	Q	L: 4 mm

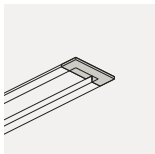

PROFILE 040 Recessed end Cap		
2594-99-31-	Q W N	L: 23 mm

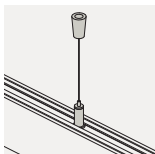

PROFILE 040 Suspension Cable		
2594-99-37-	Q	

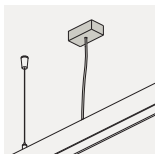

PROFILE 040 Suspension Feeder Cable		
2594-99-70		L: 2,5 m
2594-99-40	Push	L: 2,5 m

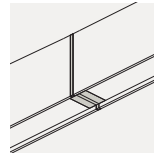

PROFILE 040 Surface 180° Joint for Two Chassis		
2594-99-33-	Q	L: 3 mm

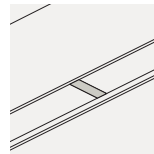

PROFILE 040 Surface and Recessed Separator-Button		
2594-99-32-	Q W N	L: 10 mm

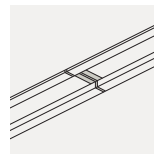

PROFILE 040 Recessed 180° Joint		
2594-99-34-	Q W N	L: 3 mm

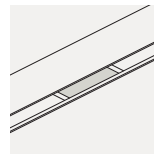

PROFILE 040 Separator Modules		
2594-99-15-	P W N	L: 140 mm
2594-99-16-	P W N	L: 290 mm
2594-99-17-	P W N	L: 440 mm
2594-99-18-	P W N	L: 590 mm

COLOUR | P ■ | W □ | N ■ | Q ■ | PQ ■ | WQ □ | NQ ■ |

PROFILE 040 MODULES FOR LAMPS

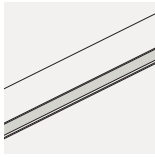

AL + PC

POLYCARBONATE	L	W			LOUVER
2594-99-24	590 mm	1 X 24W	INCL ELEC		
2594-97-24	590 mm	1 X 24W	INCL ELEC		
2594-99-56	590 mm		EXCL		
2594-97-56	590 mm		EXCL		
2594-99-55	590 mm	2 X 24W	INCL ELEC		
2594-97-55	590 mm	2 X 24W	INCL ELEC		
2594-99-39	890 mm	1 X 39W	INCL ELEC		2594-99-39- L
2594-97-39	890 mm	1 X 39W	INCL ELEC		2594-97-39- L
2594-99-58	890 mm		EXCL		2594-99-58- L
2594-97-58	890 mm		EXCL		2594-97-58- L
2594-99-57	890 mm	2 X 39W	INCL ELEC		2594-99-57- L
2594-97-57	890 mm	2 X 39W	INCL ELEC		2594-97-57- L
2594-99-54	1190 mm	1 X 54W	INCL ELEC		2594-99-54- L
2594-97-54	1190 mm	1 X 54W	INCL ELEC		2594-97-54- L
2594-99-60	1190 mm		EXCL		2594-99-60- L
2594-97-60	1190 mm		EXCL		2594-97-60- L
2594-99-59	1190 mm	2 X 54W	INCL ELEC		2594-99-59- L
2594-97-59	1190 mm	2 X 54W	INCL ELEC		2594-97-59- L
2594-99-80	1490 mm	1 X 80W	INCL ELEC		2594-99-80- L
2594-97-80	1490 mm	1 X 80W	INCL ELEC		2594-97-80- L

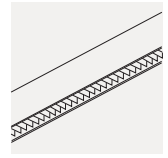

AL



T5



G5



220V
240V 50/60 Hz



IP20



PUSH | DSI

For dimmable options or "high efficiency" powers, please consult

PROFILE 040 CUSTOM

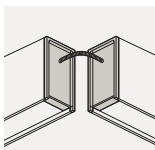

PROFILE 040 Universal Joint

2594-99-45- | Q |
2594-99-46- | Q | Push

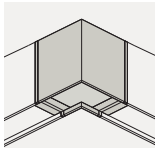

PROFILE 040 Surface 90° Corner

2594-99-35- | PQ | WQ | NQ | L: 78 X 78 mm

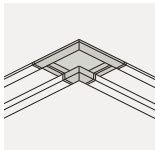

PROFILE 040 Recessed 90° Corner

2594-99-36- | PQ | W | N | L: 88 X 88 mm

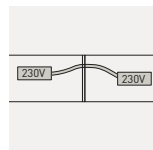

PROFILE 040 Electrical Connection

2594-99-47
2594-99-48 Push

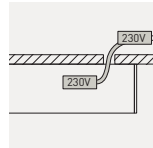

PROFILE 040 Surface Feeder Cable

2594-99-72
2594-99-42 Push

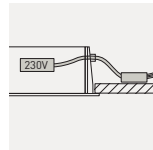

PROFILE 040 Recessed Feeder Cable

2594-99-74
2594-99-44 Push



MATERIAL | AL | » 452

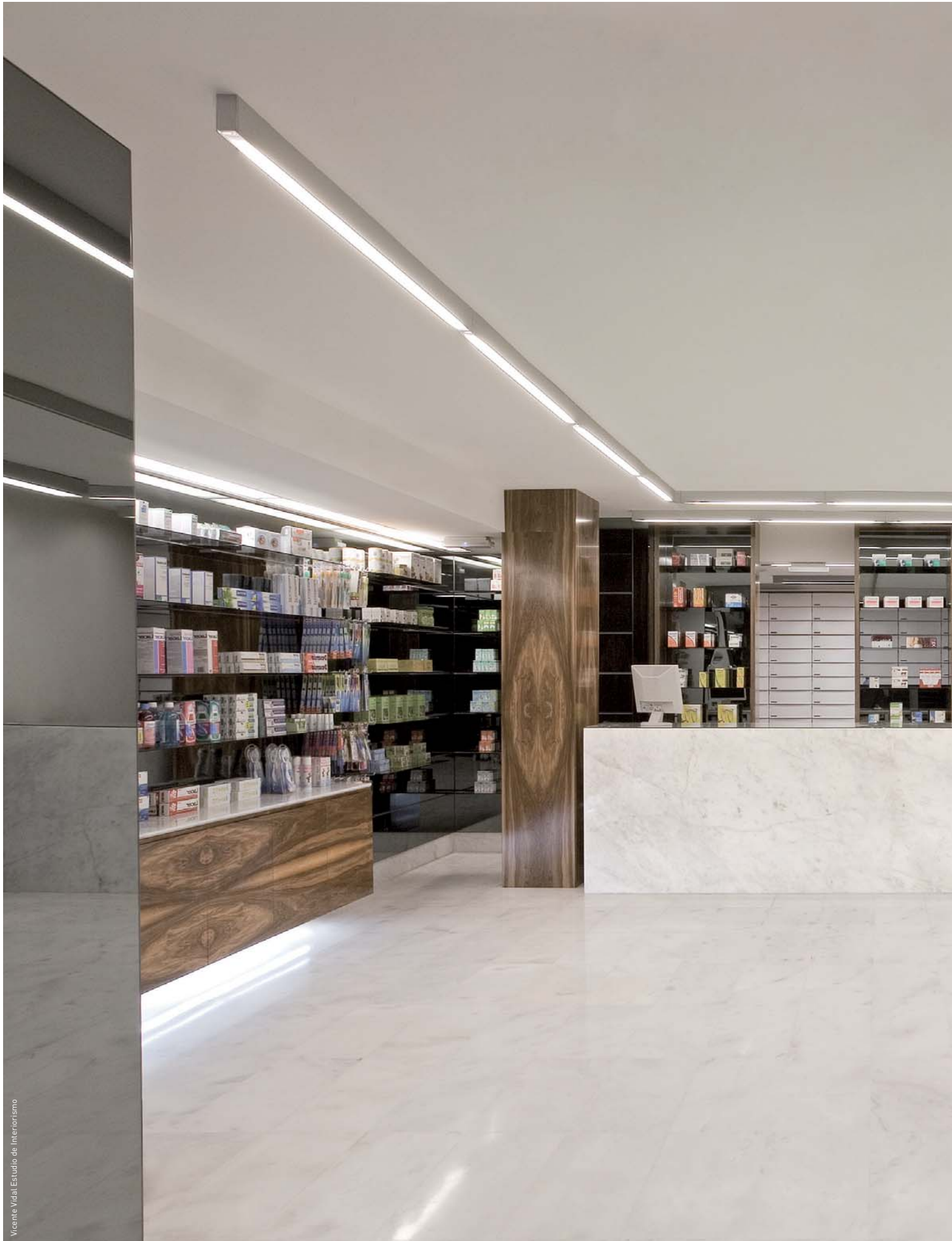



PROFILE 140



| P |

| W |

| N |

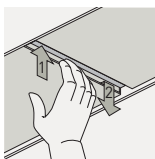

Easy diffuser removal



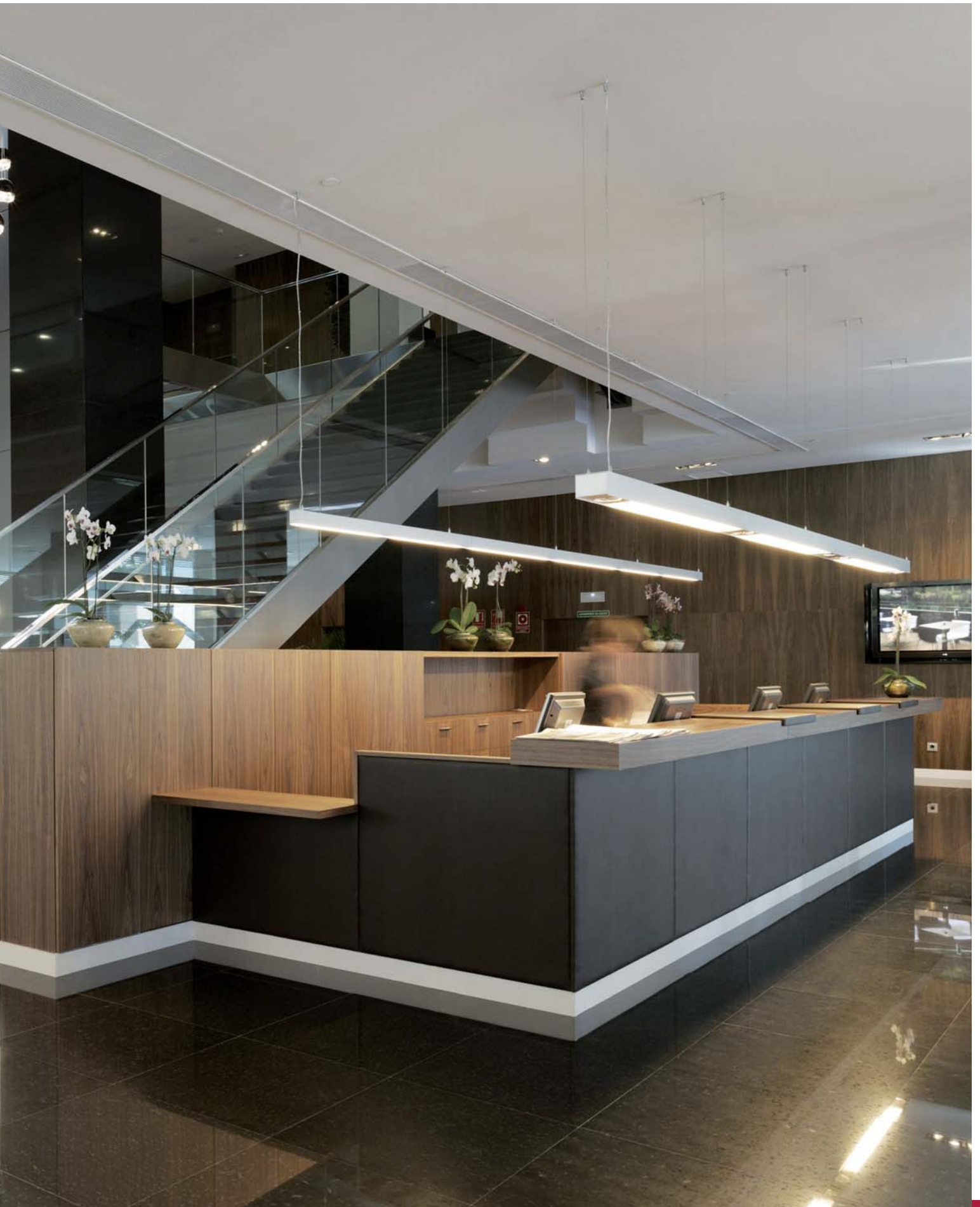



2594-50-39- | P | W | N |
2 X 39W

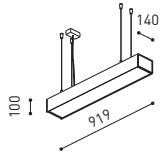

2594-50-54- | P | W | N |
2 X 54W

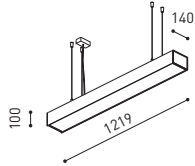

2594-50-80- | P | W | N |
2 X 80W

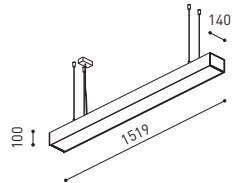

2594-42-39- | P | W | N |
4 X 39W

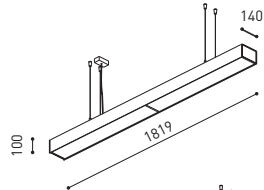

2594-52-54- | P | W | N |
4 X 54W

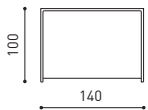
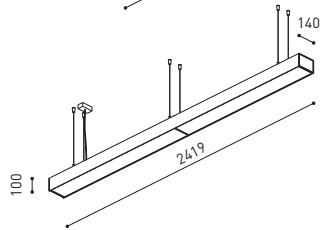

PROFILE 140 Susp



COLOUR | P ■ | W □ | N ■ | MATERIAL | AL | PC |



2594-50-39- | LP | LW | LN |
2 X 39W

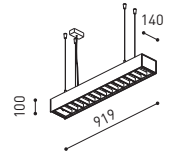

2594-50-54- | LP | LW | LN |
2 X 54W

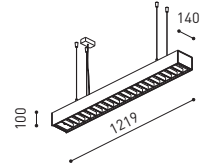

2594-50-80- | LP | LW | LN |
2 X 80W

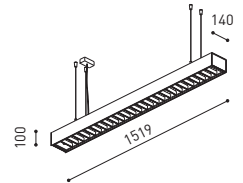

2594-42-39- | LP | LW | LN |
4 X 39W

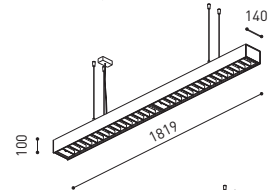

2594-52-54- | LP | LW | LN |
4 X 54W

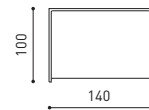
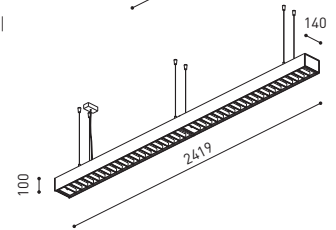

PROFILE 140 Susp Louvre



COLOUR | LP ■ | LW □ | LN ■ | MATERIAL | AL | » 452











2594-43-39- | P | W | N |
2 X 39W

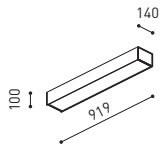

2594-43-39- | LP | LW | LN |
2 X 39W

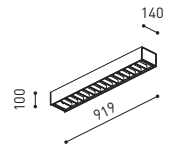

2594-43-54- | P | W | N |
2 X 54W

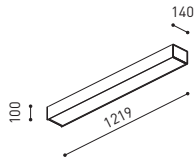

2594-43-54- | LP | LW | LN |
2 X 54W

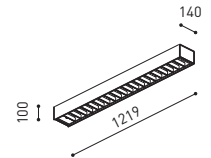

2594-43-80- | P | W | N |
2 X 80W

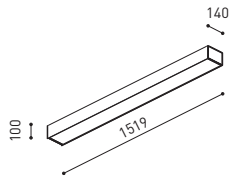

2594-43-80- | LP | LW | LN |
2 X 80W

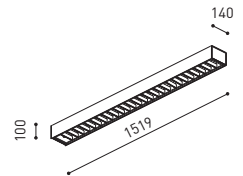

2594-44-39- | P | W | N |
4 X 39W

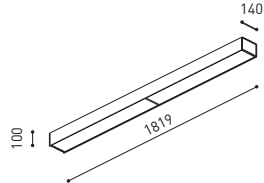

2594-44-39- | LP | LW | LN |
4 X 39W

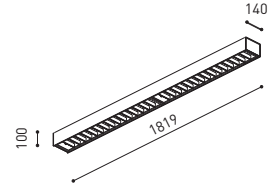

2594-44-54- | P | W | N |
4 X 54W

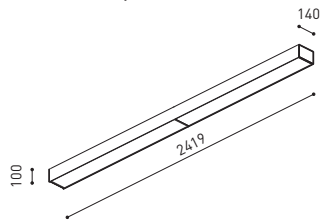

2594-44-54- | LP | LW | LN |
4 X 54W

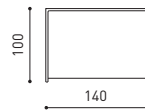
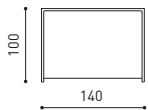
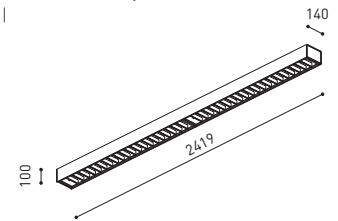

PROFILE 140 Surface



PROFILE 140 Surface Louver



COLOUR | P ■ | W □ | N ■ | MATERIAL | AL | PC |

COLOUR | LP ■ | LW □ | LN ■ | MATERIAL | AL | » 452









2594-55-39- | P | W | N |
 2 X 39W
 150 X 943

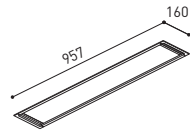

2594-55-39- | LP | LW | LN |
 2 X 39W
 150 X 943

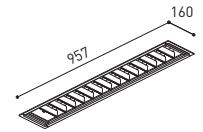

2594-55-54- | P | W | N |
 2 X 54W
 150 X 1243

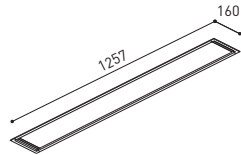

2594-55-54- | LP | LW | LN |
 2 X 54W
 150 X 1243

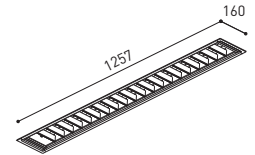

2594-55-80- | P | W | N |
 2 X 80W
 150 X 1543

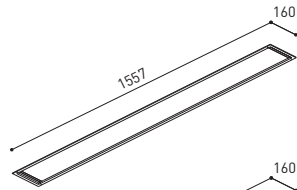

2594-55-80- | LP | LW | LN |
 2 X 80W
 150 X 1543

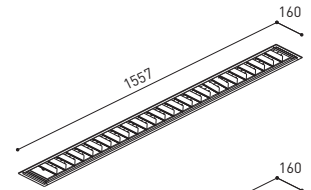

2594-47-39- | P | W | N |
 4 X 39W
 150 X 1843

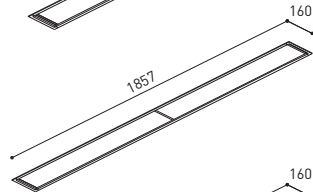

2594-47-39- | LP | LW | LN |
 4 X 39W
 150 X 1843

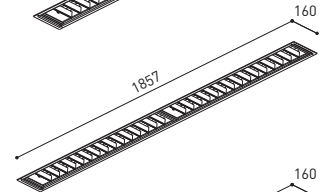

2594-57-54- | P | W | N |
 4 X 54W
 150 X 2443

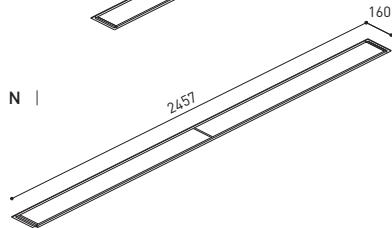

2594-57-54- | LP | LW | LN |
 4 X 54W
 150 X 2443

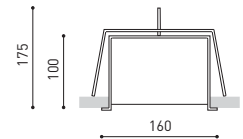
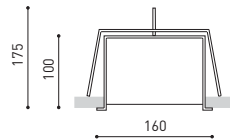
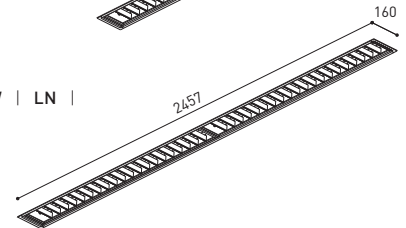

PROFILE 140 Recessed



PROFILE 140 Recessed Louver



COLOUR | P ■ | W □ | N ■ | MATERIAL | AL | PC |

COLOUR | LP ■ | LW □ | LN ■ | MATERIAL | AL | » 452





Photography: Joao Morgado – Fotografia de Arquitectura - www.photo.joaomorgado.com



2594-55-39- | AP | AW | AN |

1 X 39W

 150 X 943

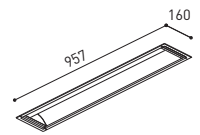

2594-55-54- | AP | AW | AN |

1 X 54W

 150 X 1243

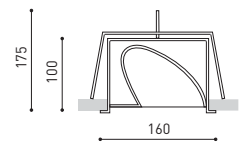
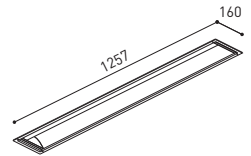

PROFILE 140 Recessed Wall-Washer



COLOUR | AP  | AW  | AN  |

MATERIAL |  AL |

PROFILE 140 CUSTOM

See VIRTUAL PROFILE software at www.arkoslight.com

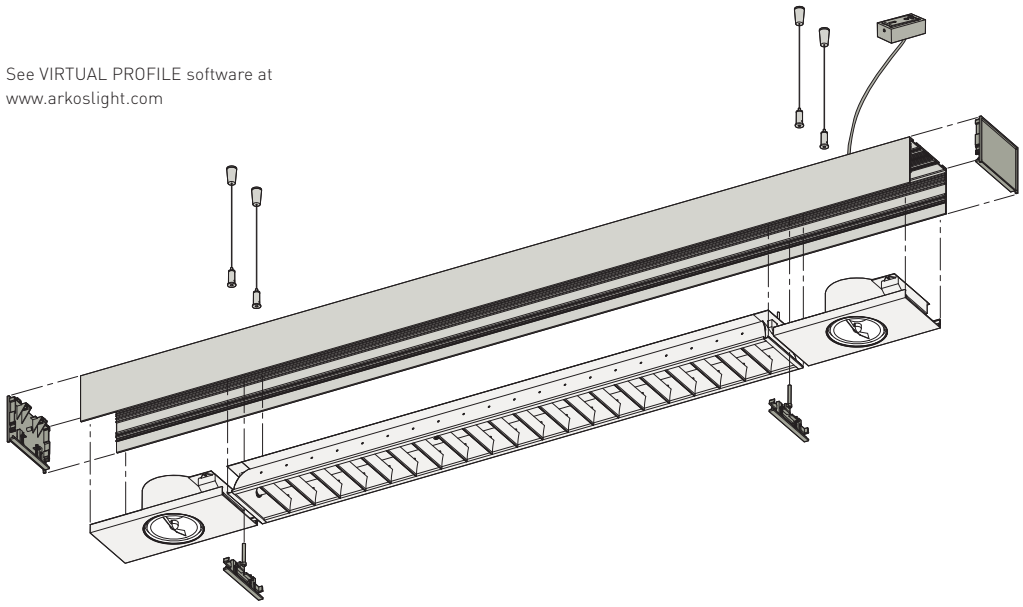

PROFILE 140 CUSTOM Surface and Suspension Chassis

	2594-98-10- P W N	L: 911 mm
	2594-98-11- P W N	L: 1211 mm
	2594-98-12- P W N	L: 1511 mm
	2594-98-13- P W N	L: 1811 mm
	2594-98-14- P W N	L: 2411 mm

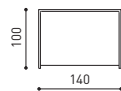

PROFILE 140 CUSTOM Recessed Chassis

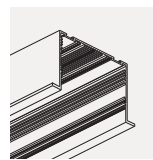
	2594-98-20- P W N	L: 911 mm
	2594-98-21- P W N	L: 1211 mm
	2594-98-22- P W N	L: 1511 mm
	2594-98-23- P W N	L: 1811 mm
	2594-98-26- P W N	L: 2411 mm

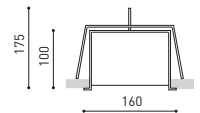

PROFILE 140 CUSTOM

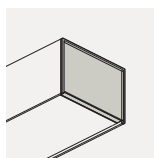
	PROFILE 140 Surface End Cap 2594-98-30- Q	L: 4 mm
---	---	---------

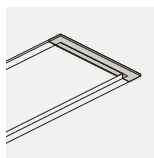
	PROFILE 140 Recessed End Cap 2594-98-31- Q W N	L: 23 mm
---	--	----------

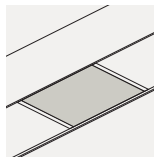
	PROFILE 140 Separator Modules 2594-98-15- P W N 2594-98-16- P W N 2594-98-17- P W N 2594-98-18- P W N 2594-98-19- P W N	L: 140 mm L: 290 mm L: 440 mm L: 590 mm L: 740 mm
---	---	---

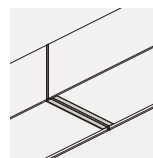
	PROFILE 140 Surface 180° Joint for Two Chassis 2594-98-33- Q	L: 3 mm
---	--	---------

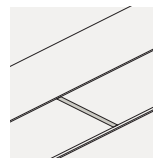
	PROFILE 140 Surface and Recessed Separator-Button 2594-98-32- Q W N	L: 10 mm
---	---	----------

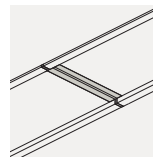
	PROFILE 140 Recessed 180° Joint 2594-98-34- Q W N	L: 3 mm
---	---	---------

COLOUR | P ■ | W □ | N ■ | Q ■ | PQ ■ | PW □ | PN ■ |

PROFILE 140 MODULES FOR LAMPS

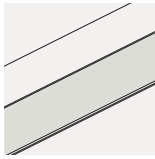

AL + PC

POLYCARBONATE	L	W		LOUVER
2594-98-24	590 mm	2 X 24W		2594-98-24- L
2594-96-24	590 mm	2 X 24W		2594-96-24- L
2594-98-39	890 mm	2 X 39W		2594-98-39- L
2594-96-39	890 mm	2 X 39W		2594-96-39- L
2594-98-54	1190 mm	2 X 54W		2594-98-54- L
2594-96-54	1190 mm	2 X 54W		2594-96-54- L
2594-98-80	1490 mm	2 X 80W		2594-98-80- L
2594-96-80	1490 mm	2 X 80W		2594-96-80- L

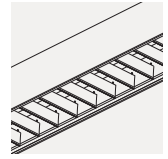

AL

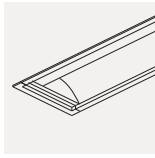

AL

WALL-WASHER	L	W		WALL-WASHER	L	W
2594-98-39- A	890 mm	1 X 39W		2594-98-54- A	1190 mm	1 X 54W
2594-96-39- A	890 mm	1 X 39W		2594-96-54- A	1190 mm	1 X 54W
2594-98-42- A	890 mm	2 X 39W		2594-98-56- A	1190 mm	2 X 54W
2594-96-42- A	890 mm	2 X 39W		2594-96-56- A	1190 mm	2 X 54W
2594-98-43- A	890 mm	Without Ballast		2594-98-57- A	1190 mm	Without Ballast
2594-96-43- A	890 mm	Without Ballast		2594-96-57- A	1190 mm	Without Ballast



PROFILE 140 CUSTOM

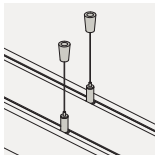

PROFILE 140 Suspension Cable

2594-99-37- | Q |



For Profile 140 order in pairs

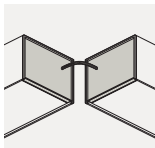

PROFILE 140 Universal Joint

2594-98-37- | Q |

2594-98-38- | Q |

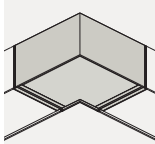

PROFILE 140 Surface 90° Corner

2594-98-35- | PQ | PW | PN | L: 203 X 203 mm

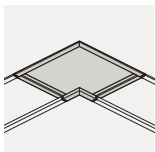

PROFILE 140 Recessed 90° Corner

2594-98-36- | PQ | W | N | L: 213 X 213 mm

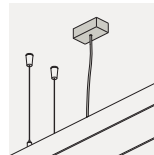

PROFILE 140 Suspension Feeder Cable

2594-99-70 Only - T5

2594-99-38 L: 2,5 m

2594-99-40 Push L: 2,5 m

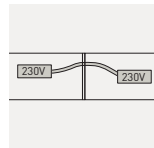

PROFILE 140 Electrical Connection

2594-99-47

2594-99-48 Push

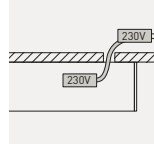

PROFILE 140 Surface Feeder Cable

2594-99-72 Only - T5

2594-99-41

2594-99-42 Push

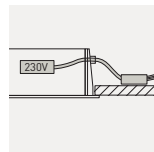

PROFILE 140 Recessed Feeder Cable

2594-99-74 Only - T5

2594-99-43

2594-99-44 Push



MATERIAL | AL |

» 452



PROFILE 140 CUSTOMIZABLE

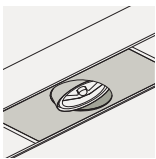

PROFILE 140 MODULES FOR QR-111 LAMPS

2594-98-03- | P | W | N |

L: 290 mm MAX 1 X 50W

2594-98-04- | P | W | N |

L: 590 mm MAX 2 X 50W



QR-111*



G53



0.5m



355°



30°



IP20



220V
240V

50/60 Hz



INCL ELEC

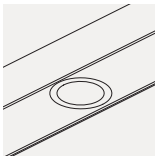

PROFILE 140 MODULES FOR METAL HALIDE

2594-98-05- | P | W | N | L: 1190 mm 70W

2594-98-06- | P | W | N | L: 1190 mm 150W

2594-98-07- | P | W | N | L: 1190 mm 70W

2594-98-08- | P | W | N | L: 1190 mm 150W



HIT-DE



RX7S



1m



HIT



G12



1m



IP20



220V
240V

50/60 Hz



INCL ELEC

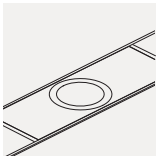

PROFILE 140 ONLY FOR RECESSED OPTION

2594-98-57- | P | W | N | L: 290 mm 70W

2594-98-58- | P | W | N | L: 290 mm 150W



HIT



G12



1m



IP20



220V
240V

50/60 Hz



INCL ELEC

PROFILE 220



Photography: Yann Delanaux, Photographie Professionnel - MINI Store, Toulouse





2601-00-39- | Z | W |
2 X 39W

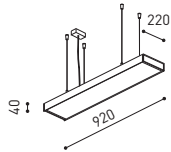

2601-20-39- | Z | W |
2 X 39W

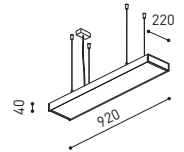

2601-00-54- | Z | W |
2 X 54W

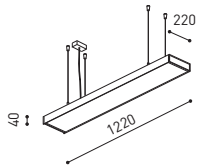

2601-20-54- | Z | W |
2 X 54W

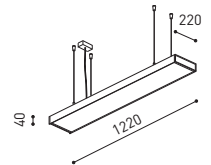

2601-00-80- | Z | W |
2 X 80W

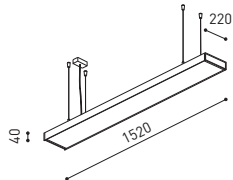

2601-20-80- | Z | W |
2 X 80W

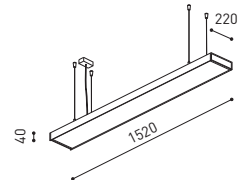

PROFILE 220 Susp Down



PROFILE 220 Susp Up & Down



COLOUR | Z ■ | W □ | MATERIAL | AL | PC | ⓘ » 452



Photography: James Silverman - www.jamesilverman.co.uk







Photography: Yann Delanaux, Photographe Professionnel - MINI Store, Toulouse

Photography: Yann Delanaux, Photographie Professionnel - MINI Store, Toulouse

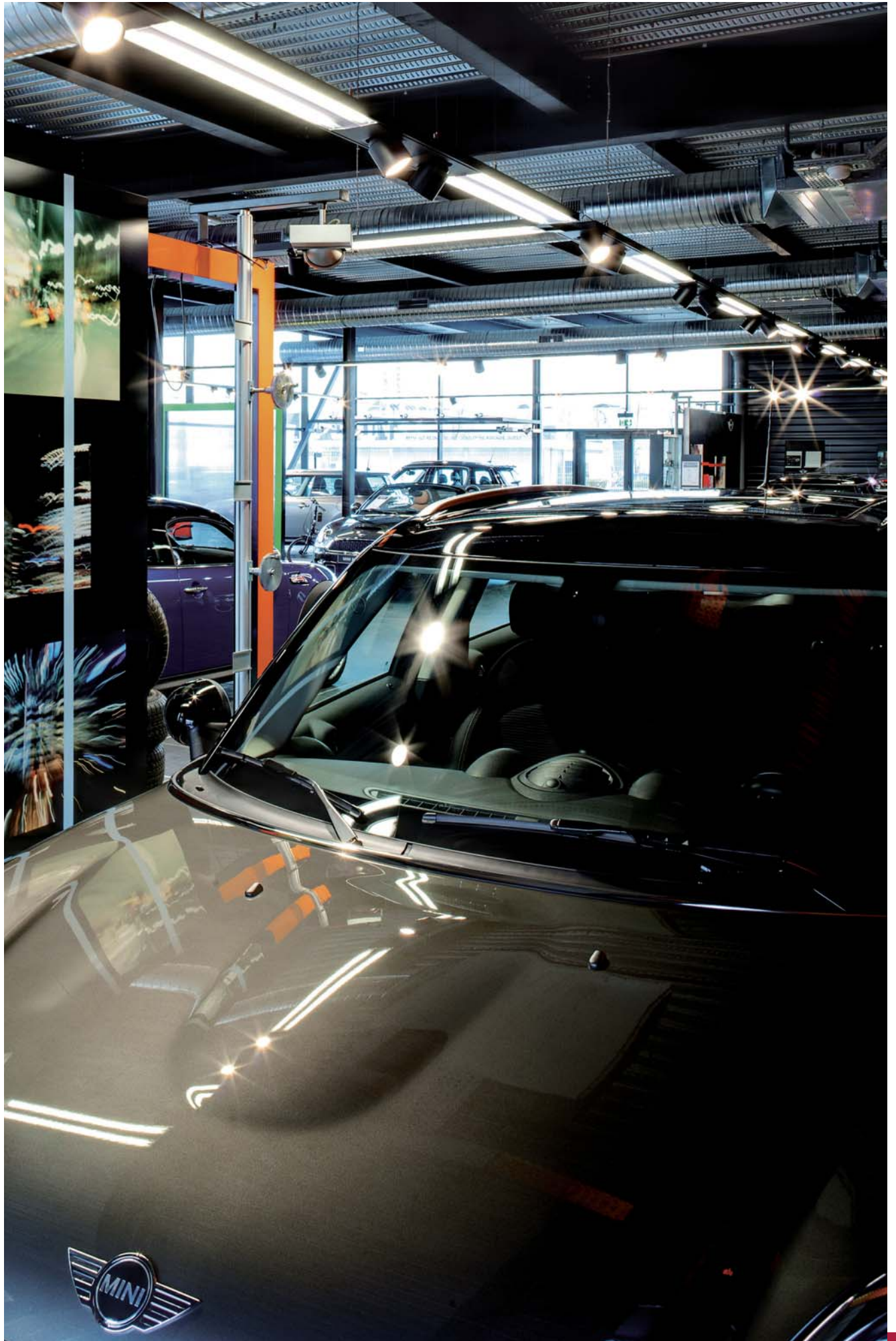



2601-05-39- | Z | W |
 2 X 39W
 2 X QR-111 MAX 50W

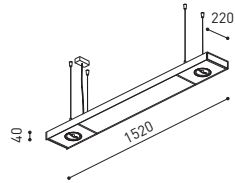

2601-05-54- | Z | W |
 2 X 54W
 2 X QR-111 MAX 50W

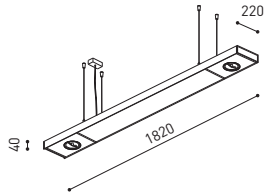

2601-25-39- | Z | W |
 2 X 39W
 2 X QR-111 MAX 50W

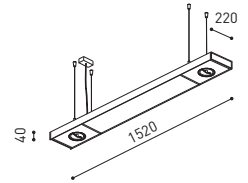

2601-25-54- | Z | W |
 2 X 54W
 2 X QR-111 MAX 50W

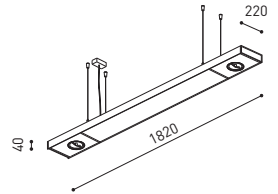

PROFILE 220 Susp Down + 2 QR-111

		50/60 Hz			2 m			
	LED LARK-111 12 V OPTIONS*							

PROFILE 220 Susp Up & Down + 2 QR-111

		50/60 Hz			2 m			
	LED LARK-111 12 V OPTIONS*							

COLOUR | Z ■ | W □ |

MATERIAL | AL | PC |

* LARK-111 | 12V OPTIONS » 453 | » 452







Photography: Yann Delanaux, Photographie Professionnel - MINI Store, Toulouse

surface & suspended









SKY 332



ORBITAL SURFACE 336



ZEN TUBE 344



KON SURFACE 348



MOVE SURFACE 352



SURF 358



ZOOM 360



SPIDER 376



BRIGIT SUSPENSION 394

NEW

SKY



		W	K	mA	Lm	%Eff
SKY 2	A195-02- Ⓞ -1- WT	20W	3000K	700	2200	78%
	A195-02- Ⓞ -2- WT	20W	4000K	700	2300	78%
SKY 3	A195-03- Ⓞ -1- WT	24W	3000K	700	2700	78%
	A195-03- Ⓞ -2- WT	24W	4000K	700	2800	78%
SKY 4	A195-04- Ⓞ -1- WT	36W	3000K	1050	4050	78%
	A195-04- Ⓞ -2- WT	36W	4000K	1050	4150	78%
SKY 5	A195-05- Ⓞ -1- WT	46W	3000K	1200	5050	78%
	A195-05- Ⓞ -2- WT	46W	4000K	1200	5150	78%

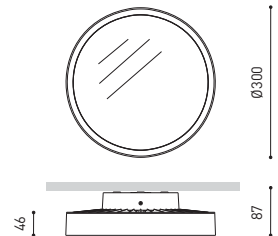

50/60 Hz

Ⓞ OPTIONS*

1	No DIM
2	DIM Push
3	DIM 1-10V
4	DIM DALI

COLOUR | WT | MATERIAL | AL | PMMA | » 452 | » 468





Photography: Jesús Granada - Fotógrafo - www.jesusgranada.com



ORBITAL SURFACE

NEW



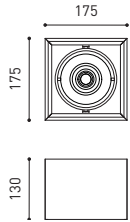

		W	BEAM	K	mA	Lm	%Eff
ORBITAL SURFACE 1 Lark-111	A011-11-11- Z W N	10,5W	24°	3000K	500	1070	94%
	A011-11-21- Z W N	10,5W	50°	3000K	500	1070	92%
	A011-12-11- Z W N	15W	24°	3000K	700	1440	94%
	A011-12-21- Z W N	15W	50°	3000K	700	1440	92%
	A011-13-11- Z W N	15W	24°	3000K	700	1440	94%
	A011-13-21- Z W N	15W	50°	3000K	700	1440	92%

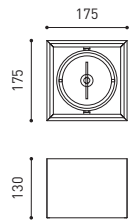

		W
ORBITAL SURFACE 1 QR-111	A010-01-05- Z W N	MAX 1 X 75W



ORBITAL SURFACE 1 CDM-R111	A010-01-06- Z W N	MAX 1 X 35W
	A010-01-07- Z W N	MAX 1 X 70W

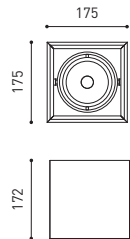

COLOUR | Z ■ | W □ | N ■ |

MATERIAL | AL | » 452

* LARK-111 | 12V & ** LARK 111 OPTIONS » 453 | » 468

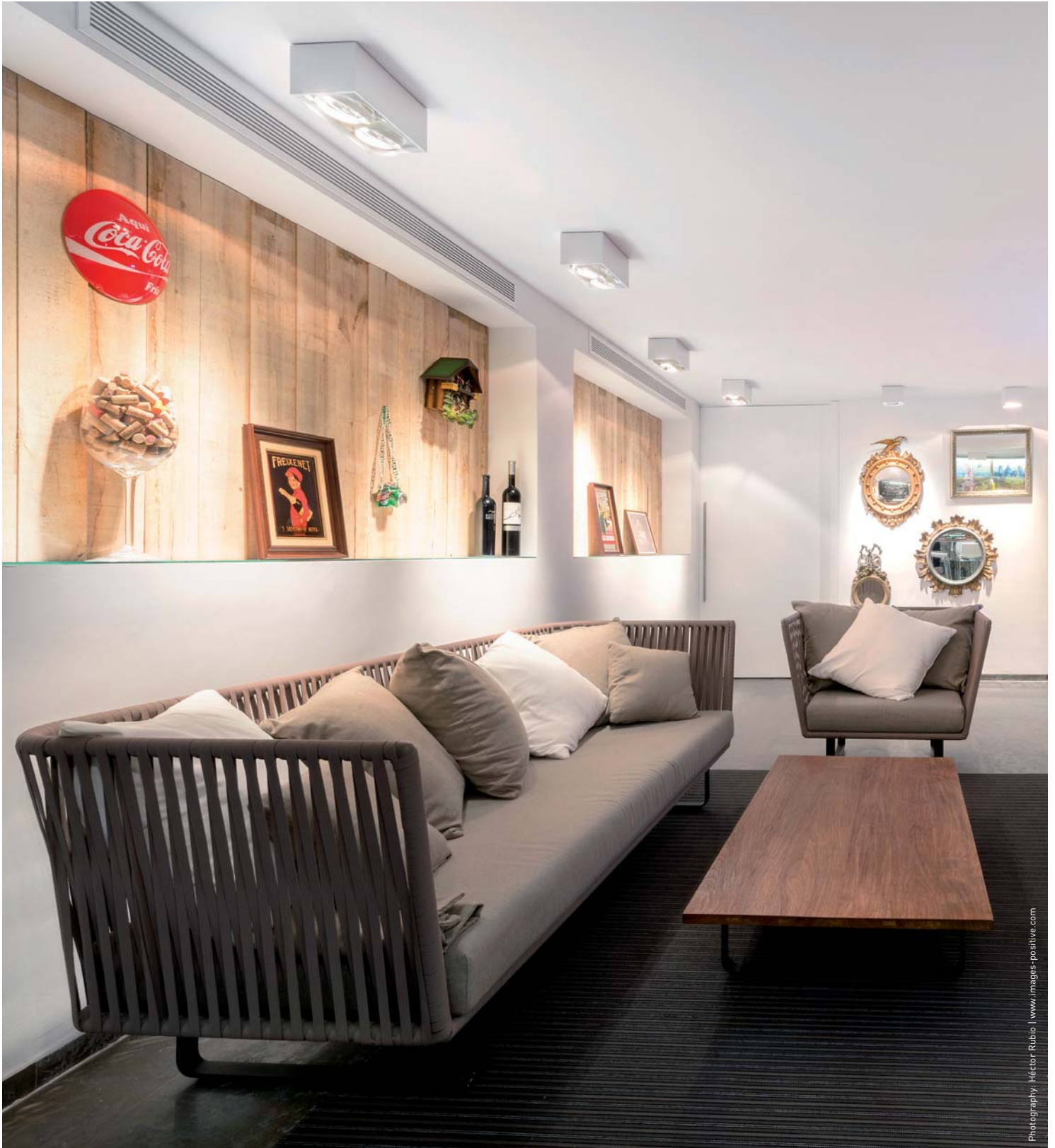

Photography: Héctor Rubio | www.images-positive.com

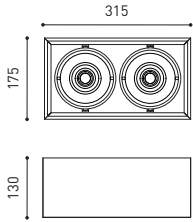

	W	BEAM	K	mA	Lm	%Eff	
ORBITAL SURFACE 2 Lark-111	A011-21-11- Z W N	2 X 10,5W	24°	3000K	500	2 X 1070	94%
	A011-21-21- Z W N	2 X 10,5W	50°	3000K	500	2 X 1070	92%
	A011-22-11- Z W N	2 X 15W	24°	3000K	700	2 X 1440	94%
	A011-22-21- Z W N	2 X 15W	50°	3000K	700	2 X 1440	92%
	A011-23-11- Z W N	2 X 15W	24°	3000K	700	2 X 1440	94%
	A011-23-21- Z W N	2 X 15W	50°	3000K	700	2 X 1440	92%

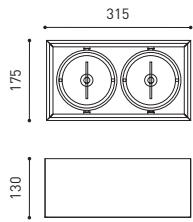

	W
ORBITAL SURFACE 2 QR-111	A010-02-05- Z W N
	MAX 2 X 75W



ORBITAL SURFACE 2 CDM-R111	A010-02-06- Z W N	MAX 2 X 35W
	A010-02-07- Z W N	MAX 2 X 70W

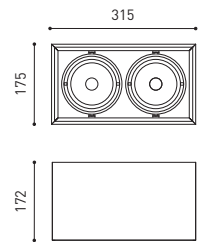
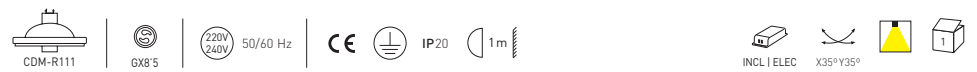

COLOUR | Z ■ | W □ | N ■ |

MATERIAL | AL | » 452

* LARK-111 | 12V & ** LARK 111 OPTIONS » 453 | » 468





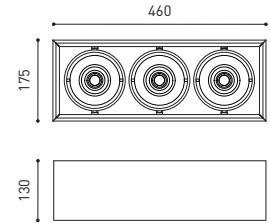

	W	BEAM	K	mA	Lm	%Eff	
ORBITAL SURFACE 3 Lark-111	A011-31-11- Z W N	3 X 10,5W	24°	3000K	500	3 X 1070	94%
	A011-31-21- Z W N	3 X 10,5W	50°	3000K	500	3 X 1070	92%
	A011-32-11- Z W N	3 X 15W	24°	3000K	700	3 X 1440	94%
	A011-32-21- Z W N	3 X 15W	50°	3000K	700	3 X 1440	92%
	A011-33-11- Z W N	3 X 15W	24°	3000K	700	3 X 1440	94%
	A011-33-21- Z W N	3 X 15W	50°	3000K	700	3 X 1440	92%

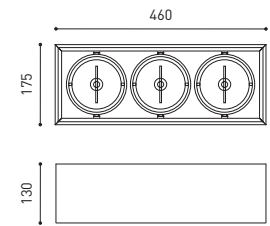

	W
ORBITAL SURFACE 3 QR-111	A010-03-07- Z W N MAX 3 X 75W



ORBITAL SURFACE 3 Combi	A010-03-03- Z W N MAX 2 X 75W 1 X 35W
	A010-03-04- Z W N MAX 2 X 75W 1 X 70W

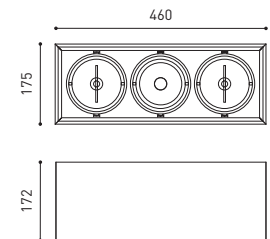
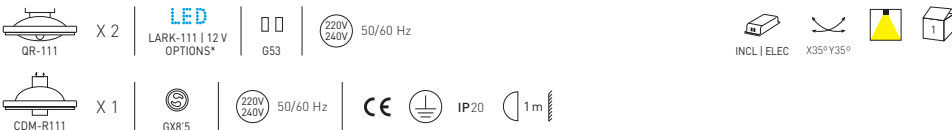

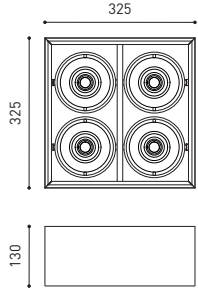

	W	BEAM	K	mA	Lm	%Eff
ORBITAL SURFACE 4 Lark-111						
A011-41-11- Z W N	4 X 10,5W	24°	3000K	500	4 X 1070	94%
A011-41-21- Z W N	4 X 10,5W	50°	3000K	500	4 X 1070	92%
A011-42-11- Z W N	4 X 15W	24°	3000K	700	4 X 1440	94%
A011-42-21- Z W N	4 X 15W	50°	3000K	700	4 X 1440	92%
▲▲▲ A011-43-11- Z W N	4 X 15W	24°	3000K	700	4 X 1440	94%
▲▲▲ A011-43-21- Z W N	4 X 15W	50°	3000K	700	4 X 1440	92%

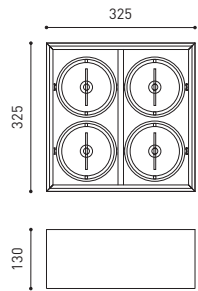

	W
ORBITAL SURFACE 4 QR-111	MAX 4 X 75W
A010-04-03- Z W N	

COLOUR | Z ■ | W □ | N ■ |

MATERIAL | AL | ⓘ » 452

* LARK-111 | 12V & ** LARK 111 OPTIONS » 453 ⓘ » 468

NEW

ZEN TUBE



		W	K	mA	Lm	%Eff
ZEN TUBE LED 1	A184-11- ☉ -1- WT NT	12W	3000K	350	1400	90%
	A184-11- ☉ -2- WT NT	12W	4000K	350	1500	90%
ZEN TUBE LED 2	A184-12- ☉ -1- WT NT	18W	3000K	500	1850	90%
	A184-12- ☉ -2- WT NT	18W	4000K	500	1950	90%
ZEN TUBE LED 3	A184-13- ☉ -1- WT NT	21,5W	3000K	640	2550	90%
	A184-13- ☉ -2- WT NT	21,5W	4000K	640	2650	90%

☉	BEAM OPTIONS
1	16°
2	24°
3	42°

	FOOD FILTER OPTIONS
	Bread 0700-07-01
	Meat 0700-07-02
	Fish 0700-07-03

	FILTER OPTIONS
	Red 0702-01-01
	Blue 0702-01-02
	Green 0702-01-03
	Orange 0702-01-04
	Yellow 0702-01-05

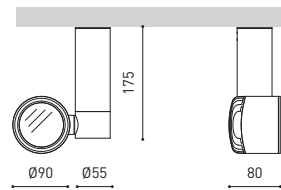

COLOUR | WT | NT |

MATERIAL | AL |

>> 452 | >> 468





Photography: James Silverman - www.jamesilverman.co.uk



NEW

KON SURFACE

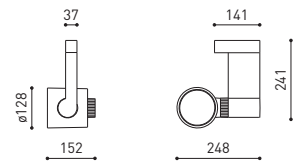

W

KON SURFACE **Lark-111**

REFERENCE PLEASE CONSULT

MAX 1 X 15W

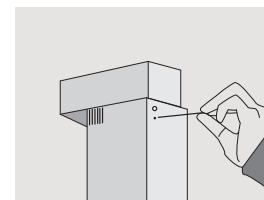

Individual internal potentiometer

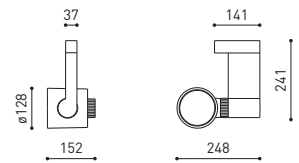

W

KON SURFACE **QR-111**

2534-00-00- | Z | W |

MAX 100W

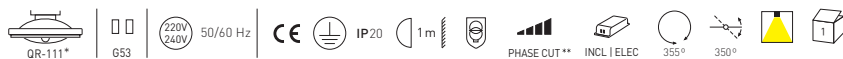

COLOUR | Z ■ | W □ |

MATERIAL | AL | i » 452

* LARK 111 OPTIONS » 453 | » 468

** ONLY TRAILING EDGE



		W
KON SURFACE CDM-R111	2539-00-35- Z W	35W
	2539-00-07- Z W	70W



		W
KON SURFACE PAR 30	2536-00-00- Z W	MAX 100W

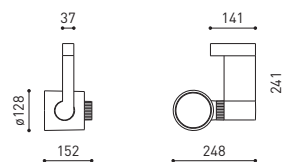



Photography: Paul Ott, Graz - Project: Gargoly & Kristiner Architekten

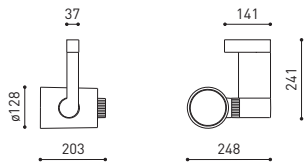

	BEAM	W
KON SURFACE G12	2538-01-07- Z W	56° 70W
	2538-01-15- Z W	56° 150W
	2538-02-07- Z W	33° 70W
	2538-02-15- Z W	33° 150W



FOOD FILTER OPTIONS

	Bread	0700-02-01
	Meat	0700-02-02
	Fish	0700-02-03

	W	
KON SURFACE P30 CDM-R	2537-00-35- Z W	35W
	2537-00-07- Z W	70W



COLOUR | Z ■ | W □ |

MATERIAL | AL |

» 452

MOVE SURFACE

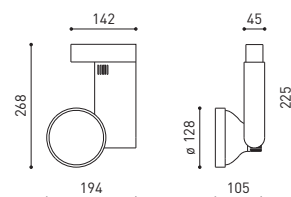

W

MOVE SURFACE QR-111 2502-01-10- | Z | W | MAX 100W

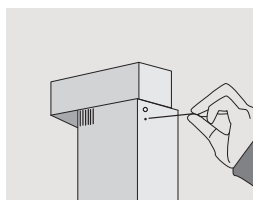
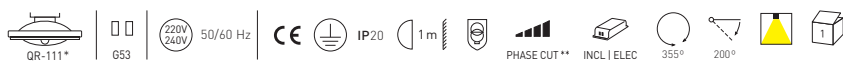

Individual internal potentiometer

W

MOVE SURFACE CDM-R111 2542-91-35- | Z | W | 35W

2542-91-07- | Z | W | 70W



COLOUR | Z ■ | W □ |

MATERIAL | AL |

* LARK 111 OPTIONS » 205 | » 220

** ONLY TRAILING EDGE | » 452

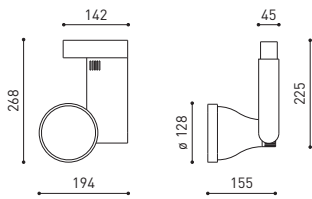

				BEAM	W
MOVE SURFACE G12	2582-01-35-	Z W	○ GL-MATT	89°	35W
	2582-01-07-	Z W	○ GL-MATT	89°	70W
	2582-01-15-	Z W	○ GL-MATT	89°	150W
	2582-02-35-	Z W	⊖ GL-TRANS	10°	35W
	2582-02-07-	Z W	⊖ GL-TRANS	10°	70W
	2582-02-15-	Z W	⊖ GL-TRANS	10°	150W



FOOD FILTER OPTIONS

●	Bread	0700-03-01
●	Meat	0700-03-02
●	Fish	0700-03-03

				W
MOVE SURFACE P30 CDM-R	2562-01-35-	Z W		35W
	2562-01-07-	Z W		70W



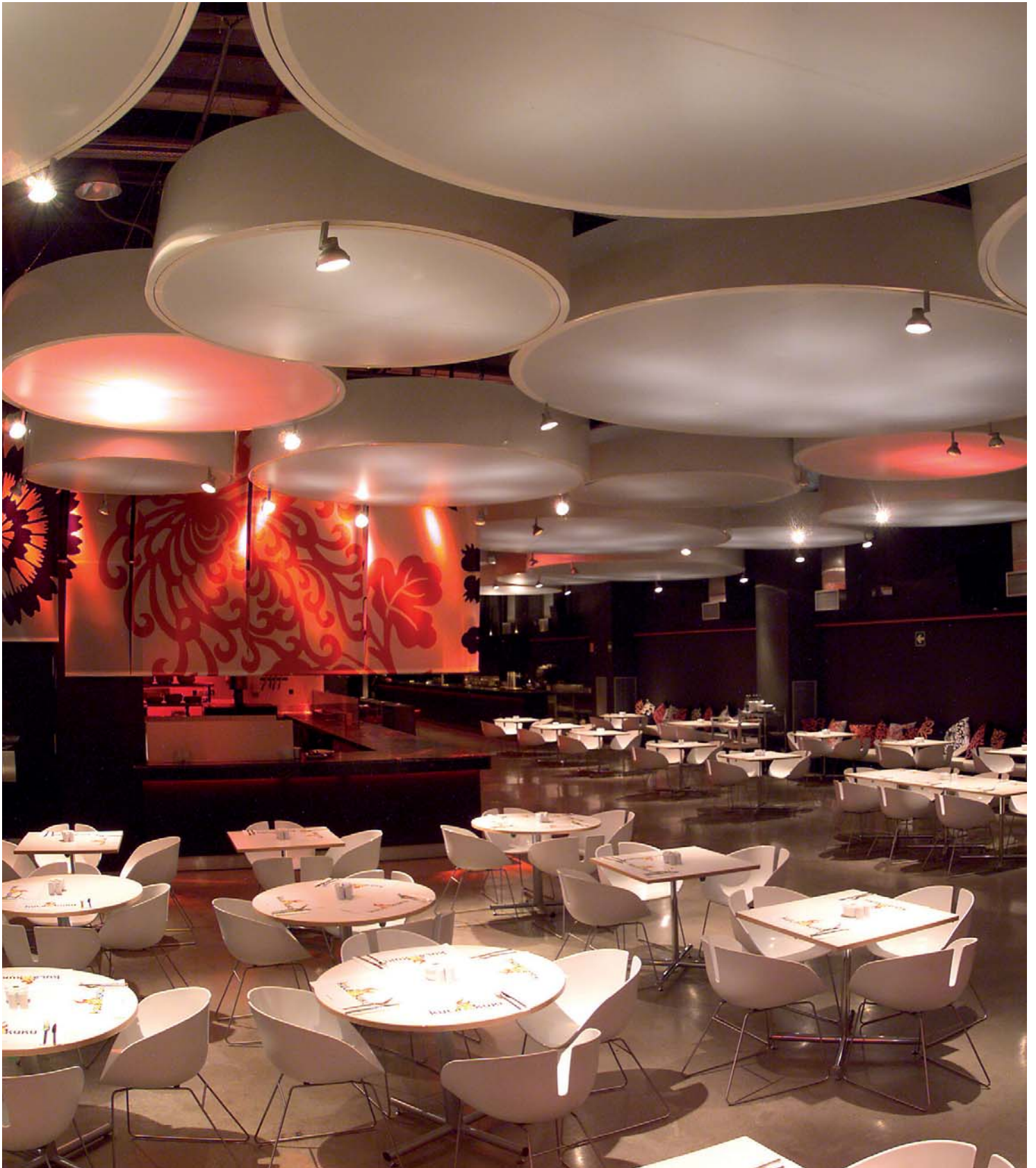

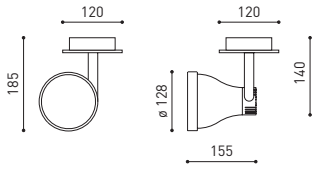

W

MOVE SURFACE PAR 30 2562-91-01- | Z | W | **MAX 100W**

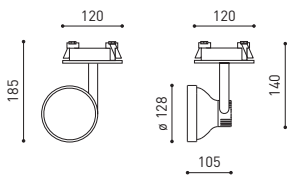

W

MOVE SURFACE QR-111 Recessed 2502-91-90- | Z | W | **MAX 100W**



W

MOVE SURFACE CDM-R111 Recessed 2542-91-00- | Z | W | **MAX 70W**



COLOUR | Z ■ | W □ |

MATERIAL | AL |

ⓘ >> 452



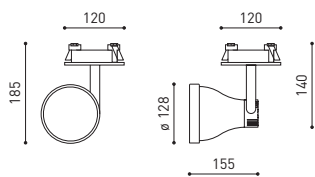

					BEAM	W
MOVE SURFACE G12 Recessed	2582-91-90-	Z W	GL-MATT	89°	MAX	150W
	2582-92-90-	Z W	GL-TRANS	10°	MAX	150W



FOOD FILTER OPTIONS

	Bread	0700-03-01
	Meat	0700-03-02
	Fish	0700-03-03

					W
MOVE SURFACE P30 CDM-R Recessed	2562-91-90-	Z W			MAX 70W



					W
MOVE SURFACE P30 Recessed	2562-91-91-	Z W			MAX 100W

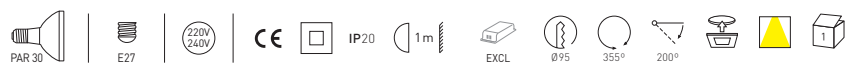

COLOUR | Z ■ | W □ |

MATERIAL | AL |

» 452

SURF



W

SURF 2 X 26W **4450-00-00-** | W | Z | 2 X 26W



○ GL-MATT

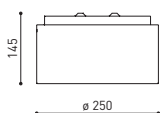

W

SURF 2 X 42W **4452-00-00-** | W | Z | 2 X 42W



○ NO GLASS

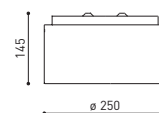

SURF Acc. Susp **0844-00-00-Q** L: 2 m

Electrical Kit included



COLOUR | W □ | Z ■ |

MATERIAL |  AL |

 » 452



ZOOM

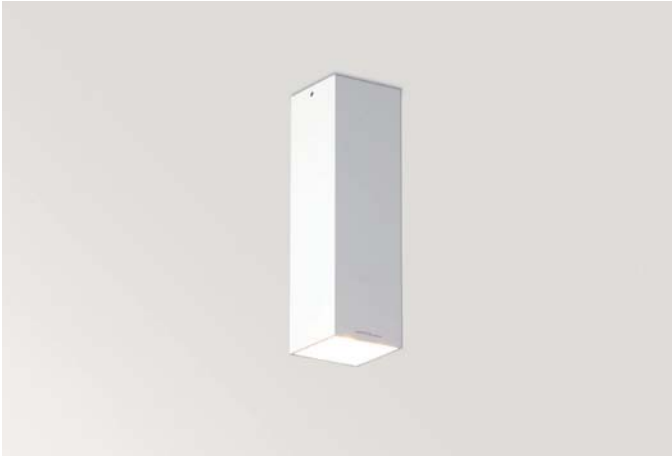

W

ZOOM 60 Surface Square 2506-60-00- | Z | W | MAX 50W



COLOUR | Z ■ | W □ |

MATERIAL |  AL |  » 452



Photography: Héctor Santos-Díez | Bisimages - www.bisimages.com



W

ZOOM 60 Surface Round 2504-60-00- | Z | W | **MAX 50W**

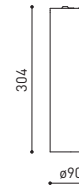

W

ZOOM 90 P25 Surface 2504-90-20- | Z | W | **MAX 75W**



W

ZOOM 90 Micro Surface 2504-90-10- | Z | W | **MAX 11W**





W

ZOOM 120 P30 Surface 2504-12-21- | Z | W | **MAX 100W**



W

ZOOM 120 QR-111 Surface 2504-12-30- | Z | W | **MAX 50W**

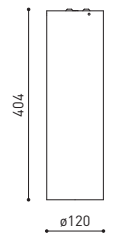

COLOUR | Z ■ | W □ |

MATERIAL | AL | » 452

* LARK-111 | 12V » 453 | » 468



Photography: Joao Morgado - Fotografia de Arquitectura - www.photo.joaoorgado.com





W

ZOOM 60 12V Susp 2505-60-40- | Z | W | MAX 50W



W

ZOOM 90 P25 Susp 2505-90-22- | Z | W | MAX 75W



W

ZOOM 60 GU 230V Susp 2505-60-01- | Z | W | MAX 50W

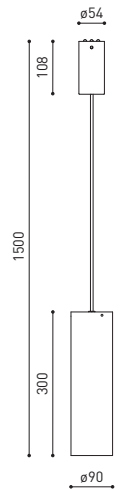
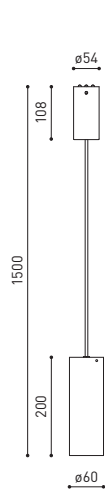

COLOUR | Z ■ | W □ |

MATERIAL | AL | ⓘ » 452

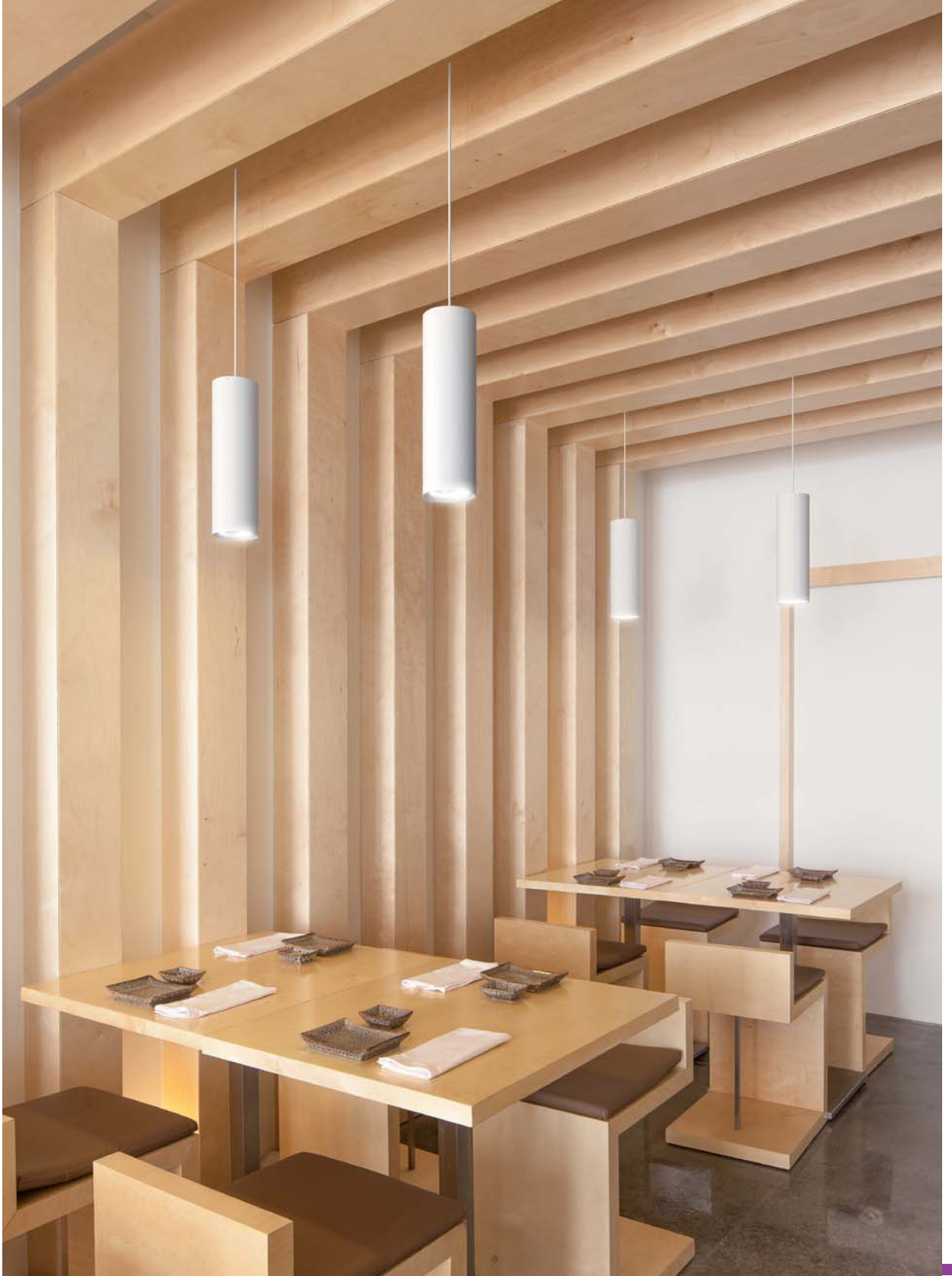



Photography: Héctor Santos - Diez - Bisimages - www.bisimages.com



Photography: Héctor Santos - Diez - Bismages - www.bismages.com



EBS Oficines, Lleida. Fotógrafo: Oriol Rosell. Proyecto: www.alfredgarciafotos.com



W

ZOOM 120 P30 Susp 2505-12-23- | Z | W | MAX 100W



W

ZOOM 120 QR-111 Susp 2505-12-31- | Z | W | MAX 50W

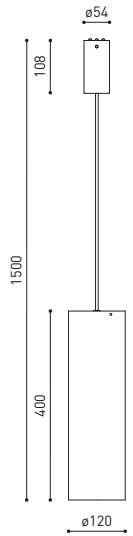

COLOUR | Z ■ | W □ |

MATERIAL | AL | ⓘ >> 452

* LARK-111 | 12V | ⓘ >> 453 | ⓘ >> 468





Photography: Jesús Granada | Bisimages - www.bisimages.com







SPIDER

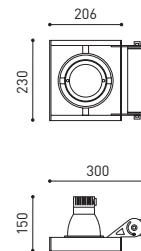

W

SPIDER 1P30 | 2563-11-00- | Z | **MAX 1 X 100W**

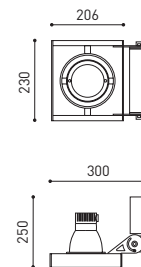

W

SPIDER P30 CDM-R | 2563-01-35- | Z | 35W
 2563-01-07- | Z | 70W



COLOUR | Z ■ | MATERIAL | AL | ⓘ » 452

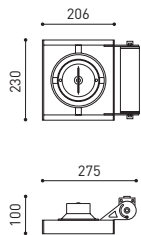

W

SPIDER 1 QR-111

2503-01-10- | Z |

MAX 1 X 100W

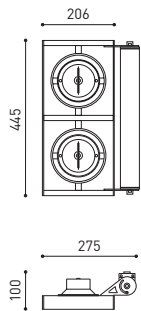

W

SPIDER 2 QR-111

2503-12-10- | Z |

MAX 2 X 100W



* LARK-111 | 12V  » 453 |  » 468

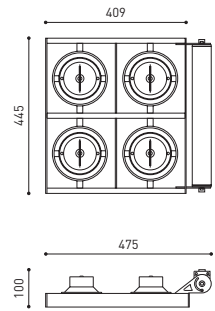

W

SPIDER 4 QR-111 2503-14-05- | Z | MAX 4 X 50W

LARK-111 | 12 V
 OPTIONS*

 50/60 Hz

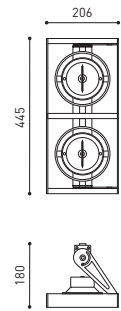

W

SPIDER 2 QR-111 L 2503-02-10- | Z | MAX 2 X 100W

LARK-111 | 12 V
 OPTIONS*

 50/60 Hz

COLOUR | Z ■ | MATERIAL | AL | » 452 * LARK-111 | 12 V » 453 | » 468





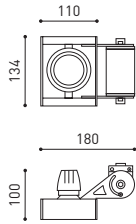

W

SPIDER 50 1

2526-11-00- | ZC |

MAX 1 X 50W

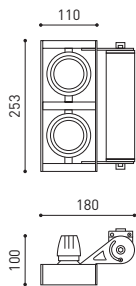

W

SPIDER 50 2

2526-12-00- | ZC |

MAX 2 X 50W



COLOUR | ZC ■ |

MATERIAL | AL ■ |

i » 452



W

SPIDER Suspension 1 QR-111 EXCL** 2305-71-00- | Z | MAX 1 X 100W

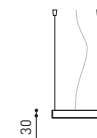

W

SPIDER Suspension 1 QR-111 2305-41-10- | Z | MAX 1 X 100W

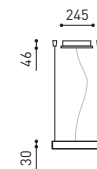

W

SPIDER Suspension 1 CDM-R111 2307-01-35- | Z | 1 X 35W
2307-01-07- | Z | 1 X 70W

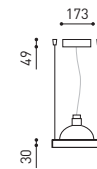
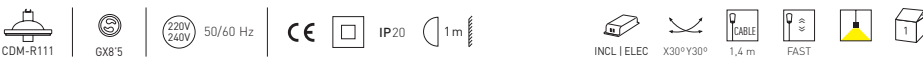

COLOUR | Z |

MATERIAL | AL | i » 452

* LARK-111 | 12V » 453 | » 468

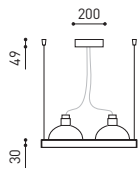
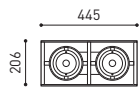
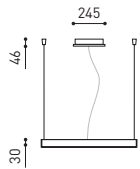
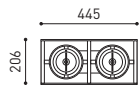
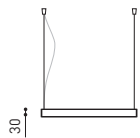
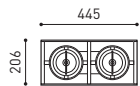

W

SPIDER Suspension 2 QR -111 EXCL** 2305-72-00- | Z | **MAX 2 X 100W**



W

SPIDER Suspension 2 QR-111 2305-42-05- | Z | **MAX 2 X 50W**



W

SPIDER Suspension 2 CDM-R111 2307-02-35- | Z | **2 X 35W**

2307-02-07- | Z | **2 X 70W**



****ACCESSORY Recessed Covering 1** 0826-00-00 | Z |









W

SPIDER Suspension 4 QR-111 C EXCL** 2305-74-00- | Z | **MAX 4 X 100W**

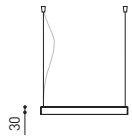
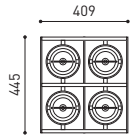

W

SPIDER Suspension 4 QR-111 C 2305-44-10- | Z | **MAX 4 X 100W**

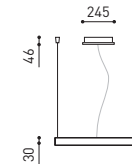
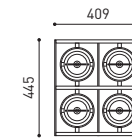

****ACCESSORY Recessed Covering 4** 0827-00-00 | Z |



COLOUR | Z ■ |

MATERIAL | AL | » 452

* LARK-111 | 12V » 453 | » 468









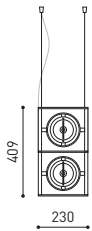

W

SPIDER Suspension 2 QR-111 V EXCL** 2306-72-00- | Z | **MAX 2 X 100W**

LARK-111 | 12V OPTIONS*

 1,5 m

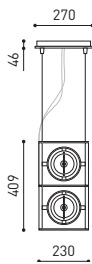

W

SPIDER Suspension 2 QR-111 V 2306-42-05- | Z | **MAX 2 X 50W**

LARK-111 | 12V OPTIONS*

 50/60 Hz

 1,5 m

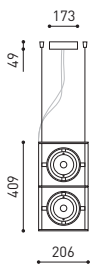

W

SPIDER Suspension 2 CDM-R111 V 2307-72-35- | Z | **2 X 35W**

50/60 Hz

 1,4 m



****ACCESSORY Recessed Covering 1** 0826-00-00 | Z |



COLOUR | Z ■ |

MATERIAL | AL | » 452

* LARK-111 | 12V » 453 | » 468

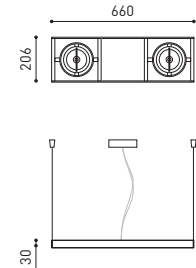

W

SPIDER Suspension 2 QR-111 L 2305-62-10- | Z | **MAX 2 X 100W**















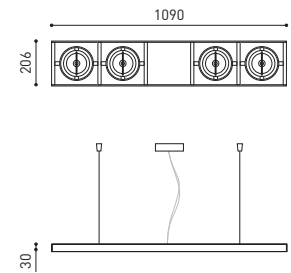

W

SPIDER Suspension 4 QR-111 2305-66-10- | Z | **MAX 4 X 100W**















COLOUR | Z ■ |





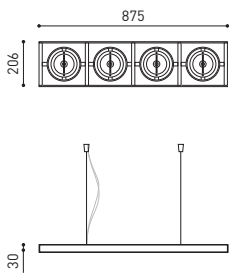









MATERIAL |  AL |  » 452

* LARK-111 | 12V  » 453 |  » 468



W





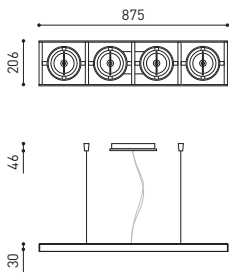







SPIDER Suspension 4 QR-111 L EXCL** 2305-75-00- | Z | **MAX 4 X 100W**



W

SPIDER Suspension 4 QR-111 L 2305-45-10- | Z | **MAX 4 X 100W**



****ACCESSORY Recessed Covering 4** 0827-00-00 | Z |



COLOUR | Z ■ |

MATERIAL |  AL |  » 452

* LARK-111 | 12V  » 453 |  » 468

BRIGIT SUSPENSION



BRIGIT SUSPENSION 0900-50-00- | W | R | N | MAX 4 X 23W

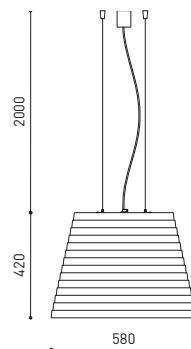

COLOUR | W □ | R ■ | N ■ | MATERIAL | PE | PC | ⓘ » 452





BRIGIT White



BRIGIT Red



BRIGIT Orange







Juan M. Jado - Fotografía de Arquitectura - www.photo.jaomorgado.com

Lab

gusto
D
(p1)
- (p0)
M
(p-1)

EPAL

Laboratório Central

C



uaT

unidade de apo

(p

(p

H S O



wall lights







AURAE 404



SLIM 408



LED WALL LIGHTS 410



ZOOM WALL 414



P220 WALL 418



COIN 422



VITUBER 422

NEW

AURAE



		W	K	Lm	%Eff
AURAE LED	A192-02-01- WT	12W	3000K	1050	79%
	A192-02-02- WT	12W	4200K	1150	79%

50/60 Hz

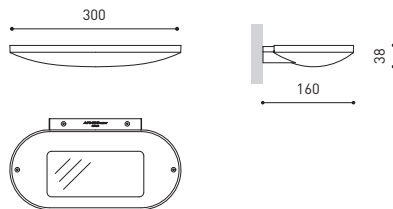

		W
AURAE R7S	A192-01-01- WT	MAX 230W

50/60 Hz

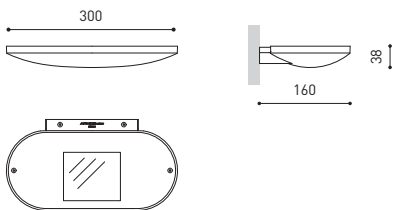

COLOUR | WT | MATERIAL | AL |

>> 452 | >> 468







SLIM



				K	W
SLIM 200	A040-01-02-	Z W		3000 K	3W
	A040-01-01-	Z W		4000 K	3W

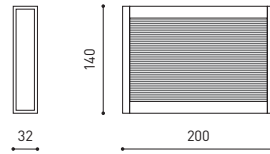

				K	W
SLIM 380	A040-02-02-	Z W		3000 K	6W
	A040-02-01-	Z W		4000 K	6W

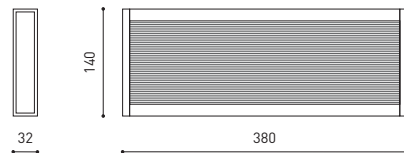

				K	W
SLIM 560	A040-03-02-	Z W		3000 K	9W
	A040-03-01-	Z W		4000 K	9W

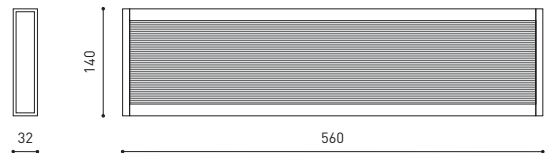

COLOUR | Z ■ | W □ | MATERIAL | AL |

» 452 | » 468



LED WALL LIGHTS

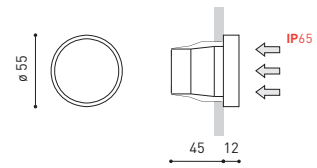

		mA	K	W
LED WALL LIGHT Alfa	A030-01-01- P	350	3000 K	4W
	A030-01-02- P	350	4000 K	4W

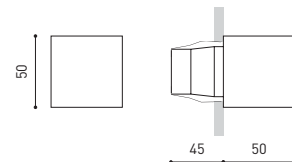

		mA	K	W
LED WALL LIGHT Beta D	A030-02-03- Z W	350	3000 K	4W
	A030-02-04- Z W	350	4000 K	4W



		mA	K	W
LED WALL LIGHT Beta S	A030-02-01- Z W	350	3000 K	4W
	A030-02-02- Z W	350	4000 K	4W



COLOUR | Z ■ | W □ | P ■ | MATERIAL | AL |

» 452 | » 468

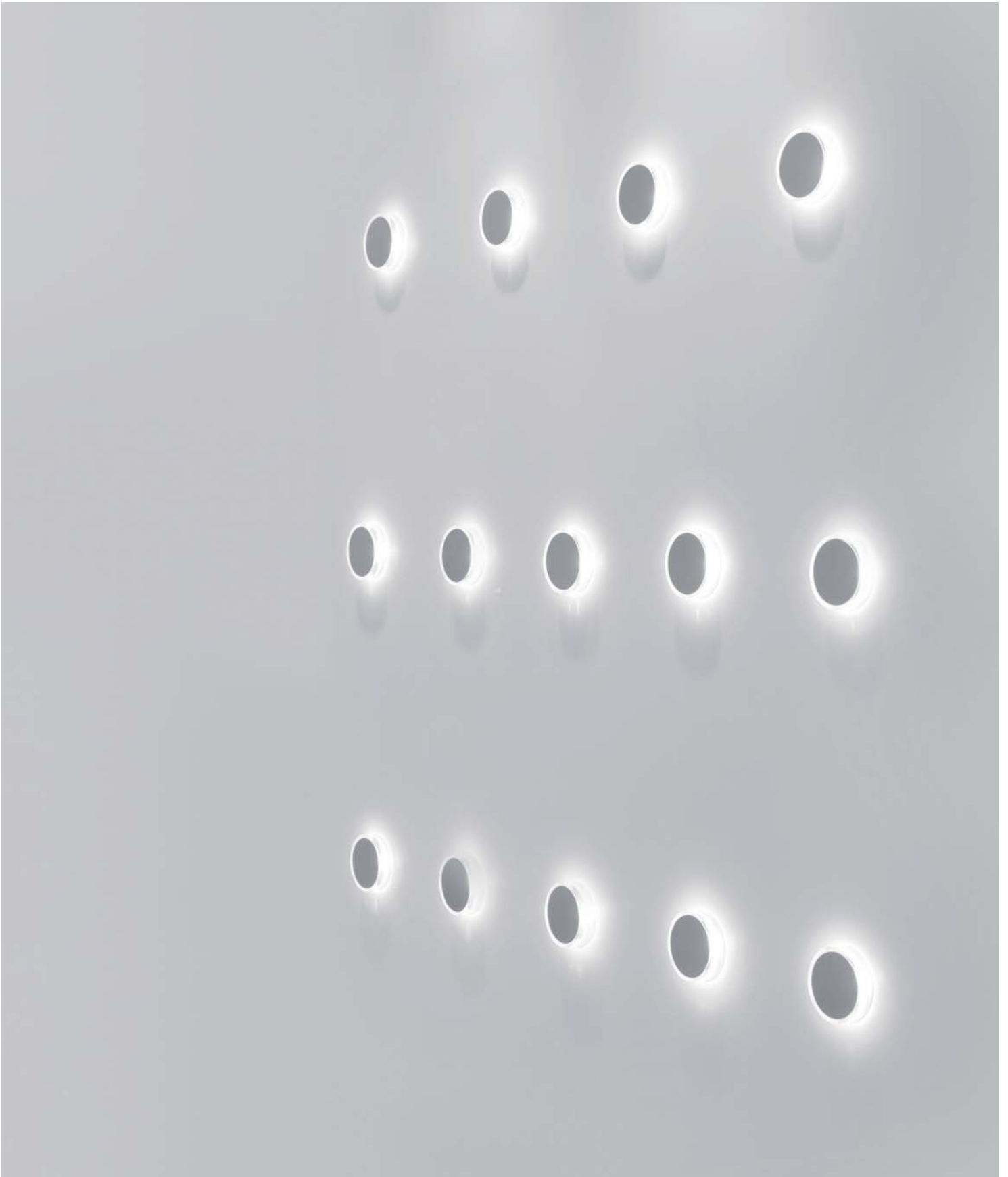

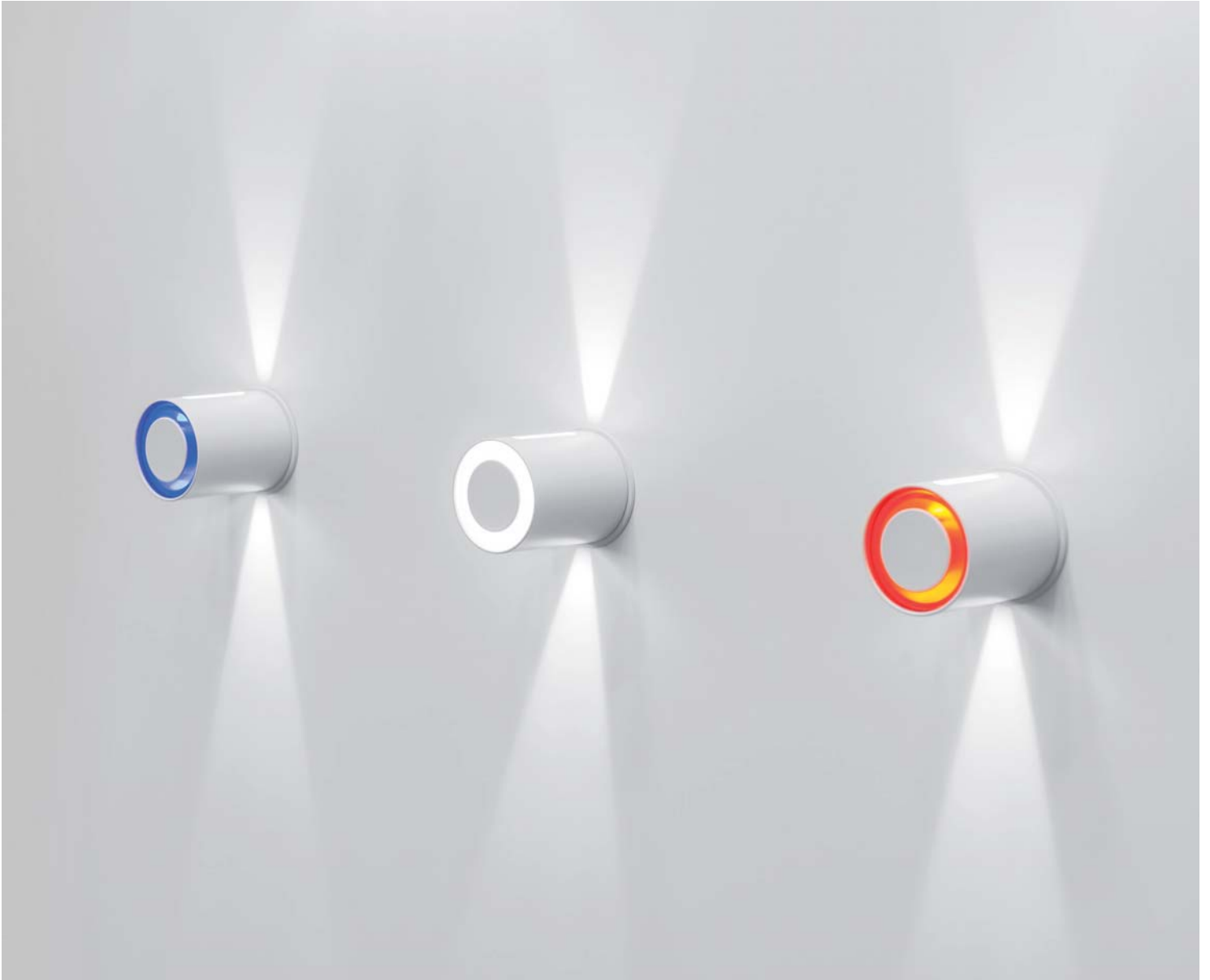

COLOUR | Z ■ | W □ | MATERIAL |  AL |

 » 452 |  » 468

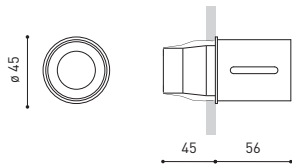

		mA	K	W
LED WALL LIGHT Gamma	A030-03-01- Z W	350	3000 K	2 X 1W
	A030-03-02- Z W	350	4000 K	2 X 1W

		mA	K	W
	A030-03-03- Z W	350	3000 K	2 X 1W
	A030-03-04- Z W	350	4000 K	2 X 1W

		mA	K	W
	A030-03-05- Z W	350	3000 K	2 X 1W
	A030-03-06- Z W	350	4000 K	2 X 1W

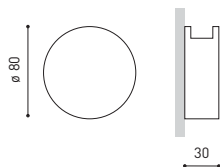
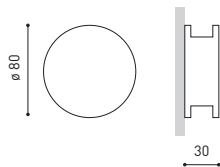

		K	W
LED WALL LIGHT Delta D	A030-04-03- Z W	3000 K	2 X 3W
	A030-04-04- Z W	4000 K	2 X 3W



		K	W
LED WALL LIGHT Delta S	A030-04-01- Z W	3000 K	1 X 3W
	A030-04-02- Z W	4000 K	1 X 3W



ZOOM WALL



		W	
ZOOM WALL Square S	2506-60-51- Z W	MAX 1 X 50W	
HI-SPOT ES 50 ALU GU10 220V/240V CE IP20 0.5m			

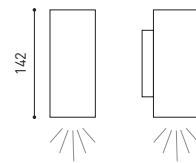

		W	
ZOOM WALL Square D	2506-60-52- Z W	MAX 2 X 50W	
HI-SPOT ES 50 ALU GU10 220V/240V CE IP20 0.5m			

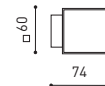
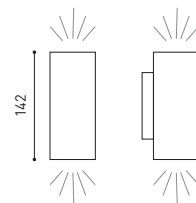

COLOUR | Z ■ | W □ |

MATERIAL | AL | » 452







W

ZOOM WALL Round S 2504-60-51- | Z | W | MAX 1 X 50W

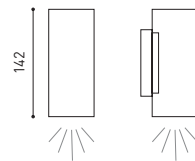

W

ZOOM WALL Round D 2504-60-52- | Z | W | MAX 2 X 50W

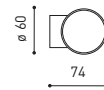
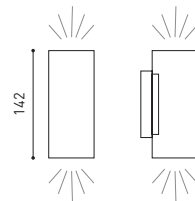

COLOUR | Z ■ | W □ |

MATERIAL | AL | ⓘ » 452



NEW

P220 WALL

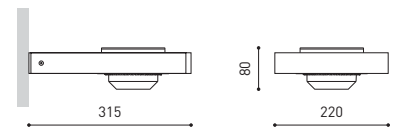

W

P220 WALL Lark-111

REFERENCE PLEASE CONSULT

MAX 15W

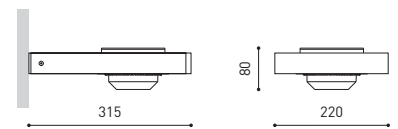

W

P220 WALL QR-111

2601-46-01- | Z | W |

MAX 50W



COLOUR | Z ■ | W □ |

MATERIAL | AL |

* LARK 111 | 12V & ** LARK 111 OPTIONS » 453 | » 468





Adriana F. Lopez - Barajas | Estudio de interiorismo - www.adrianaolopezbarajas.com



			W
P220 WALL CDM-R111	2601-47-35- Z W		35W
	2601-47-07- Z W		70W

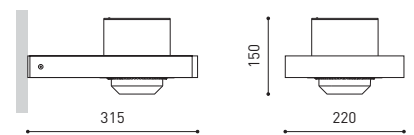

COLOUR | Z ■ | W □ | MATERIAL | AL

i » 452

COIN & VITUBER



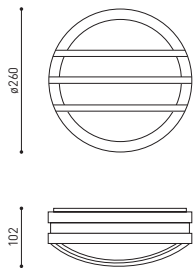

W

COIN Lines* 5514-00-00- | ZE | MAX 60W

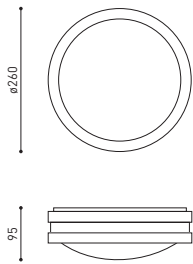

W

COIN Full* 5515-00-00- | ZE | MAX 60W

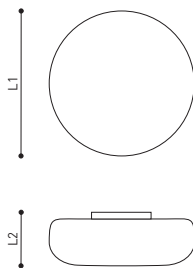

		L1	L2	W
VITUBER**	0502-20-00	200	110	MAX 60W
	0502-25-00	250	120	MAX 60W



*COLOUR | ZE ■ |

*MATERIAL | AL | PC-MATT |

**MATERIAL | GLASS | » 452



floor





P220 FLOOR 428



BRIGIT 434



STAR 438

NEW

P220 FLOOR

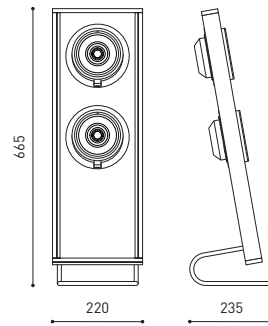

W

P220 FLOOR **Lark-111** REFERENCE PLEASE CONSULT **MAX 2 X 15W**



CE  IP20 | CRI>80

COLOUR | Z ■ | W □

MATERIAL |  AL |  » 452

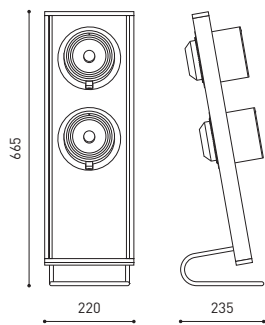

W

P220 FLOOR QR-111

2601-48-02- | Z | W |

MAX 2 X 50W



QR-111

LED

LARK-111 | 12 V
OPTIONS*



G53



220V
240V

50/60 Hz



PLUG | CONNEX



INCL | ELEC



355°



90°



1



1



IP20



* LARK 111 | 12V  & ** LARK 111 OPTIONS » 453 |  » 468







COLOUR | Z ■ | W □ |

MATERIAL |  AL |  » 452

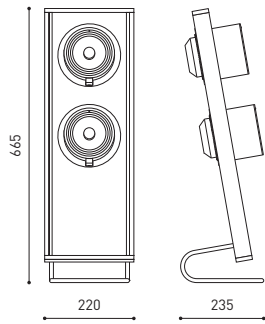

				W
P220 FLOOR CDM-R111	2601-49-35-	Z W		2 X 35W
	2601-49-07-	Z W		2 X 70W



CDM-R111



GX85



220V
240V

50/60 Hz



PLUG | CONNEX



INCL | ELEC



355°



90°



IP20



1m

BRIGIT



		W	
BRIGIT	0900-00-00-	WT	MAX 4 X 23W



		W	
BRIGIT Master LED RGB+W	0900-00-05-	WT	INCL 45W
BRIGIT Slave LED RGB+W	0900-00-06-	WT	EXCL 45W



ACCESSORY Fixing Floor	0900-00-01
-------------------------------	-------------------

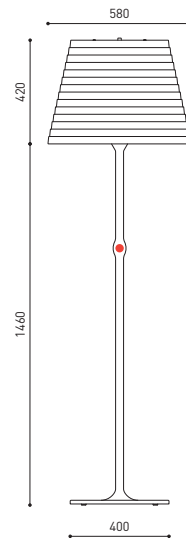

COLOUR | WT □ | MATERIAL | AL + PE |

» 452

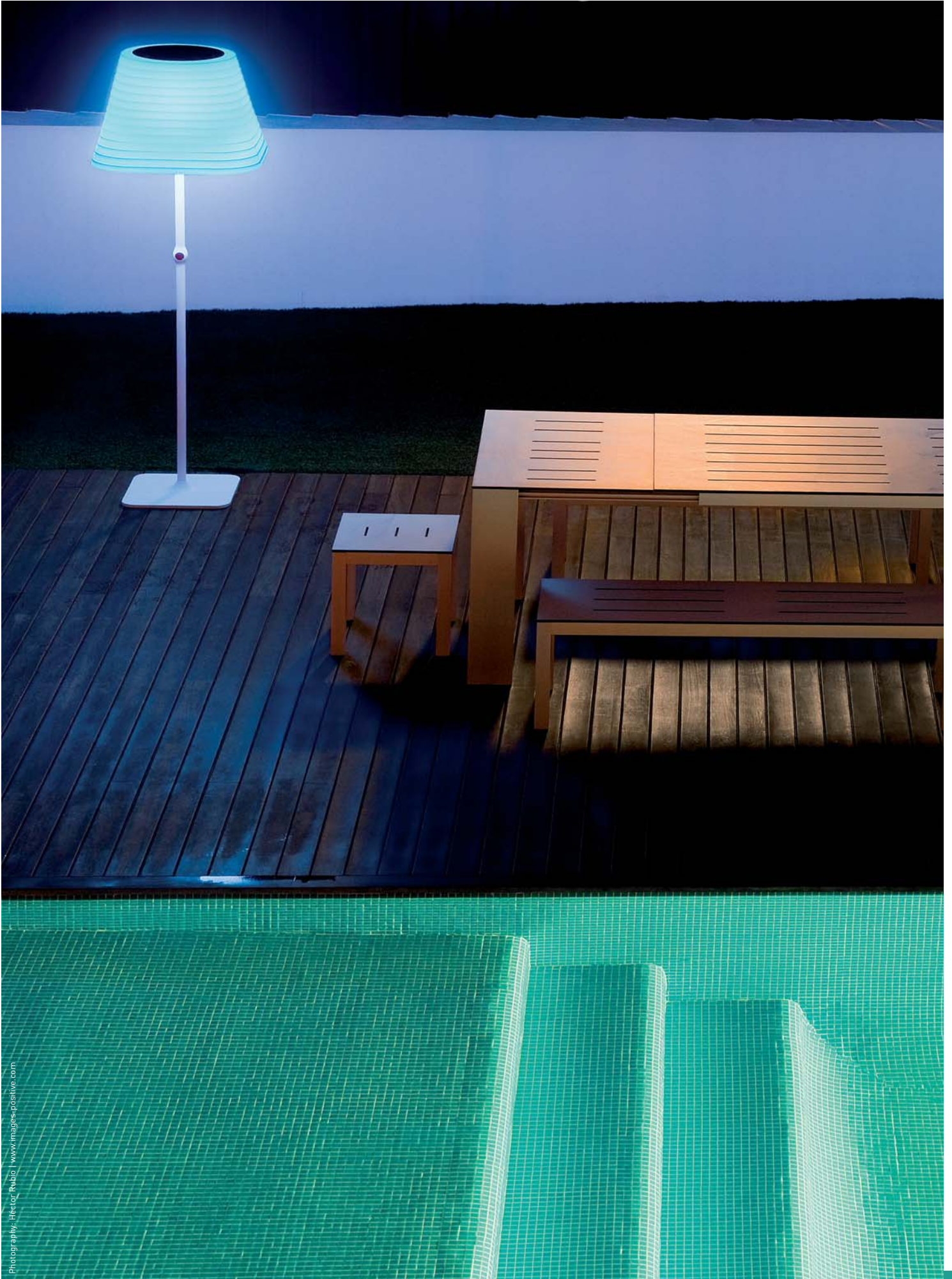



Photography: Héctor Rubio | www.images-positive.com



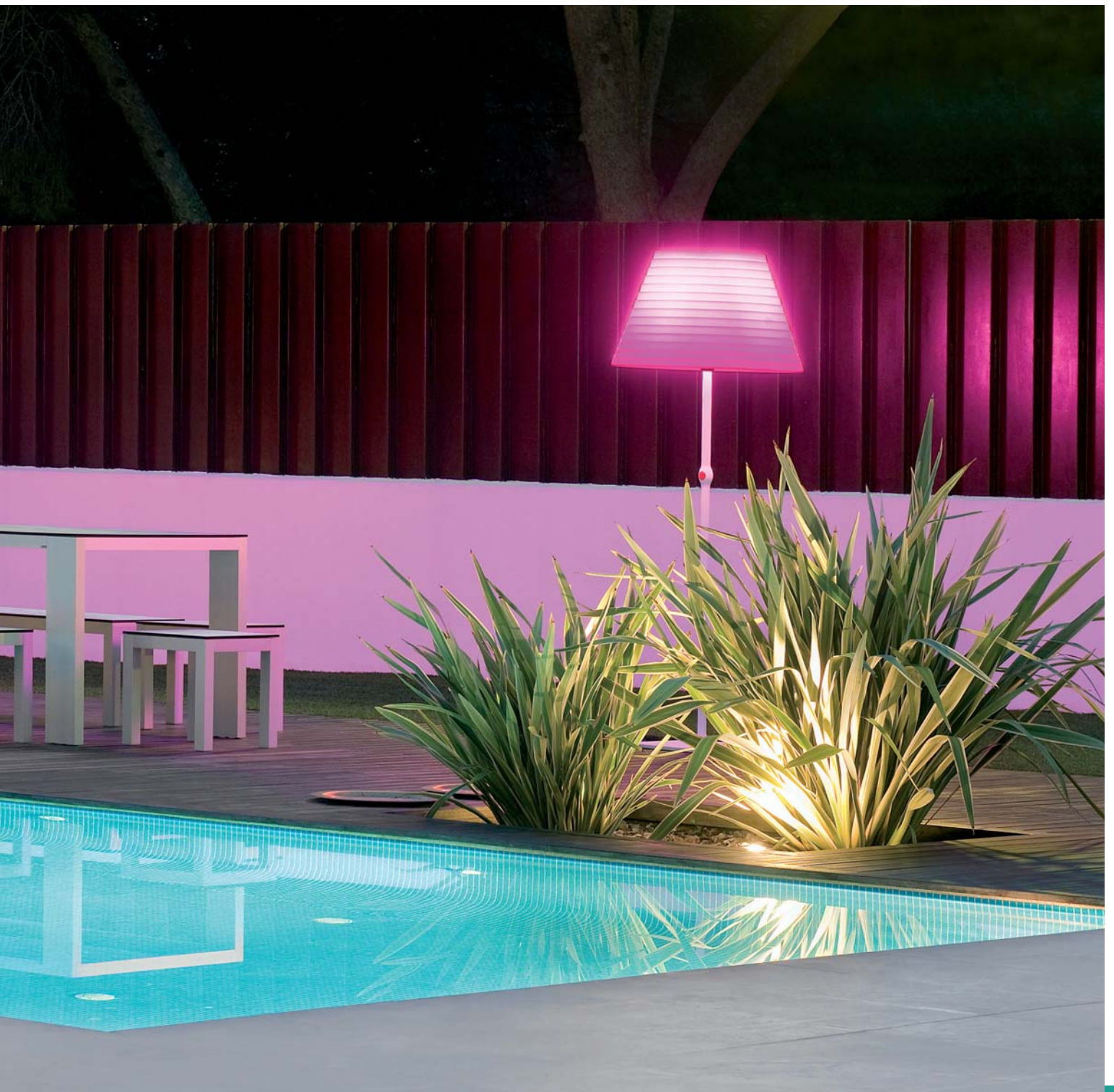

STAR

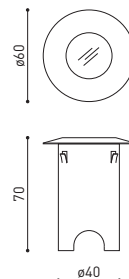

			mA	K	W
STAR LED 60	5800-60-01- NX		350	4000 K	1W
	5800-60-02- NX		350	BLUE	1W



BOX INCLUDED

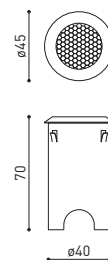
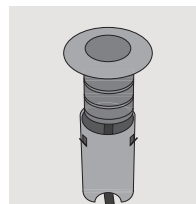

				K	W
STAR LED 45	5800-45-01- NX			3000 K	0,3W
	5800-45-02- NX			BLUE	0,3W



BOX INCLUDED

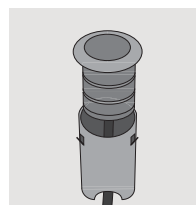

COLOUR | NX ■ | MATERIAL | INOX |

> 452

Photography: James Silverman - www.jamesilverman.co.uk





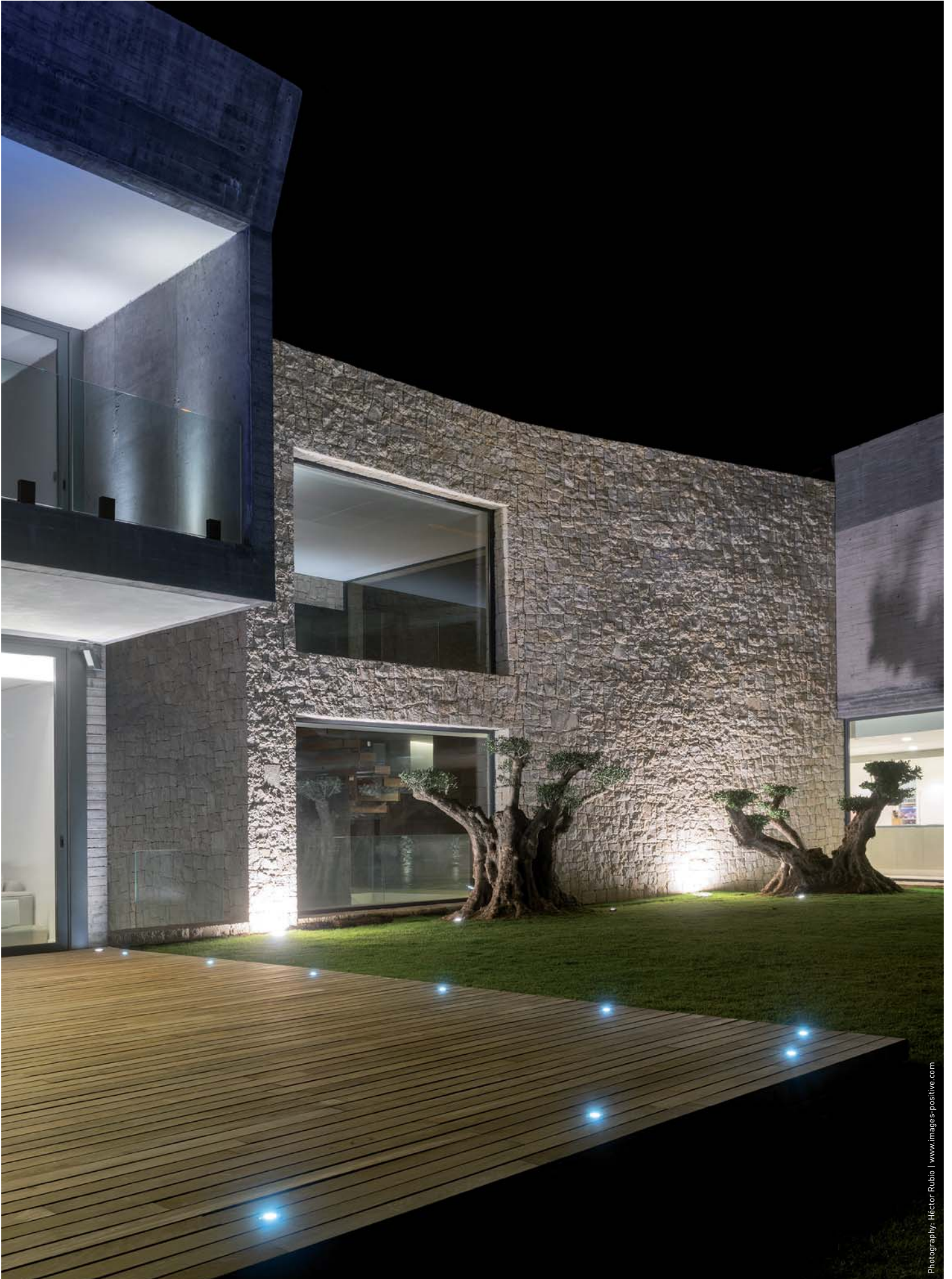

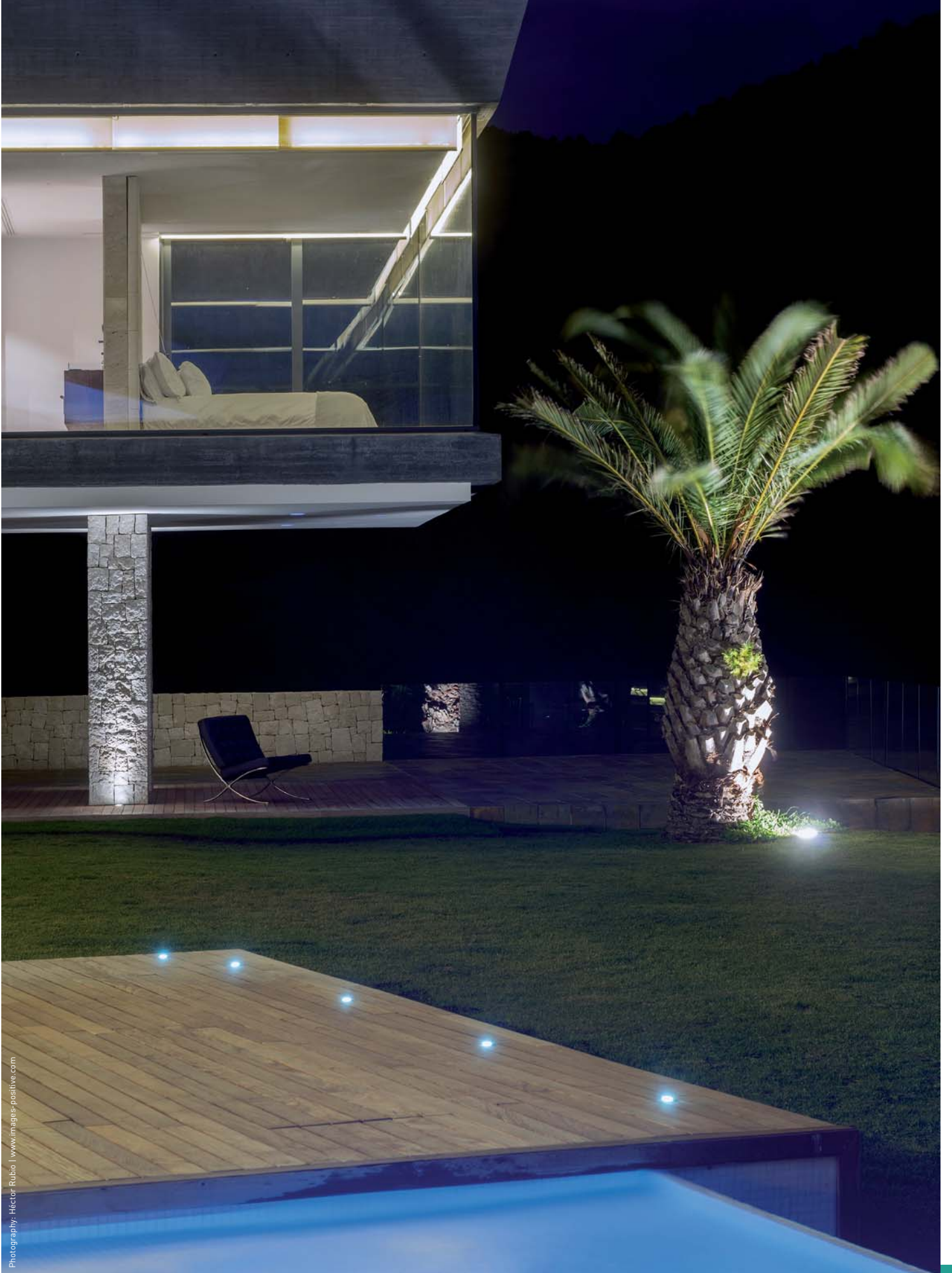

Photography: Héctor Rubio | www.images-positive.com









Photography: Héctor Rubio | www.images-positive.com



			W	
STAR GU-10	5810-00-00-	NX	GL-TRANS	MAX 35W
	5810-01-00-	NX	GL-MATT	MAX 35W

HI-SPOT ES 50 |
 GU10 |
 220V/240V |
 CE |
 |
 IP65 |
 IK09 |
 0.5m |
 MAX 25 Km/h |
 MAX 2000 Kg |
 140° C |
 Ø100 |
 |
 |
 OUTDOOR

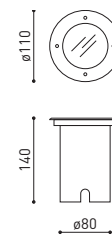

BOX INCLUDED

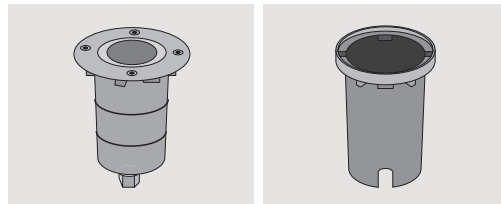

COLOUR | NX ■ | MATERIAL | INOX | » 452

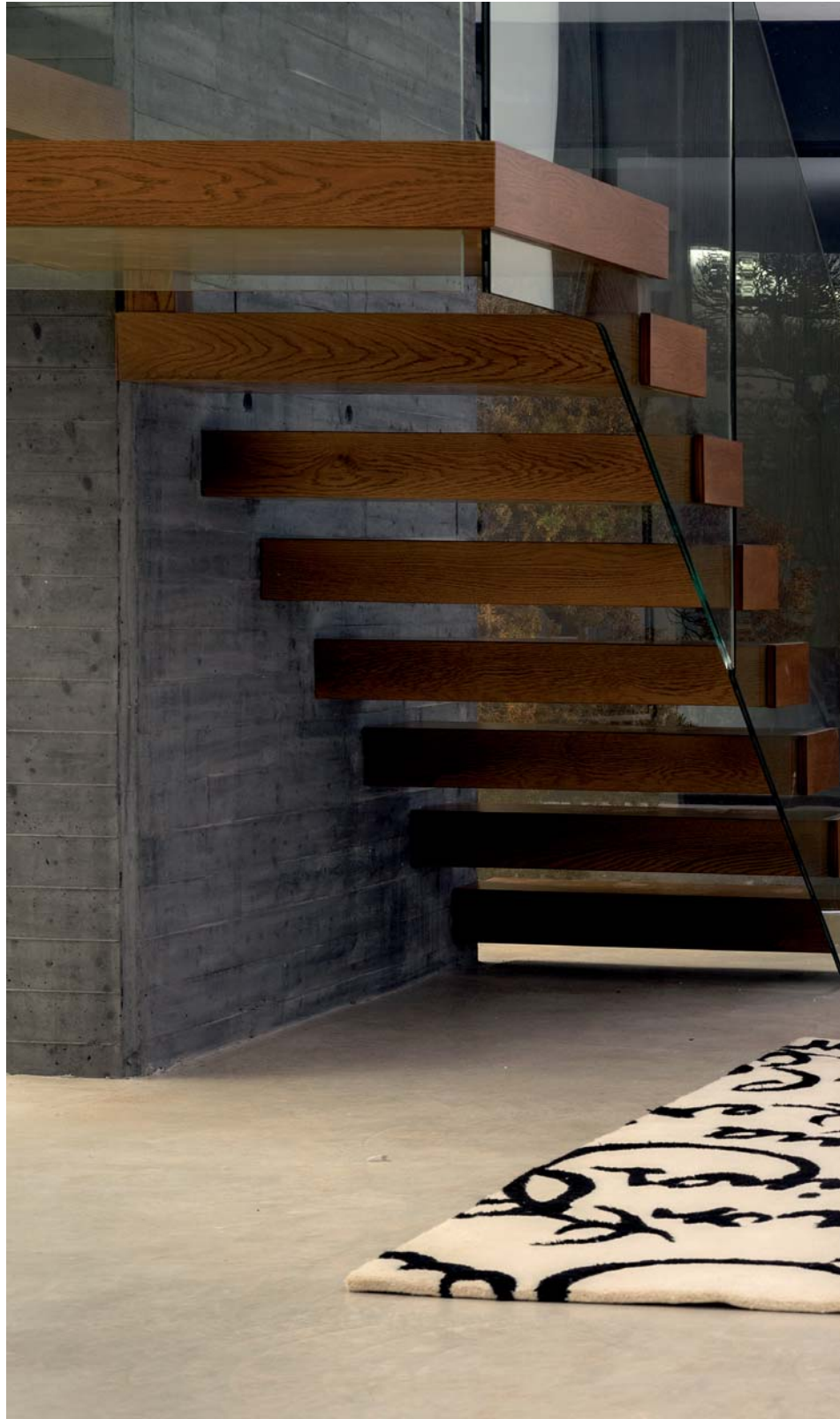







info &



accessories



ACCESSORIES



Lark® by ARKOSLIGHT®

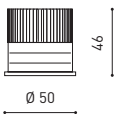

					K*	h	Lm
LARK 5W	500mA	0433-00-34		+ DRIVER LED	3000K	25000	415

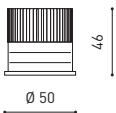

LARK 8W	200mA	0434-00-05		+ DRIVER LED	3000K	25000	625
LARK 8W	200mA	0434-00-06		+ DRIVER LED	3000K	25000	625

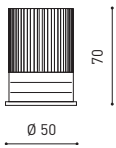

LARK 11W	300mA	0434-00-09		+ DRIVER LED	3000K	25000	843
LARK 11W	300mA	0434-00-15		+ DRIVER LED	3000K	25000	843



CE CRI>80

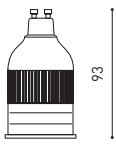

					⊙	K	h	Lm
LARK 5W	GU10	0433-00-83			GU10	3000K	25000	415
LARK 8W	GU10	0433-00-80			GU10	3000K	25000	607
LARK 8W	GU10	0433-00-81			GU10	3000K	25000	607



CE CRI>80



*OTHER COLOUR TEMPERATURE PLEASE CONSULT

**OTHER BEAM PLEASE CONSULT



>> 468



Lark®-111 by ARKOSLIGHT®

					W	K	Lm	%Eff	BEAM
500mA	A202-11-11- W N Z		+ DRIVER LED		10,5W	3000K	1070	94%	24°
	A202-11-21- W N Z		+ DRIVER LED		10,5W	3000K	1070	92%	50°
700mA	A202-22-11- W N Z		+ DRIVER LED		15W	3000K	1440	94%	24°
	A202-22-21- W N Z		+ DRIVER LED		15W	3000K	1440	92%	50°
700mA	A202-23-11- W N Z	▲	+ DRIVER LED		15W	3000K	1440	94%	24°
	A202-23-21- W N Z	▲	+ DRIVER LED		15W	3000K	1440	92%	50°

LED | UPDATE | 220V/240V 50/60 Hz | CE CRI>80

PHASE CUT | INCL | ELEC | 1

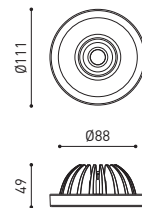

COLOUR | Z ■ | W □ | N ■ |



Lark®-111 | 12V by ARKOSLIGHT®





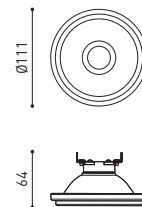







	W	K	h	⊙	Lm	%Eff	BEAM
0434-00-69	12	3000	45000	G53	980	75%	35°



LED | UPDATE | 12V | CE CRI>80









1

MATERIAL | AL | 468

			W	K	h	☉	V	B	Cd	Lm
QT-9		0414-20-00	20	2800	2000	G4	12			300
QT-12		0414-50-00	50	2800	2000	GY6,35	12			900
QR-CBC 51		0412-50-38	50	3000	3000	GU5,3	12	38°	1450	
		0412-50-60	50	3000	4000	GU5,3	12	60°	800	
HI-SPOT ES 50 ALU		0444-00-00-GU	50	2900	2000	GU10	230	35°	950	
		0444-00-35	35	2700	2000	GU10	230	35°	570	
QR-111		0449-50-08	50	3000	3000	G53	12	8°	23000	
		0449-50-24	50	3000	3000	G53	12	24°	4000	
		0449-10-24	100	3000	3000	G53	12	24°	8500	
		0449-10-45	100	3000	3000	G53	12	45°	2800	
QR-111 IRC		0450-30-08	30	3000	4000	G53	12	8°	23000	
		0450-30-24	30	3000	4000	G53	12	24°	4000	
		0450-45-08	45	3000	4000	G53	12	8°	33000	
		0450-45-24	45	3000	4000	G53	12	24°	5300	
		0450-45-45	45	3000	4000	G53	12	45°	1900	
		0450-60-08	60	3000	4000	G53	12	8°	48000	
		0450-60-24	60	3000	4000	G53	12	24°	8500	
0450-60-45	60	3000	4000	G53	12	45°	2800			
PAR 25		0451-50-00-10	50	2900	2500	E27	230	10°	4000	
		0451-50-00-25	50	2900	2500	E27	230	25°	1100	
		0451-75-00-10	75	2900	3000	E27	230	10°	5500	
		0451-75-00-25	75	2900	3000	E27	230	25°	1300	
PAR 30		0463-75-00-10	75	2900	3000	E27	230	10°	6900	
		0463-75-00-30	75	2900	3000	E27	230	30°	2200	
		0463-10-00-10	100	2900	3000	E27	230	10°	10000	
		0463-10-00-30	100	2900	3000	E27	230	30°	3500	
TC - DEL		0417-10-30	10	3000	12000	G24q-1				600
		0417-10-40	10	4000	12000	G24q-1				600
		0417-13-30	13	3000	12000	G24q-1				900
		0417-13-40	13	4000	12000	G24q-1				900
		0417-18-30	18	3000	12000	G24q-2				1200
		0417-18-40	18	4000	12000	G24q-2				1200
		0417-26-30	26	3000	12000	G24q-3				1800
0417-26-40	26	4000	12000	G24q-3				1800		
TC - TEL		0477-18-30	18	3000	10000	GX24q-2				1200
		0477-18-40	18	4000	10000	GX24q-2				1200
		0477-26-30	26	3000	10000	GX24q-3				1800
		0477-26-40	26	4000	10000	GX24q-3				1800
		0477-32-30	32	3000	10000	GX24q-3				2400
		0477-32-40	32	4000	10000	GX24q-3				2400
		0477-42-30	42	3000	10000	GX24q-4				3200
0477-42-40	42	4000	10000	GX24q-4				3200		
MICROLYNX		0479-07-30	11	3000	1000	GX53	230			220
		0479-07-40	11	4000	1000	GX53	230			220



W Potencia | Wattage
K Temperatura de color | Color temperature
h Vida media | Life span
☉ Casquillo | Socket

V Tensión | Voltage
B Ángulo | Beam
Cd Intensidad | Intensity
Lm Flujo luminoso | Luminous flux

			W	K	h	☉	V	B	Cd	Lm
T5 LUMILUX SEAMLESS		0467-90-01	24	3000	24000	G5				1750
		0467-90-02	24	4000	24000	G5				1750
		0467-90-03	39	3000	24000	G5				3100
		0467-90-04	39	4000	24000	G5				3100
		0467-90-05	54	3000	24000	G5				4450
		0467-90-06	54	4000	24000	G5				4450
T5		0467-24-30	24	3000	24000	G5				2000
		0467-24-40	24	4000	24000	G5				2000
		0467-39-30	39	3000	24000	G5				3500
		0467-39-40	39	4000	24000	G5				3500
		0467-54-30	54	3000	24000	G5				5000
		0467-54-40	54	4000	24000	G5				5000
		0467-80-30	80	3000	24000	G5				7000
		0467-80-40	80	4000	24000	G5				7000
		0495-14-30	14	3000	20000	G5				1350
		0495-14-40	14	4000	20000	G5				1350
		0495-21-30	21	3000	20000	G5				2100
		0495-21-40	21	4000	20000	G5				2100
		0495-28-30	28	3000	20000	G5				2900
		0495-28-40	28	4000	20000	G5				2900
0495-35-30	35	3000	20000	G5				3650		
0495-35-40	35	4000	20000	G5				3650		
T5 FC		0467-55-30	55	3000	16000	2GX13				4200
		0467-55-40	55	4000	16000	2GX13				4200
HIT-DE		0428-70-00-C	70	3000	9000	RX7s				6200
		0429-70-00-F	70	4200	9000	RX7s				6200
		0430-15-00-C	150	3000	9000	RX7s				12500
		0421-15-00-F	150	4200	9000	RX7s				12500
HIT-DE CONSTANT COLOR		0436-70-29	70	3000	9000	RX7s				6800
		0436-70-43	70	4200	9000	RX7s				6500
		0436-15-29	150	3000	9000	RX7s				14500
		0436-15-43	150	4200	9000	RX7s				14400
R7S ECO	 114,2 mm	0434-00-74	120	3000	2000	R7s	230			2250
		0434-00-75	160	3000	2000	R7s	230			3100
		0434-00-76	230	3000	2000	R7s	230			5000
SDW -TG		0415-50-00	50	2500	8000	GX12-1				2400
		0415-10-00	100	2500	8000	GX12-1				4900
HIT G8,5		0468-20-30	20	3000	1200	G8,5				1800
		0468-35-30	35	3000	9000	G8,5				3100
		0468-35-42	35	4200	9000	G8,5				3100
		0468-70-30	70	3000	15000	G8,5				6200
		0468-70-42	70	4200	15000	G8,5				6200
HIT G12 CONSTANT COLOR		0469-35-30	35	3000	9000	G12				3150
		0469-35-42	35	4200	9000	G12				3150
		0475-70-31	70	3000	9000	G12				6600
		0469-70-42	70	4200	9000	G12				6600
		0475-15-31	150	3000	9000	G12				14000
		0469-15-42	150	4200	9000	G12				12700

























W Potencia | Wattage
K Temperatura de color | Color temperature
h Vida media | Life span
☉ Casquillo | Socket

V Tensión | Voltage
B Ángulo | Beam
Cd Intensidad | Intensity
Lm Flujo luminoso | Luminous flux

				K	h	⊕	V	B	Cd	Lm
PAR 30 CDM-R		0465-35-00-10	35	3000	12000	E27		10°	45000	
		0465-35-00-30	35	3000	6000	E27		30°	8000	
		0465-70-00-10	70	3000	6000	E27		10°	70000	
		0465-70-00-30	70	3000	6000	E27		30°	13500	
		0465-70-42-10	70	4200	6000	E27		10°	70000	
		0465-70-42-40	70	4200	6000	E27		40°	9000	
CDM-R111		0437-20-10	20	3000	10000	GX 8,5		10°	20000	650
		0437-20-24	20	3000	10000	GX 8,5		24°	4500	650
		0437-35-10	35	3000	10000	GX 8,5		10°	35000	1100
		0437-35-24	35	3000	10000	GX 8,5		24°	8500	1350
		0437-35-40	35	3000	10000	GX 8,5		40°	4000	1350
		0437-70-10	70	3000	10000	GX 8,5		10°	50000	2500
		0437-70-24	70	3000	10000	GX 8,5		24°	15000	2850
		0437-70-40	70	3000	10000	GX 8,5		40°	9000	2850

- W** Potencia | Wattage
- K** Temperatura de color | Color temperature
- h** Vida media | Life span
- ⊕** Casquillo | Socket
- V** Tensión | Voltage
- B** Ángulo | Beam
- Cd** Intensidad | Intensity
- Lm** Flujo luminoso | Luminous flux
- Hz** Frecuencia | Frequency

EQUIPMENTS

HALOGEN LAMPHOLDER GX5,3 Portalámparas Halógeno GX5,3		0418-00-00	MAX 50W			  
HALOGEN LAMPHOLDER GZ10 Portalámparas Halógeno GZ10		0419-00-00	MAX 50W			  
ELECTRONIC TRANSFORMER Transformador Electrónico		0440-00-00 0448-00-00	60W 105W	 Phase Cut  Phase Cut	100 x 30 x 20 mm 125 x 34 x 21 mm	  
ELECTRONIC TRANSFORMER + Cable Transformador Electrónico + Cable		0440-20-00	60W	 Phase Cut	125 x 34 x 21 mm	  
SAFETY SEPARATOR Distanciador		0458-00-00	with connection box covered			
ELECTRONIC STARTER Arrancador Electrónico		0474-00-35 0474-00-07 0474-00-15	35W 70W 150W	metal halide metal halide metal halide	150 x 79 x 34 mm	  

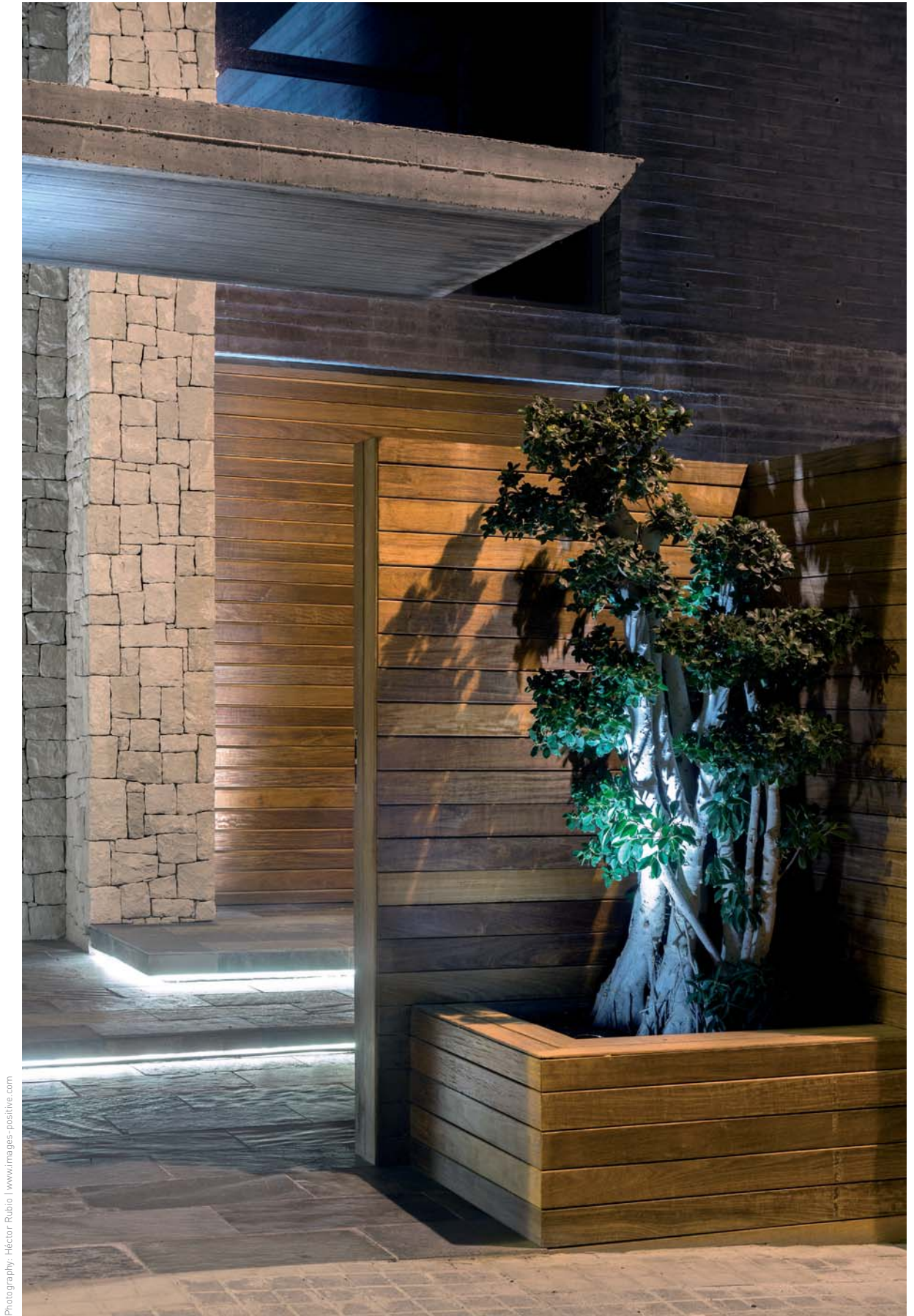

Photography: Héctor Rubio | www.images-positive.com



Photography: Joao Morgado - Fotografia de Arquitectura - www.photo.joamorgado.com

Flexible LED Strip





		D	Lm	Lamp	W/m	✂	●●	W	Vdc	IP
LED STRIP IP20	0432-00-09	5 m x 8 mm	1140	Led 3528	5	5 cm	3000 K ±10%	25	12	IP20
LED STRIP IP20	0432-00-10	5 m x 8 mm	1290	Led 3528	5	5 cm	4000 K ±10%	25	12	IP20
LED STRIP IP20	0432-00-11	5 m x 10 mm	4500	Led 5050	14	5 cm	3000 K ±10%	72	12	IP20
LED STRIP IP20	0432-00-12	5 m x 10 mm	4950	Led 5050	14	5 cm	4000 K ±10%	72	12	IP20
LED STRIP IP20	0432-00-13	5 m x 10 mm	...	Led 5050	13	5 cm	RGB	64	12	IP20
LED STRIP IP65	0432-00-14	5 m x 8 mm	1100	Led 3528	5	5 cm	3000 K ±10%	25	12	IP65
LED STRIP IP65	0432-00-15	5 m x 8 mm	1200	Led 3528	5	5 cm	4000 K ±10%	25	12	IP65
LED STRIP IP65	0432-00-16	5 m x 10 mm	4300	Led 5050	14	5 cm	3000 K ±10%	72	12	IP65
LED STRIP IP65	0432-00-17	5 m x 10 mm	4950	Led 5050	14	5 cm	4000 K ±10%	72	12	IP65
LED STRIP IP65	0432-00-18	5 m x 10 mm	...	Led 5050	13	5 cm	RGB	64	12	IP65

Control remoto, consultar | Remote control, please consult



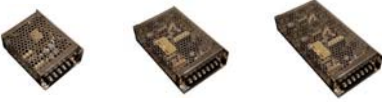



- D** Dimensiones | Dimensions
- Lm** Lúmenes | Lumen
- Lamp** Lámpara | Lamp
- W/m** Potencia por metro | Voltage per meter
- ✂** Divisible | Divisible
- Color Led | Led Color
- W** Potencia | Wattage
- Vdc** Tensión | Voltage
- IP** Estanqueidad | Sealing









Constant Voltage Led Power Supply

			W	V	D
		0401-05-12	MAX 50W	12V	111 x 36 x 80 mm
		0401-10-12	MAX 100W	12V	160 x 38 x 98 mm
		0401-15-12	MAX 150W	12V	200 x 38 x 100 mm
	 1-10V	IP67 0433-00-24	MAX 60W	12V	163 x 43 x 32 mm
		IP67 0434-00-71	MAX 25W	12V	148 x 40 x 32 mm
	 1-10V	IP20 0486-20-00	MAX 25W	12V	146 x 55 x 19 mm

Constant Current Led Driver

			W	mA	D
		0486-04-35	MAX 4W	350 mA	61 x 35 x 21 mm
		0486-08-35	MAX 8W	350 mA	61 x 35 x 21 mm
		0486-06-70	MAX 6W	700 mA	42 x 40 x 22 mm
		0486-12-70	MAX 12W	700 mA	115 x 34 x 19 mm
		IP68 0486-17-70	MAX 17W	700 mA	Ø100 x 80 mm
	 DALI PUSH	0434-00-70	MAX 8W	200 mA	105 x 70 x 28 mm

Multifunction Equipments

	 1-10V Push	0486-00-00	15W / 350 mA	103 x 67 x 21 mm
	 1-10V DALI PUSH	0434-00-73	22W / 500 mA 25W / 700 mA 10W / 12 V 20W / 24 V	
	 1-10V Push	0486-11-00	25W / 350 mA	123 x 67 x 21 mm
	 1-10V DALI PUSH	0433-00-23	35W / 500 mA	
			50W / 700 mA	
			50W / 900 mA	
			50W / 1050 mA 50W / 48 V	



Aluminium LED Profile



LED Profile Corner Kit

0434-00-11

Aluminium Profile

5 x 2 m

Diffuser Matt

5 x 2 m

Fixing Clips

20

End Caps

20

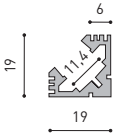

LED Profile Recessed Kit

0434-00-12

5 x 2 m

5 x 2 m

0

20

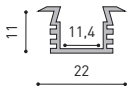

LED Profile Recessed Slim Kit

0434-00-13

5 x 2 m

5 x 2 m

0

20

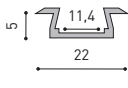

LED Profile Surface Kit

0434-00-14

5 x 2 m

5 x 2 m

0

20

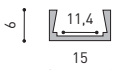

MATERIAL |  AL |  PC |



ARK-control

DALI ARK-TOUCH-SENSITIVE



TOUCH-SENSITIVE DALI PANEL
PANTALLA TÁCTIL DALI

12/36Vdc | CE III

0476-00-00

DALI POWER SUPPLY
ALIMENTADOR PARA EQUIPOS Y MÓDULOS DALI

0476-50-00 MAX 250mA | 300 m



3 CHANNEL PWM AMPLIFIER
AMPLIFICADOR PWM 3 CANALES

0432-00-72 MAX 2A X 3Ch



DALI CONTROLLER WITH 3 PWM CHANNEL OUTPUT
CONTROLADOR DALI CON SALIDA DE 3 CANALES PWM

0432-00-71 MAX 0,6A X 3Ch



RGB TOUCH-SENSITIVE WIRELESS CONTROLLER



WIRELESS TOUCH-SENSITIVE CONTROLLER RGB
CONTROLADOR RGB TÁCTIL INALÁMBRICO

0432-00-45 12/24Vdc | MAX 3A X 3Ch



RGB LED AMPLIFIER | AMPLIFICADOR PARA SISTEMAS LED RGB
Input/output 12/24Vdc constant voltage | Entrada / Salida 12V/24Vdc tensión constante

0432-00-58



12/24Vdc | MAX 6A X 3Ch



RGB-Y TOUCH-SENSITIVE WIRELESS CONTROLLER



RF WIRELESS TOUCH-SENSITIVE RGB-Y
EMISOR TÁCTIL DE RADIOFRECUENCIA RGB-Y

0432-00-25



4 CHANNEL RGB-Y CONTROLLER
Input/output 12-36Vdc constant voltage

0432-00-26

4Ch X 3A

RECEPTOR Y CONTROLADOR 4 CANALES RGB-Y
Voltaje de Entrada/ Salida: 12-36Vdc



iOS & ANDROID TOUCH CONTROLLERS

FULL TOUCH RGBY RF / WI-FI / BLUETOOTH
Control táctil RGBY RF / Wi-Fi / Mando Bluetooth



0434-00-62

LED CONTROLLER 12-36Vdc
Control LED 12-36Vdc



0434-00-63

4Ch X 3A

DIMMERS

PUSH DIMMER DIM 7-100W
Dimmer de pulsación DIM 7-100W

0434-00-58



ROTARY DIMMER 4-100W
Dimmer de rueda 4-100W

0434-00-59



LED DIMMER 3-400W
Dimmer LED 3-400W

0434-00-60



POTENTIOMETER 1-10V / MAX 30mA
Potenciómetro 1-10V / Max 30mA

0434-00-61



LED EMERGENCY KITS

1 HOUR EMERGENCY KIT
Batteries and green LED indicator included

KIT DE EMERGENCIA 1 HORA
Baterías e indicador LED verde incluidos
0434-00-64 Output 0-60Vdc | Salida 0-60Vdc



3 HOURS EMERGENCY KIT
Batteries and green LED indicator included

KIT DE EMERGENCIA 3 HORAS
Baterías e indicador LED verde incluidos
0434-00-65 Output 0-60Vdc | Salida 0-60Vdc



SENSORS

DALI MULTISENSOR
Ambient light dependent control and motion detection

MULTISENSOR DALI
Regula la intensidad lumínica en función de la luz ambiental y la detección de movimiento

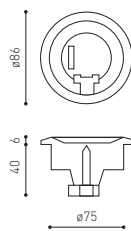

0434-00-66



3 POSITION SWITCH
On, Blue, Off

INTERRUPTOR DE 3 POSICIONES
Encendido, Blue, Apagado
0434-00-68



LIGHT SENSOR 1-10V / MAX 10mA
Sensor de Luz 1-10V / Max 10mA



0434-00-67



LEX SWITCH

Technical Info

COLOURS

Acabados disponibles (según modelo)
Available finishings (depending on the models)

- B Blanco | White
- WT Blanco texturado | Textured white
- W Blanco mate | Matt white
- NT Negro texturado | Textured black
- N Negro mate | Matt black
- Z Aluminio | Aluminium
- C Cromo | Chrome
- NS Níquel satinado | Brushed steel
- Q Cromo mate | Matt chrome
- P Anodizado plata mate satinado
Brushed silver matt anodized
- NX Acero Inoxidable | Stainless Steel
- ZC Aluminio Cromo | Aluminium Chrome
- ZQ Aluminio cromo mate | Aluminium matt chrome
- PQ Aluminio - cromo mate | Aluminium - matt chrome
- WQ Aluminio - blanco mate | Aluminium - matt white
- NQ Aluminio - negro mate | Aluminium - matt black
- AN Negro mate. Reflector asimétrico
Matt black. Asymmetric reflector
- AW Blanco mate. Reflector asimétrico
Matt white. Asymmetric reflector
- AP Anodizado plata mate satinado. Reflector asimétrico
Brushed silver matt anodized. Asymmetric reflector
- LN Negro mate con lamas | Matt black with louver
- LW Blanco mate con lamas | Matt white with louver
- LP Anodizado plata mate satinado con lamas
Brushed silver matt anodized with louver
- LS Níquel satinado con difusor de lamas | Brushed steel with louver
- R Rojo | Red
- N Naranja | Orange



TRIMLESS MOUNTING

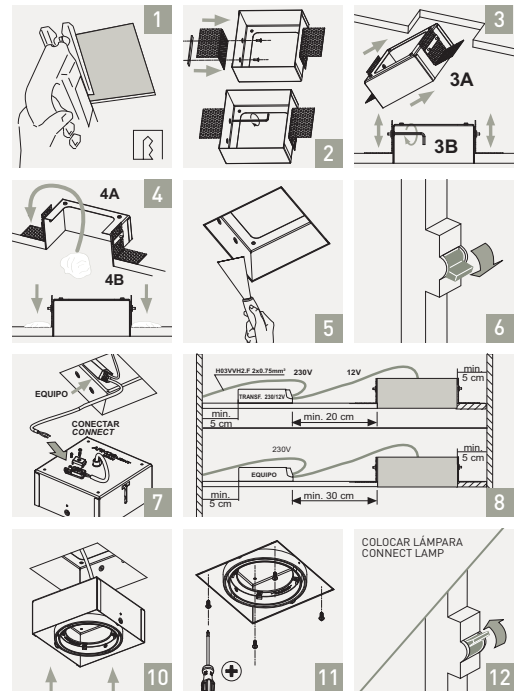

INSTALLATION SCHEMES

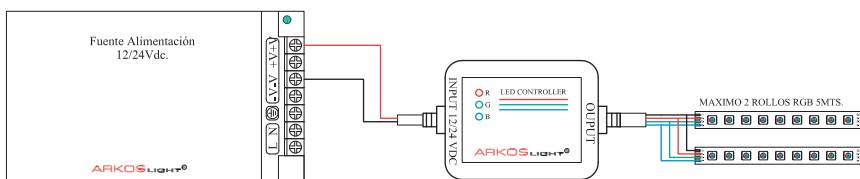

**WIRELESS RGB TOUCH CONTROLLER
WHITH POWER SUPPLY**
CONTROLADOR RGB TÁCTIL INALÁMBRICO
CON FUENTE ALIMENTACIÓN

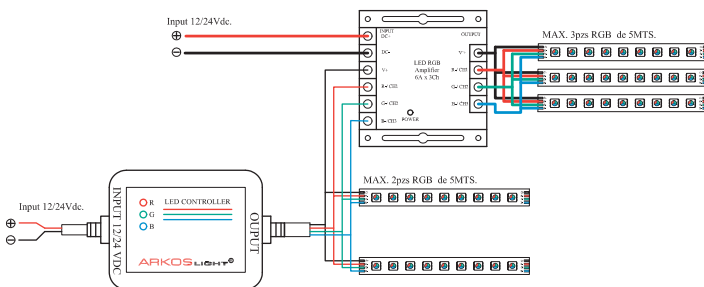

WIRELESS RGB TOUCH CONTROLLER WITH RGB LED AMPLIFIER
CONTROLADOR RGB TÁCTIL INALÁMBRICO CON AMPLIFICADOR LED RGB

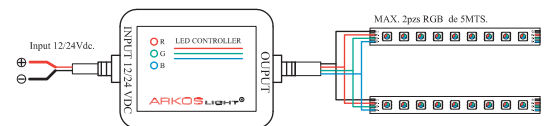



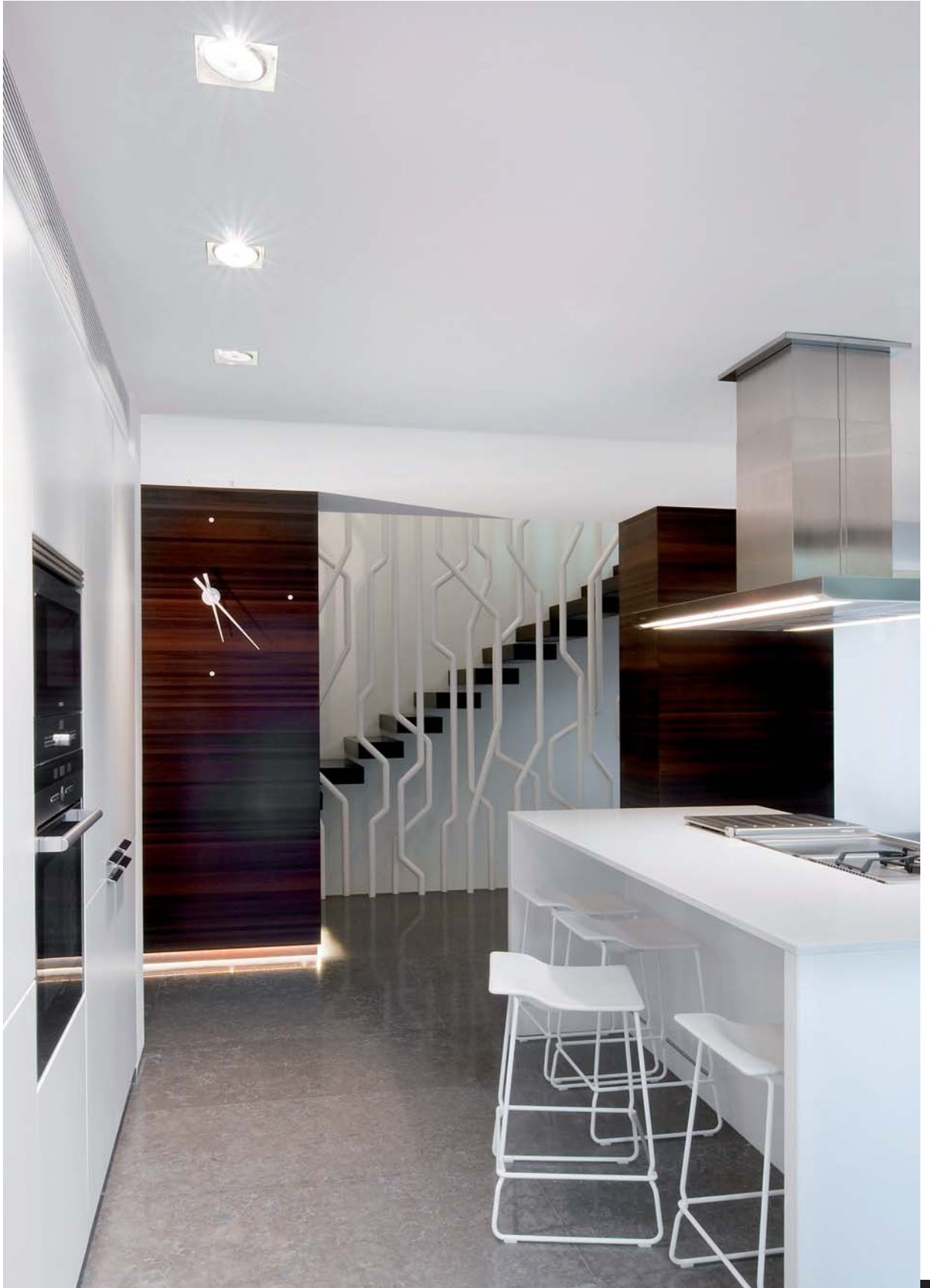









WIRELESS RGB TOUCH CONTROLLER
CONTROLADOR RGB TÁCTIL INALÁMBRICO



SYMBOLS GLOSSARY



AL	Aluminio	Aluminium	Aluminium	Alluminio	Aluminium
PC	Policarbonato	Polycarbonate	Polycarbonate	Policarbonato	Polycarbonat
PE	Polietileno	Polyethylene	Polyéthylène	Poietilene	Polyäthylen
GL	Cristal	Glass	Verre	Vetro	Glas
PPS	Polisulfona	Polysulfone	Polysulfone	Polysulfone	Polysulfon
PMMA	Polimetilmetacrilato	Polymethyl methacrylate	Polyméthacrylate de méthyle	Polimetilmetacrilato	Polymethylmetacrylat
INOX	Acero inoxidable	Stainless steel	Acier inoxydable	Acciaio inossidabile	Edelstahl
MATT	Mate	Matt	Opaque	Opaco	Matt
TRANS	Transparente	Transparent	Transparent	Trasparente	Transparent
	Fabricado en	Made of	Fabriqué en	Fabbricato in	Hergestellt aus
	Reflector	Reflector	Réflecteur	Riflettore	Reflektor
	Difusor	Diffuser	Diffuseur	Diffusore	Diffusor
	Lamas	Louver	Grille	Darklight	Raster
	Filtros para alimentación	Filters for food	Des filtres pour alimentation	Filtri per alimentazione	Filter für Nahrungsmittel
	Filtros de colores	Coloured filters	Filtres couleurs	Filtri colorati	Farbfilter
CE	Sellado CE	CE marking	Marquage CE	Per blocchi con attacco Euro	CE-gekennzeichnet
	Clase I	Class I	Classe I	Classe I	Klasse I
	Clase II	Class II	Classe II	Classe II	Klasse II
	Clase III	Class III	Classe III	Classe III	Klasse III
	Arrancador exterior	External starter	Ballast extérieur	Alimentatore esterno	Extener Starter
IPXX	Índice de protección	Protection rating	Indice de protection	Indice di protezione	Schutzkennziffer
IKXX	Índice de protección contra impactos	Impact Protection Rate	Indice de protection contre des impacts	Indicizi di protezione contro impatti	Stoßfestigkeitsgrad
	Resistente a la corrosión	Corrosion resistant	Résistant à la corrosion	Resistenza alla corrosione	Resistent gegen Korrosion
	Distancia mínima de seguridad a objetos iluminados	Minimum safety distance to illuminated objects	Distance minimale de sécurité face aux objets illuminés	Distanza minima di sicurezza ad oggetti illuminati	Mindestabstand zu dem zu beleuchtenden Objekt
	Tensión de alimentación 12V	Bulb supply voltage 12V	Tension d'alimentation de l'ampoule 12V	Tensione di alimentazione della lampada 12V	Netzspannung 12V
	Tensión de alimentación 220-240V	Bulb supply voltage 220-240V	Tension d'alimentation de l'ampoule 220-240V	Tensione di alimentazione della lampada 220-240V	Netzspannung 220-240V
MAX 100W	Potencia máxima	Maximum power	Puissance maximum	Potenza massima	Maximale Leistung
	Difusor	Diffuser	Diffuseur	Diffusore	Diffusor
	Sin discontinuidad	Seamless	Sans joint	Senza giunture	Überganglos
	Conexión con enchufe	Plug-in	Connexion avec prise	Collegamento con spina	Anschluss mit Stecker



	Transformador de seguridad	Safety transformer	Transformateur de sécurité	Trasformatore di sicurezza	Sicherheits-Vorschaltgerät mit Kurzschlussicherung
	Equipo no incluido	Equipment not included	Équipement non inclus	Alimentatore non compreso	Vorschaltgerät exklusive
	Equipo incluido	Equipment included	Équipement inclus	Alimentatore compreso	Vorschaltgerät inklusive
	Equipo electrónico incluido	Electronic equipment included	Équipement électronique inclus	Alimentatore elettronico compreso	Vorschaltgerät elektronische inklusive
	Sin ventilador, disipación pasiva	Fanless, passive dissipation	Sans ventilateur, dissipation passive	Senza ventola, dissipazione passiva	Ohne Lüfter, passive Verlustleistung
	Alojamiento en mm para empotrables	Fitting whole for recessed luminaires in mm	Espace d'emplacement en mm pour encastrables	Foro in mm ad incasso	Einbauloch in mm
	Unidades de embalaje	Packaging unit	Unités par emballage	Unità d'imballo	Verpackungseinheit
	Ángulo de basculación	Tilting angle	Angle de basculation	Angolo di inclinazione	Drehwinkel - Kippwinkel
	Doble basculación	Double tilting acción	Double basculation	Doppia inclinazione	Doppelte Schwenkbarkeit
	Ángulo de giro	Rotation angle	Angle de rotation	Angolo di rotazione	Drehwinkel
	Conexión rápida	Fast connection	Conexion rapide	Collegamento rapido	Schnellanschluss
	Equipo conexionado	Connected equipment	Équipement connecté	Alimentatore collegato	Vorschaltgerät bereits angeschlossen
	Bloque de conexión no incluido	Terminal strip not included	Bande terminale connector exclus	Morsetto non compreso	Ohne Klemmenleiste
	Válido para carril con euroadaptador	May be used on rails with EU adapter	Agréé pour chariot avec euroadaptateur	Per blocchi con attacco Euro	Einsetzbar auf Fahrbahnen mit Euroadapter
	Regulable	Dimmable	Gradable	Dimmerabile	Dimmbar
	Dispositivo para alumbrado de emergencias	Emergency lighting device	Dispositif pour éclairage de secours	Dispositivo per illuminazione di emergenza	Notbeleuchtung
	Longitud del cable	Cable length	Longueur de câble	Lunghezza di cavo	Länge des Kabels
	Regulación rápida del cable de suspensión	Quick adjustment for cable suspension	Régulation rapide du câble de suspension	Regolazione rapida del cavo di sospensione	Schnelle Regulation del Hängekabels
4000 K	Temperatura de color	Colour Temperature	Température de couleur	Temperatura di colore	Farbtemperatur
	Mando a distancia	Remote Control	Commande à distance	Telecomando	Fernbedienung
	Temperatura máxima en supeficie	Maximum surface temperature	Température maximale sur une surface	Temperatura massima in superficie	Maximale Temperatur an der Oberfläche
	Válido para techos desmontables (600x600mm)	Suitable for armstrong ceilings (600x600mm)	Valable également pour plafonds démontables (600x600mm)	Adatto a controsoffitti (600x600mm)	Geeignet für Armstrong-Decken (600x600mm)
	Luminaria con driver de marca Europea	Luminaire with EU branded driver	Luminaire avec driver de marque européenne	Apparecchio d'illuminazione con driver di marca Europea	Lichtquelle mit Driver der Marke EU
	Lámpara LED	LED lamp	Lampe LED	Lampada LED	LED-Lampe
	Opción de instalación con lámpara LED	Installation option with LED lamp	Option d'installation avec lampe LED	Opzione di installazione con lampada LED	Installationsmöglichkeit mit LED-Lampen
	Información LED actualizada	Latest LED information	Information LED actualisée	Aggiornamento informazioni sui LED	Aktualisierte LED-Information
	Tipo de instalación y dirección del haz de luz	Installation type and light beam direction	Type d'installation et direction du faisceau lumineux	Tipo d'impianto e direzione del fascio	Art und Ausrichtung des Lichtkegels
	Empotrable cuadrado para agujero redondo	Encastrable carré pour orifice rond	Quadrato da incasso per foro rotondo	Regolazione rapida del cavo di sospensione	Einbaubares Quadrat für runde Öffnung
	Categoría anti-deslumbramiento	Anti-glare category	Catégorie anti-éblouissement	Categoria anti abbagliamento	Kategorie Anti-Blendung
	Válido para exterior	May be used outdoors	Agréé pour l'extérieur	Adatto per uso esterno	Außen einsetzbar.
	Para uso interior	For indoor use	Pour usage en intérieur	Per uso interno	Zur Benutzung in Innenräumen

INFO UPDATE

Arkoslight se compromete a ofrecer siempre las luminarias tecnológicamente más avanzadas. Por ello, renovamos nuestros productos constantemente para que estén dotados en todo momento de la tecnología LED más moderna del mercado, con la máxima eficiencia y las mejores prestaciones. Consciente de la velocidad a la que evoluciona el LED, Arkoslight pone a su disposición el siguiente listado de códigos QR, a través de los cuales se puede acceder a la versión de las páginas de este catálogo con la información técnica más reciente de todos los productos con fuente de luz LED.

Arkoslight is committed to always offering the most technologically advanced luminaires. With that in mind,

we are constantly renewing our products to ensure they are fitted with the most modern LED technology available in the market at any given time, with the highest levels of efficiency and the best features. Acutely aware of how fast LED technology is evolving, Arkoslight has created the following QR codes. By using these codes, you can access the very latest and most up-to-date technical information in this catalogue on all products with an LED light source.

Arkoslight s'engage à toujours offrir les luminaires les plus avancés technologiquement. Pour ce faire, nous renouvelons en permanence nos produits pour qu'ils soient toujours équipés de la technologie LED la plus moderne du marché, en apportant l'efficacité maximale et les meilleures



AURAE



EYE



HIDDEN



LEX ECO



BATH



FORTY



LARK



MADISON



DOT



GAP



LARK-111 & LARK-111 | 12V



MEC



DROP



GIRO



LED WALL LIGHTS



MIX

prestations. Conscient de la vitesse à laquelle évoluent la technologie LED, Arkoslight met à votre disposition la liste des codes QR qui suit, elle vous permettra d'accéder à la version des pages de ce catalogue sur lesquelles vous trouverez toutes les informations techniques à jour sur l'ensemble des produits utilisant la source LED.

Arkoslight si impegna ad offrire sempre l'illuminazione tecnologicamente più avanzata. Pertanto, rinnoviamo costantemente i nostri prodotti, dotati sempre della più moderna tecnologia LED sul mercato, con elevata efficienza e buone prestazioni. Consapevoli della velocità con cui si evolve LED, Arkoslight offre il seguente elenco di codici QR, attraverso cui è possibile accedere alla versione

delle pagine di questo catalogo con le ultime informazioni tecniche su tutti i prodotti con sorgente luminosa a LED.

Arkoslight bietet Ihnen stets technologisch fortgeschrittenste Lichtquellen an. Aus diesem Grund erneuern wir unsere Produkte fortwährend, sodass diese in jedem Moment mit der modernsten LED-Technologie maximaler Effizienz und dem besten Leistungsvermögen auf dem Markt ausgerüstet sind. Arkoslight ist sich der Entwicklungsgeschwindigkeit von LEDs bewusst und stellt die folgende Auflistung von QR-Codes zur Verfügung. Über diese haben Sie Zugang zu den Seiten dieses Kataloges mit den neuesten technischen Informationen aller Produkte mit LED-Lichtquelle.



OFFICE



SLIM



TWIST



ORBITAL MINI



SLIMGOT



WIN



QUAD



STAR



ZEN



SKY



STRAM



REFERENCE INDEX

A010-01-XX-	172, 182, 337	A071-XX-01-	040	A186-XX-01-	136	A203-22-XX-	264
A010-02-XX-	176, 183, 339	A071-XX-02-	040	A187-01-XX-	028	A204-11-XX-	152
A010-03-XX-	180, 186, 342	A071-XX-03-	040	A187-02-XX-	028	A204-12-XX-	152
A010-04-XX-	181, 187, 343	A071-XX-04-	040	A187-03-XX-	028	A204-21-XX-	157
A010-11-XX-	172, 182	A071-XX-05-	040	A187-04-XX-	028	A204-22-XX-	157
A010-12-XX-	176, 183	A071-XX-06-	040	A187-11-XX-	028	A205-11-XX-	268
A010-13-XX-	180, 186	A071-XX-07-	040	A187-12-XX-	028	A205-21-XX-	268
A010-14-XX-	181, 187	A071-XX-08-	040	A187-12-XX-	028	A205-22-XX-	268
A011-11-XX-	337	A071-XX-09-	040	A187-13-XX-	028	A205-31-XX-	268
A011-12-XX-	337	A071-XX-10-	040	A187-14-XX-	028	A205-32-XX-	268
A011-13-XX-	337	A071-XX-11-	040	A188-01-XX-	032	A206-01-XX-	268
A011-21-XX-	339	A071-XX-12-	040	A188-02-XX-	032	A206-02-XX-	268
A011-22-XX-	339	A071-XX-13-	040	A188-11-XX-	032	A206-11-XX-	268
A011-23-XX-	339	A071-XX-14-	040	A188-12-XX-	032	A206-12-XX-	268
A011-31-XX-	342	A071-XX-15-	040	A189-01-XX-	042	A206-21-XX-	268
A011-32-XX-	342	A071-XX-16-	040	A189-02-XX-	042	A206-22-XX-	268
A011-33-XX-	342	A111-00-11-	088	A189-03-XX-	042	A207-11-XX-	269
A011-41-XX-	343	A111-01-XX-	088	A189-11-XX-	046	A207-21-XX-	269
A011-42-XX-	343	A111-02-XX-	088	A189-12-XX-	046	A207-22-XX-	269
A011-43-XX-	343	A113-00-11-	090	A189-13-XX-	046	A207-31-XX-	269
A020-01-XX-	160, 166	A113-01-XX-	090	A190-01-XX-	048	A207-32-XX-	269
A020-02-XX-	162, 167	A113-02-XX-	090	A190-02-XX-	048	A208-01-XX-	269
A020-03-XX-	164, 170	A114-00-11-	091	A190-03-XX-	048	A208-02-XX-	269
A020-04-XX-	165, 171	A114-01-XX-	091	A192-01-01-	404	A208-11-XX-	269
A020-11-XX-	160, 166	A114-02-XX-	091	A192-02-XX-	404	A208-12-XX-	269
A020-12-XX-	162, 167	A131-00-11-	106	A193-01-XX-	022	A208-21-XX-	269
A020-13-XX-	164, 170	A131-01-XX-	106	A193-02-XX-	022	A208-22-XX-	269
A020-14-XX-	165, 171	A131-02-XX-	106	A193-03-XX-	022	A209-00-XX-	269
A030-01-XX-	410	A133-00-11-	107	A193-04-XX-	022	A209-01-XX-	269
A030-02-XX-	410	A133-01-XX-	107	A194-01-XX-	026	A209-02-XX-	269
A030-03-XX-	413	A133-02-XX-	107	A194-02-XX-	026	A209-03-00-	269
A030-04-XX-	413	A151-00-11-	100	A195-02-XX-	332	A210-00-XX-	114
A040-01-XX-	408	A151-01-XX-	100	A195-03-XX-	332	A211-00-XX-	142
A040-02-XX-	408	A151-02-XX-	100	A195-04-XX-	332	0000-55-XX-	225, 236, 238
A040-03-XX-	408	A153-00-11-	101	A195-05-XX-	332	0014-00-00-	116
A061-XX-11-	084	A153-01-XX-	101	A196-11-00-	190	0017-00-00-	116
A061-02-XX-	084	A153-02-XX-	101	A196-12-00-	190	0029-00-00-	100
A067-00-11-	084	A155-00-11-	110	A196-13-00-	190	0030-00-00-	100
A063-00-11-	086	A155-01-XX-	110	A196-21-00-	192	0031-00-XX-	104
A063-01-XX-	086	A155-02-XX-	110	A196-22-00-	192	0037-01-01-	130
A063-02-XX-	086	A157-00-11-	113	A196-23-00-	192	0038-01-01-	130
A065-00-11-	087	A157-01-XX-	113	A196-31-00-	194	0120-00-00-	116
A065-01-XX-	087	A157-02-XX-	113	A196-32-00-	194	0202-00-00-	116
A065-02-XX-	087	A171-00-11-	092	A196-33-00-	194	0300-00-00-	088
A067-01-XX-	084	A171-01-XX-	092	A197-01-XX-	018	0301-00-00-	090
A067-02-XX-	084	A171-02-XX-	092	A197-02-XX-	018	0302-00-00-	088
A070-XX-01-	034, 035	A173-00-11-	098	A197-03-XX-	018	0303-00-00-	131
A070-XX-02-	034, 035	A173-01-XX-	098	A197-04-XX-	018	0304-00-00-	131
A070-XX-03-	034, 035	A173-02-XX-	098	A198-01-XX-	020	0307-00-00-	131
A070-XX-04-	034, 035	A181-01-01-	098	A198-02-XX-	020	0308-00-00-	131
A070-XX-05-	034, 035	A182-01-01-	098	A198-03-XX-	020	0313-00-00-	101
A070-XX-06-	034, 035	A183-01-XX-	224	A198-04-XX-	020	0314-00-00-	101
A070-XX-07-	034, 035	A183-02-XX-	224	A200-11-XX-	208	0321-01-01-	134
A070-XX-08-	034, 035	A183-03-XX-	224	A200-21-XX-	208	0325-01-01-	134
A070-XX-09-	034, 035	A184-11-XX-	344	A200-22-XX-	208	0331-00-00-	090
A070-XX-10-	034, 035	A184-12-XX-	344	A201-00-XX-	213	0332-00-00-	091
A070-XX-11-	034, 035	A184-13-XX-	344	A202-11-XX-	453	0333-00-00-	091
A070-XX-12-	034, 035	A184-21-XX-	238	A202-22-XX-	453	0337-01-01-	130
A070-XX-13-	034, 035	A184-22-XX-	238	A202-23-XX-	453	0338-01-01-	130
A070-XX-14-	034, 035	A184-23-XX-	238	A203-11-XX-	264	0341-00-00-	126
A070-XX-15-	034, 035	A185-01-XX-	236	A203-12-XX-	264	0342-00-00-	127
A070-XX-16-	034, 035	A185-02-XX-	236	A203-21-XX-	264	0343-00-00-	126

0344-00-00	127	0476-XX-00	462	2503-01-10-	377	2601-00-XX-	318
0345-00-00	118	0477-18-XX	454	2503-02-10-	378	2601-05-XX-	324
0346-00-00	120	0477-26-XX	454	2503-12-10-	377	2601-20-XX-	318
0347-00-00	125	0477-32-XX	454	2503-14-05-	378	2601-25-XX-	324
0350-00-00	110	0477-42-XX	454	2504-12-XX-	363	2601-46-01-	418
0351-00-00	113	0479-07-XX	454	2504-60-XX-	362, 416	2601-47-XX-	421
0354-00-00	092	0486-XX-00	459	2504-90-XX-	362	2601-48-02-	429
0355-00-00	092	0486-XX-35	459	2505-12-XX-	370	2601-49-XX-	433
0401-XX-12	459	0486-XX-70	459	2505-60-XX-	366	2602-00-00-	214
0412-50-XX	454	0495-14-XX	455	2505-90-22-	366	2602-10-00-	219
0414-XX-00	454	0495-21-XX	455	2506-60-XX-	360, 414	2602-91-00-	219
0415-50-XX	455	0495-28-XX	455	2526-XX-00-	381	2602-92-00-	219
0417-10-XX	454	0495-35-XX	455	2534-00-00-	348	3508-00-00-	068
0417-13-XX	454	0502-XX-00-	423	2534-70-00-	240	3510-XX-00-	068
0417-18-XX	454	0700-01-XX-	219	2536-00-00-	349	3511-XX-00-	068
0417-26-XX	454	0700-02-XX-	246, 351	2536-70-00-	244	3512-00-00-	068
0418-00-00	456	0700-03-XX-	249, 353, 357	2537-00-XX-	351	3513-XX-00-	068
0419-00-00	456	0700-04-XX-	074	2537-70-XX-	246	3519-00-00-	072
0421-15-00-F	455	0700-05-XX-	064	2538-01-XX-	351	3520-00-00-	072
0428-70-00-C	455	0700-07-XX-	208, 213, 225	2538-02-XX-	351	3521-00-00-	072
0429-70-00-F	455		236, 239, 344	2538-71-XX-	246	3531-00-00-	074
0430-15-00-C	455	0702-01-XX-	208, 225	2538-72-XX-	246	3532-00-00-	074
0432-00-XX	459, 462		239, 344	2539-00-XX-	349	3533-00-00-	075
0433-00-XX	452, 458, 459	0826-00-00-	383, 391	2539-70-XX-	244	3534-00-00-	075
0434-00-XX	452, 453, 459	0827-00-00-	386, 393	2542-71-XX-	248	3535-00-00-	075
	461, 463	0830-00-00-	069	2542-91-XX-	352, 355	3536-00-00-	075
0436-70-XX	455	0831-XX-00-	069	2562-01-XX-	353	3537-00-00-	075
0436-15-XX	455	0832-00-00-	072	2562-71-XX-	249, 252	3539-00-00-	068
0437-20-XX	456	0836-XX-00-	093	2562-91-XX-	355, 357	4025-00-XX-	077
0437-35-XX	456	0844-00-00-	358	2563-01-XX-	376	4041-00-XX-	080
0437-70-XX	456	0900-50-00-	394	2563-11-00-	376	4043-00-XX-	080
0440-XX-00	456	0900-00-XX-	434	2582-01-XX-	353	4081-00-XX-	066
0444-00-XX	454	2301-01-00-	196	2582-02-XX-	353	4083-00-XX-	066
0448-00-00	456	2301-02-00-	199	2582-XX-90-	357	4089-00-XX-	066
0449-50-XX	454	2301-03-00-	200	2582-71-XX-	249	4096-00-XX-	058
0449-10-XX	454	2301-04-00-	201	2582-72-XX-	249	4097-00-XX-	058, 063
0450-30-XX	454	2301-11-00-	202	2591-00-XX-	274	4098-00-XX-	058
0450-45-XX	454	2301-12-00-	205	2591-02-XX-	274	4099-00-XX-	058, 063
0450-60-XX	454	2301-13-00-	207	2591-05-XX-	274	4099-01-XX-	058, 063
0451-50-XX	454	2301-14-00-	207	2591-07-21-	274	4099-07-XX-	058, 063
0451-75-XX	454	2302-01-00-	196	2591-21-XX-	279	4100-00-00-	064
0458-00-00	456	2302-02-00-	199	2591-28-XX-	279	4101-00-00-	064
0463-75-XX	454	2302-03-12-	200	2594-00-XX-	283	4141-00-XX-	082
0463-10-XX	454	2302-11-00-	202	2594-02-XX-	283	4143-00-XX-	082
0465-35-00-XX	456	2302-12-00-	205	2594-05-XX-	292	4144-00-00-	082
0465-70-00-XX	456	2303-02-XX-	148	2594-07-XX-	292	4145-00-00-	082
0465-70-42-XX	456	2303-04-24-	146	2594-20-XX-	290	4220-00-XX-	050
0467-24-XX	455	2305-XX-00-	382, 383	2594-22-XX-	290	4221-00-XX-	050
0467-39-XX	455		386, 393	2594-25-XX-	287	4230-00-XX-	056
0467-54-XX	455	2305-XX-10-	382, 386	2594-27-XX-	287	4231-00-XX-	056
0467-55-XX	455		392, 393	2594-42-39-	300	4232-00-XX-	056
0467-80-XX	455	2305-41-XX-	382	2594-43-XX-	305	4450-00-00-	158
0467-90-XX	455	2305-42-05-	383	2594-44-XX-	305	4452-00-00-	158
0468-20-30	455	2306-72-00-	391	2594-47-39-	309	4597 R0-XX-	078
0468-35-XX	455	2306-42-05-	391	2594-50-XX-	300	4599 R0-XX-	078
0434-00-XX	455	2307-01-XX-	382	2594-52-XX-	300	5514-00-00-	423
0468-70-XX	455	2307-02-XX-	383	2594-55-XX-	309, 311	5515-00-00-	423
0469-15-42	455	2307-72-35-	391	2594-57-54-	309	5800-45-XX-	438
0469-35-XX	455	2500-71-XX-	256, 257	2594-96-XX-	313	5800-60-XX-	438
0469-70-42	455	2502-01-10-	352	2594-97-XX-	295	5810-XX-00-	445
0474-00-XX	456	2502-71-10-	248	2594-98-XX-	312, 313, 315		
0475-XX-31	455	2502-91-90-	355	2594-99-XX-	294, 295, 313		

Special Thanks

Mr. Gavan Divola | SONIC LIGHTING | Victoria (Australia)
Mr. Anton Van't Noordende | N'LIGHT | Helmond (Holland)
Mr. Hisham Habib | ELECTRA EGYPT | Giza (Egypt)
M. Jean Luc Bachacou | BEAR SARL | Canejan (France)
Sig. Riccardo di Pascalis | Cervo rappresentanza | Milano (Italia)
Mr. Nikolaos Kafkas and Mr. Konstantinos Kafkas | V. KAFKAS SA | Peania – Athens (Greece)
Arch. Michela Viola | MINI STUDIO | Pavia (Italia)
Manuel Dutor Santoja | Valencia
CENTENO Y MESSIAS, SC | Málaga
David de la Fuente | www.azularquitectura.com
Claudio Parte Arroyo | Merclahec

Vicente Navarro | Estudio de Interiorismo
Vicente Vidal | Estudio de Interiorismo
Adriana F. López – Barajas | Estudio de Interiorismo
Interiorista Sebastián Ruiz Maldonado
Moncly Estudio de Interiorismo
Francisco Guijarro – Stucco Llums
F&S automóviles
Juan Ignacio Jara – Llara Invest
Restaurante Vertical
Restaurante Lienzo
Gil de Los Rios

Photography

Mariela Apollonio | www.fotografadearquitectura.com
Yann Delanaux Photographe Professionel | www.yandelanaux.com
Mariajosé Fraga | Imago Fotografía | www.imagofoto.es
David Frutos | Bisimages | www.bisimages.com
Alfred García Gotós – Estudi | www.alfredgarciafotos.com
Platty García Photography | www.plattygarcia.blogspot.com.es
Jesús Granada. Fotógrafo | www.jesusgranada.com
Jónathan Martín Fotógrafo | www.jonathanmartin.es
Remigi Miguel Fotógrafo
Joao Morgado – Fotografía de Arquitectura | www.photo.joamorgado.com
Nudo estudio | www.nudoestudio3d.com
Diego Opazo | www.diegoopazo.com
Paul Ott Graz | www.paul-ott.at/aktuell.php
Hector Rubio Fotógrafo | www.images-positive.com
Héctor Santos – Díez | Bisimages | www.bisimages.com
James Silverman | www.jamessilverman.co.uk
3D Visual Effects | Infografía | www.3ve.es

Graphic Design

Estudio David Cercós

Print

Mari Montañana

ARKOS LIGHT S.L.

Calle N · Pol. Ind. EL OLIVERAL
46394 Ribarroja del Turia · Valencia (Spain)
Tel. +34 961 667 207 · Fax +34 961 667 054
info@arkoslight.com · www.arkoslight.com



